

Product Data

4WCZ6036A through 4WCZ6060A
Single Package Convertible Heat Pump
16 SEER
3, 4 & 5 Ton
R-410A

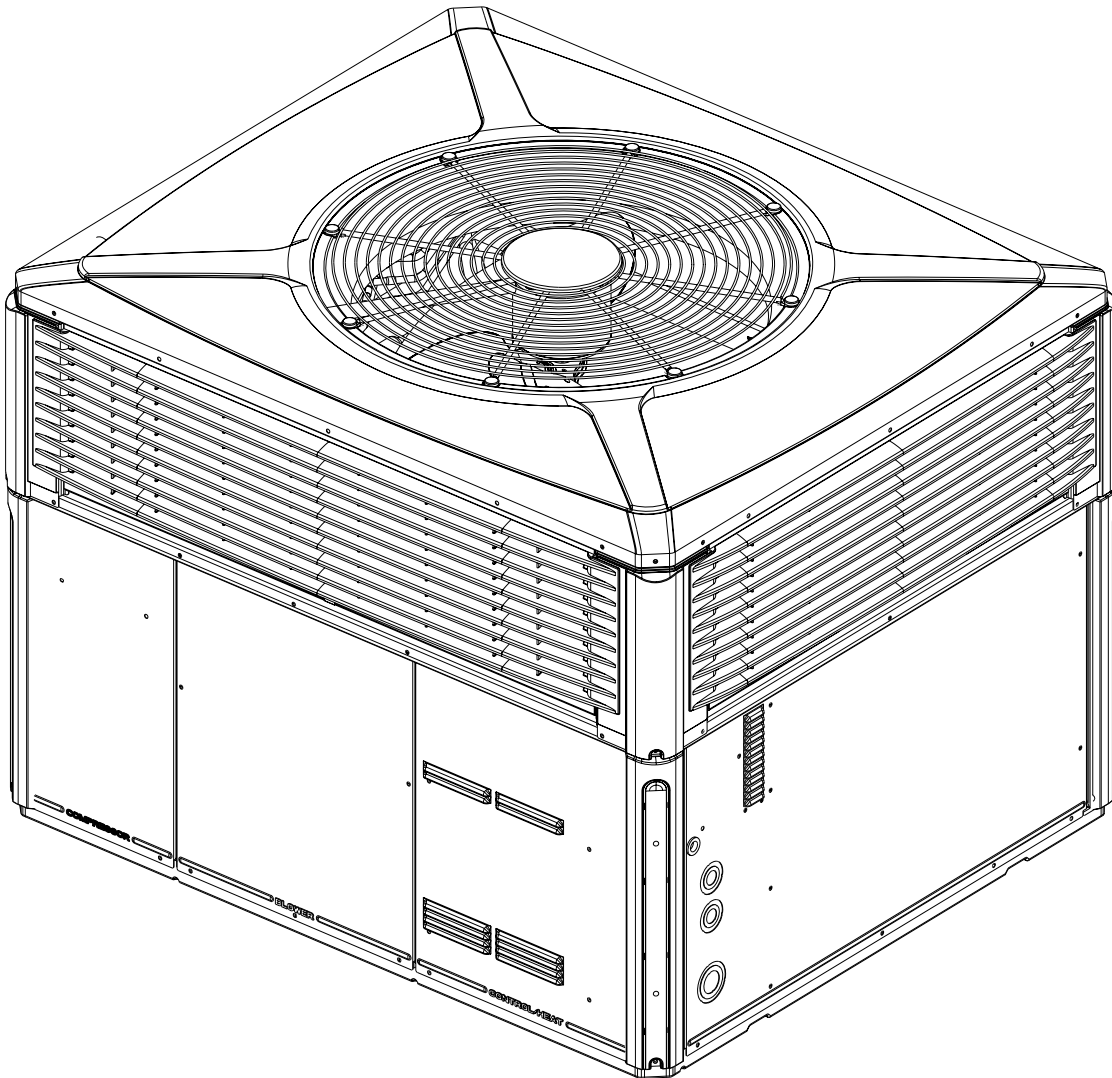

It's Hard to Stop a Trane.

Single Packaged Electric Heat Pump System

Trane offers a complete family of electric heat pump heating and cooling systems, designed to keep you comfortable all year long, regardless of the weather, while keeping your operating costs as low as possible. A heat pump operates efficiently as both an air conditioner and a heater. In the summer, the heat pump cools your home just like any other air conditioner by pulling the heat from the inside and releasing it outdoors. In the winter, it captures the heat that is always present in the outdoor air and transfers it indoors.

Introducing the new TRANE Single Packaged Electric Heat Pump System.

Single Packaged Electric Heat Pump Systems are easy and versatile to install. Because cooling and heating functions are all contained in a single cabinet, a Trane packaged heat pump system is easy to install and service. It can be flush mounted beside your home at ground level or placed on the roof for horizontal or downflow installation. When connected to an optional Trane thermostat control and air distribution ducts, you have a highly efficient, total home comfort system.

Single Packaged Electric Heat Pump Systems are unmatched in quality and reliability. All major components on these products, including the compressor, have been designed and manufactured for maximum service. Every Climatuff® compressor is designed and manufactured to exacting specifications. Each design is life tested in extreme environments to ensure reliable and long lasting operation in normal applications. Each compressor has internal motor protection for added reliability.

Contents

Optional Equipment Listing	4
<hr/>	
General Data	5
<hr/>	
Heater Data	8
<hr/>	
SPEK Data	9
<hr/>	
Performance Data	
Cooling	12
Heating	14
Indoor Blower	16
<hr/>	
Typical Wiring	18
<hr/>	
Optional Equipment	20
<hr/>	
Dimensional Data	25
<hr/>	
Mechanical Specifications	31
<hr/>	

Optional Equipment

OPTIONAL EQUIPMENT FOR PACKAGED UNITS (check mark [✓] indicates accessories included)

Hinged Filter Access Door (4WCZ6036).....	BAYACCDOR1A[]
Hinged Filter Access Door (4WCZ6048-060).....	BAYACCDOR2A[]
Roof Curb Full Perimeter (4WCZ6036A) ③.....	BAYCURB050A[]
Roof Curb Full Perimeter (4WCZ6048-060A) ③.....	BAYCURB051A[]
Roof Curb Utility Extension Kit (BAYCURB050A).....	BAYUTIL101B[]
Roof Curb Utility Extension Kit (BAYCURB051A).....	BAYUTIL102B[]
0-25% Motorized Outside Air Damper (4WCZ6036).....	BAYDMPR101A[]
0-25% Motorized Outside Air Damper (4WCZ6048-060).....	BAYDMPR102A[]
Outside Air Control for V.S. Economizer (4WCZ6036A).....	BAYOSAC001A[]
Outside Air Control for V.S. Economizer (4WCZ6048-060).....	BAYOSAC002A[]
0-25% Manual Fresh Air Damper (4WCZ6036A) ①.....	BAYOSAH001A[]
0-25% Manual Fresh Air Damper (4WCZ6048-060A) ①.....	BAYOSAH002A[]
16" Round Duct Adapter (2 per box) (4WCZ6036A) ⑥.....	BAYSQRD001A[]
18" Round Duct Adapter (2 per box) (4WCZ6024-060A) ⑥.....	BAYSQRD002A[]
0-100% Mod Economizer w/Baro. Relief (4WCZ6036A) ①②④.....	BAYECON103A[]
0-100% Mod. Economizer w/Baro. Relief (4WCZ6048-060A) ①②④.....	BAYECON104A[]
0-100% Horizontal Economizer (4WCZ6036A) ①②.....	BAYECON203A[]
0-100% Horizontal Economizer (4WCZ6048-060A) ①②.....	BAYECON204A[]
Economizer Relay Kit (required for Heat Pump applications).....	BAYRLAY006A[]
Enthalpy Control for Economizer (solid state).....	BAYENTH001A[]
Remote Potentiometer (All-BAYECON***A).....	BAYSTAT023[]
1"-2" Filter Frame (4WCZ6036A) (20 x 25 filter not included) ①.....	BAYFLTR101A[]
1"-2" Filter Frame (4WCZ6048-060A) (20 x 20,20X18 filter not included) ①.....	BAYFLTR201A[]
Evaporator Defrost Control (Low Ambient Cooling) Kit ⑤.....	BAYLOAM011A[]
Head Pressure Control (Low Ambient Cool) (208/240v) Kit ⑤.....	BAYLOAM105A[]
Crankcase Heater Scroll (4WCZ6036,048A1/3,060A1/3)(230v) ⑤.....	BAYCCHT102A[]
Crankcase Heater Scroll (4WCZ6036-060A3)(460v) ⑤.....	BAYCCHT404B[]
Adapter Curb 4WCZ6036A to BAYCURB030,38.....	BAYADAP050A[]
Adapter Curb 4WCZ6036A to BAYCURB033.....	BAYADAP051A[]
Adapter Curb 4WCZ6048-060A to BAYCURB030,38.....	BAYADAP052A[]
Adapter Curb 4WCZ6048-060A to BAYCURB033.....	BAYADAP053A[]
Adapter Curb 4WCZ6048-060A to BAYCURB034.....	BAYADAP054A[]
12" Duct Shroud Covers Horizontal 4WCZ6036-060A ⑦.....	BAYCOVR112A[]
18" Duct Shroud Covers Horizontal 4WCZ6036-060A ⑦.....	BAYCOVR118A[]
Extreme Condition Mounting Kit - All BAYCURB & BAYADAP.....	BAYEXMK001A[]
Extreme Condition Mounting Kit - All BAYUTIL.....	BAYEXMK002A[]
Extreme Condition Mounting Kit - All Slab Mounts.....	BAYEXMK003A[]
Lifting Lug Kit BAYLIFT002B[]	
SUPPLEMENTARY HEATERS (1 PHASE)	
3.76/5.00 KW Heater (208/240V 1PH) (4WCZ6036-060A1).....	BAYHTRV105E[]
6.00/8.00 KW Heater (208/240V 1PH) (4WCZ6036-060A1).....	BAYHTRV108E[]
7.50/10.00 KW Heater (208/240V 1PH) (4WCZ6036-0601).....	BAYHTRV110E[]
11.27/15.00 KW Heater (208/240V 1PH) (4WCZ6036-060A1).....	BAYHTRV115E[]
15.00/20.00 KW Heater (208/240V 1PH) (4WCZ6048-060A1).....	BAYHTRV120E[]
18.78/25.00 KW Heater (208/240V 1PH) (4WCZ6048-060A1).....	BAYHTRV125E[]
SUPPLEMENTARY HEATERS (3 PHASE)	
3.76/5.00 KW Heater (208/240V 3PH) (4WCZ6036-060A3).....	BAYHTRV305E[]
6.00/8.00 KW Heater (208/240V 3PH) (4WCZ6036-060A3).....	BAYHTRV308E[]
7.50/10.00 KW Heater (208/240V 3PH) (4WCZ6036-060A3).....	BAYHTRV310E[]
11.27/15.00 KW Heater (208/240V 3PH) (4WCZ6036-060A3).....	BAYHTRV315E[]
15.00/20.00 KW Heater (208/240V 3PH) (4WCZ6048-060A3).....	BAYHTRV320E[]
18.78/25.00 KW Heater (208/240V 3PH) (4WCZ6048-060A3).....	BAYHTRV325E[]
5.00 KW Heater (460V 3PH) (4WCZ6036-060A4).....	BAYHTRV405E[]
8.00 KW Heater (460V 3PH) (4WCZ6036-060A4).....	BAYHTRV408E[]
10.00 KW Heater (460V 3PH) (4WCZ6036-060A4).....	BAYHTRV410E[]
10.00 KW Heater (460V 3PH) (4WCZ6036-060A4).....	BAYHTRV415E[]
10.00 KW Heater (460V 3PH) (4WCZ6048-060A4).....	BAYHTRV420E[]
15.00 KW Heater (460V 3PH) (4WCZ6048-060A4).....	BAYHTRV425E[]
Single Power Entry Kit ⑧.....	BAYSPEK060E[]
Single Power Entry Kit ⑧.....	BAYSPEK061E[]
Single Power Entry Kit ⑧.....	BAYSPEK062E[]
Single Power Entry Kit ⑧.....	BAYSPEK063E[]
Single Power Entry Kit ⑧.....	BAYSPEK064E[]
Single Power Entry Kit ⑧.....	BAYSPEK065E[]

- NOTES: ① Must use internal filter frame when economizer or fresh air kit is used.
 ② Dry bulb control standard with economizer.
 ③ Ships knocked down.
 ④ Downflow only.
 ⑤ Low Ambient cooling requires crankcase heater (BAYCCHT----A).
 ⑥ It is the responsibility of the installing dealer to properly size the ductwork for each specific application.
 ⑦ BAYCOVR112,118A will not cover BAYSQRD002A applications.
 ⑧ See tables on pages 8 - 11 for matching kit with units and heaters.

General Data

MODEL	4WCZ6036A1000A	4WCZ6036A3000A	4WCZ6036A4000A
RATED Volts/Ph/Hz	208-230/1/60	208-230/3/60	460/3/60
Performance Cooling			
BTUH (High)	36000	36000	36000
Indoor Airflow (CFM)	1125	1125	1125
Power Input (KW)	2.61	2.61	2.61
BTUH (Low)	25200	25200	25200
Indoor Airflow (CFM)	825	825	825
Power Input (KW)	1.8	1.8	1.8
EER - HI / LOW / SEER	12.2 / 13.3 / 16.4	12.2 / 13.3 / 16.4	12.2 / 13.3 / 16.4
Sound Power Rating [dB(A)] ^②	70	70	70
Performance Heating^①			
(High Temp.)BTUH / COP (High)	34000 / 3.9	34000 / 3.9	34000 / 3.9
Power Input (KW)	2.59	2.59	2.59
(Low Temp.) BTUH / COP (High)	20800 / 2.62	20800 / 2.62	20800 / 2.62
Power Input (KW)	2.371	2.371	2.371
(High Temp.)BTUH / COP (Low)	23400 / 3.9	23400 / 3.9	23400 / 3.9
Power Input (KW)	1.8	1.8	1.8
(Low Temp.) BTUH / COP (Low)	13300 / 2.2	13300 / 2.2	13300 / 2.2
Power Input (KW)	1.78	1.78	1.78
HSPF (BTU / Watt-Hr.) ^⑥	9	9	9
POWER CONN.—V/Ph/Hz	208-230/1/60	208-230/3/60	460/3/60
Min. Brch. Cir. Ampacity ^③	26.2	19.1	10.4
Fuse Size — Max. / Recmd. (amps)	40 / 40	30 / 30	15 / 15
COMPRESSOR	2-STAGE SCROLL	2-STAGE SCROLL	2-STAGE SCROLL
Volts/Ph/Hz	208-230/1/60	208-230/3/60	460/3/60
R.L. Amps — L.R. Amps	16.7 / 82	11.2 / 58	4.5 / 29
OUTDOOR COIL — TYPE	SPINE-FIN	SPINE-FIN	SPINE-FIN
Rows/F.P.I.	2 / 24	2 / 24	2 / 24
Face Area (sq.ft.)	15.49	15.49	15.49
Tube Size (in.)	3/8	3/8	3/8
Refrigerant Control	EXPANSION VALVE	EXPANSION VALVE	EXPANSION VALVE
INDOOR COIL — TYPE	PLATE FIN	PLATE FIN	PLATE FIN
Rows/F.P.I.	4 / 15	4 / 15	4 / 15
Face Area (sq.ft.)	3.54	3.54	3.54
Tube Size (in.)	3/8	3/8	3/8
Refrigerant Control	EXPANSION VALVE	EXPANSION VALVE	EXPANSION VALVE
Drain Conn. Size (in.)	3/4 FEMALE NPT	3/4 FEMALE NPT	3/4 FEMALE NPT
OUTDOOR FAN — TYPE	PROPELLER	PROPELLER	PROPELLER
Dia. (in.)	23.4	23.4	23.4
Drive/No. Speeds	DIRECT / 1	DIRECT / 1	DIRECT / 1
CFM @ 0.0 in. w.g. ^④	3000	3000	3000
Motor — HP/R.P.M.	1/6 / 830	1/6 / 830	1/6 / 830
Volts/Ph/Hz	208-230/1/60	208-230/1/60	460/1/60
F.L. Amps/L.R. Amps	0.9 / 1.65	0.9 / 1.65	0.5 / 0.84
INDOOR FAN — TYPE	CENTRIFUGAL	CENTRIFUGAL	CENTRIFUGAL
Dia x Width (in.)	10 X 10	10 X 10	10 X 10
Drive/No. Speeds	DIRECT / VARIABLE	DIRECT / VARIABLE	DIRECT / VARIABLE
CFM @ 0.0 in. w.g. ^⑤	SEE FAN PERFORMANCE TABLE	SEE FAN PERFORMANCE TABLE	SEE FAN PERFORMANCE TABLE
Motor — HP/R.P.M.	1/2 / VARIABLE	1/2 / VARIABLE	1/2 / VARIABLE
Volts/Ph/Hz	208-230/1/60	208-230/1/60	208-230/1/60
F.L. Amps/L.R. Amps	4.3 / 4.3	4.3 / 4.3	4.3 / 4.3
FILTER / FURNISHED	NO	NO	NO
Type Recommended	THROWAWAY	THROWAWAY	THROWAWAY
Recmd. Face Area (sq. ft.) ^⑦	4.0	4.0	4.0
REFRIGERANT / Charge (lbs.)	R410A / 7.8	R410A / 7.8	R410A / 7.8
DIMENSIONS	H X W X L	H X W X L	H X W X L
Crated (in.)	47.86 / 44.5 / 52.03	47.86 / 44.5 / 52.03	47.86 / 44.5 / 52.03
WEIGHT / Shipping / Net (lbs.)	468 / 372	468 / 372	468 / 372

① Certified in accordance with the Unitary Air-Conditioner Equipment certification program, which is based on ARI Standard 210/240.

② Sound Power values are not adjusted for ARI 270-95 tonal corrections.

③ Calculated in accordance with currently prevailing Nat'l Electrical Code.

④ Standard Air — Dry Coil — Outdoor.

⑤ Standard Air — Wet Coil — Indoor.

⑥ Rated in accordance with D.O.E. test procedure.

⑦ Filters must be installed in return air system. Square footages listed are based on 300 f.p.m. face velocity. If permanent filters are used size per manufacturer's recommendations with clean resistance of 0.05" W.C.

General Data

MODEL	4WCZ6048A1000A	4WCZ6048A3000A	4WCZ6048A4000A
RATED Volts/Ph/Hz	208-230/1/60	208-230/3/60	460/3/60
Performance Cooling			
BTUH (High)	47500	47500	47500
Indoor Airflow (CFM)	1575	1575	1575
Power Input (KW)	3.26	3.26	3.26
BTUH (Low)	34500	34500	34500
Indoor Airflow (CFM)	1150	1150	1150
Power Input (KW)	2.58	2.58	2.58
EER - HI / LOW / SEER	12.0 / 13.6 / 16.0	12.0 / 13.6 / 16.0	12.0 / 13.6 / 16.0
Sound Power Rating [dB(A)] ^②	71	71	71
Performance Heating^①			
(High Temp.) BTUH / COP (High)	44500 / 4.0	44500 / 4.0	44500 / 4.0
Power Input (KW)	3.26	3.26	3.26
(Low Temp.) BTUH / COP (High)	27000 / 2.67	27000 / 2.67	27000 / 2.67
Power Input (KW)	2.96	2.96	2.96
(High Temp.) BTUH / COP (Low)	32400 / 4.0	32400 / 4.0	32400 / 4.0
Power Input (KW)	2.37	2.37	2.37
(Low Temp.) BTUH / COP (Low)	18500 / 2.42	18500 / 2.42	18500 / 2.42
Power Input (KW)	2.24	2.24	2.24
HSPF (BTU / Watt-Hr.) ^⑥	9.0	9.0	9.0
POWER CONN. — V/Ph/Hz	208-230/1/60	208-230/3/60	460/3/60
Min. Brch. Cir. Ampacity ^③	34.1	24.5	15.3
Fuse Size — Max. / Recmd. (amps)	50 / 50	35 / 35	20 / 20
COMPRESSOR	2-STAGE SCROLL	2-STAGE SCROLL	2-STAGE SCROLL
Volts/Ph/Hz	208-230/1/60	208-230/3/60	460/3/60
R.L. Amps — L.R. Amps	21.2 / 96.0	13.5 / 88.0	6.4 / 41.0
OUTDOOR COIL — TYPE	SPINE-FIN	SPINE-FIN	SPINE-FIN
Rows/F.P.I.	2 / 24	2 / 24	2 / 24
Face Area (sq.ft.)	23.57	23.57	23.57
Tube Size (in.)	3/8	3/8	3/8
Refrigerant Control	EXPANSION VALVE	EXPANSION VALVE	EXPANSION VALVE
INDOOR COIL — TYPE	PLATE FIN	PLATE FIN	PLATE FIN
Rows/F.P.I.	4 / 15	4 / 15	4 / 15
Face Area (sq.ft.)	5.0	5.0	5.0
Tube Size (in.)	3/8	3/8	3/8
Refrigerant Control	EXPANSION VALVE	EXPANSION VALVE	EXPANSION VALVE
Drain Conn. Size (in.)	3/4 FEMALE NPT	3/4 FEMALE NPT	3/4 FEMALE NPT
OUTDOOR FAN — TYPE	PROPELLER	PROPELLER	PROPELLER
Dia. (in.)	28.2	28.2	28.2
Drive/No. Speeds	DIRECT / 1	DIRECT / 1	DIRECT / 1
CFM @ 0.0 in. w.g. ^④	4200	4200	4200
Motor — HP/R.P.M.	1/6 / 830	1/6 / 830	1/6 / 830
Volts/Ph/Hz	208-230/1/60	208-230/1/60	460/1/60
F.L. Amps/L.R. Amps	0.9 / 1.65	0.9 / 1.65	0.5 / 0.84
INDOOR FAN — TYPE	CENTRIFUGAL	CENTRIFUGAL	CENTRIFUGAL
Dia x Width (in.)	10 X 10	10 X 10	10 X 10
Drive/No. Speeds	DIRECT / VARIABLE	DIRECT / VARIABLE	DIRECT / VARIABLE
CFM @ 0.0 in. w.g. ^⑤	SEE FAN PERFORMANCE TABLE	SEE FAN PERFORMANCE TABLE	SEE FAN PERFORMANCE TABLE
Motor — HP/R.P.M.	3/4 / VARIABLE	3/4 / VARIABLE	3/4 / VARIABLE
Volts/Ph/Hz	208-230/1/60	208-230/1/60	208-230/1/60
F.L. Amps/L.R. Amps	6.8 / 6.8	6.8 / 6.8	6.8 / 6.8
FILTER / FURNISHED	NO	NO	NO
Type Recommended	THROWAWAY	THROWAWAY	THROWAWAY
Recmd. Face Area (sq. ft.) ^⑦	5.3	5.3	5.3
REFRIGERANT / Charge (lbs.)	R410A / 8.8	R410A / 8.8	R410A / 8.8
DIMENSIONS	H X W X L	H X W X L	H X W X L
Crated (in.)	52.0 / 47.0 / 62.0	52.0 / 47.0 / 62.0	52.0 / 47.0 / 62.0
WEIGHT / Shipping / Net (lbs.)	607 / 479	607 / 479	607 / 479

① Certified in accordance with the Unitary Air-Conditioner Equipment certification program, which is based on ARI Standard 210/240.

② Sound Power values are not adjusted for ARI 270-95 tonal corrections.

③ Calculated in accordance with currently prevailing Nat'l Electrical Code.

④ Standard Air — Dry Coil — Outdoor.

⑤ Standard Air — Wet Coil — Indoor.

⑥ Rated in accordance with D.O.E. test procedure.

⑦ Filters must be installed in return air system. Square footages listed are based on 300 f.p.m. face velocity. If permanent filters are used size per manufacturer's recommendations with clean resistance of 0.05" W.C.

General Data

MODEL	4WCZ6060A1000A	4WCZ6060A3000A	4WCZ6060A4000A
RATED Volts/PH/Hz	208-230/1/60	208-230/3/60	460/3/60
Performance Cooling			
BTUH (High)	56500	56500	56500
Indoor Airflow (CFM)	1900	1900	1900
Power Input (KW)	4.18	4.18	4.18
BTUH (Low)	40800	40800	40800
Indoor Airflow (CFM)	1350	1350	1350
Power Input (KW)	3.23	3.23	3.23
EER - HI / LOW / SEER	11.5 / 12.5 / 15.2	11.5 / 12.5 / 15.2	11.5 / 12.5 / 15.2
Sound Power Rating [dB(A)] ^②	73	73	73
Performance Heating^③			
(High Temp.) BTUH / COP (High)	55000 / 3.85	55000 / 3.85	55000 / 3.85
Power Input (KW)	4.18	4.18	4.18
(Low Temp.) BTUH / COP (High)	35000 / 2.58	35000 / 2.58	35000 / 2.58
Power Input (KW)	3.97	3.97	3.97
(High Temp.) BTUH / COP (Low)	38900 / 3.8	38900 / 3.8	38900 / 3.8
Power Input (KW)	3.14	3.14	3.14
(Low Temp.) BTUH / COP (Low)	22800 / 2.2	22800 / 2.2	22800 / 2.2
Power Input (KW)	3.04	3.04	3.04
HSPF (BTU / Watt-Hr.) ^④	8.6	8.6	8.6
POWER CONN. — V/Ph/Hz	208-230/1/60	208-230/3/60	460/3/60
Min. Brch. Cir. Ampacity ^⑤	37.1	30.3	19.2
Fuse Size — Max. / Recmd. (amps)	60 / 60	45 / 45	25 / 25
COMPRESSOR	2-STAGE SCROLL	2-STAGE SCROLL	2-STAGE SCROLL
Volts/Ph/Hz	208-230/1/60	208-230/3/60	460/3/60
R.L. Amps — L.R. Amps	23.0 / 118.0	17.6 / 123.0	9.2 / 62.0
OUTDOOR COIL — TYPE	SPINE-FIN	SPINE-FIN	SPINE-FIN
Rows/F.P.I.	2 / 24	2 / 24	2 / 24
Face Area (sq.ft.)	23.57	23.57	23.57
Tube Size (in.)	3/8	3/8	3/8
Refrigerant Control	EXPANSION VALVE	EXPANSION VALVE	EXPANSION VALVE
INDOOR COIL — TYPE	PLATE FIN	PLATE FIN	PLATE FIN
Rows/F.P.I.	4 / 15	4 / 15	4 / 15
Face Area (sq.ft.)	5.0	5.0	5.0
Tube Size (in.)	3/8	3/8	3/8
Refrigerant Control	EXPANSION VALVE	EXPANSION VALVE	EXPANSION VALVE
Drain Conn. Size (in.)	3/4 FEMALE NPT	3/4 FEMALE NPT	3/4 FEMALE NPT
OUTDOOR FAN — TYPE	PROPELLER	PROPELLER	PROPELLER
Dia. (in.)	28.2	28.2	28.2
Drive/No. Speeds	DIRECT / 1	DIRECT / 1	DIRECT / 1
CFM @ 0.0 in. w.g. ^④	4700	4700	4700
Motor — HP/R.P.M.	1/4 / 830	1/4 / 830	1/4 / 830
Volts/Ph/Hz	208-230/1/60	208-230/1/60	460/1/60
F.L. Amps/L.R. Amps	1.4 / 3.37	1.4 / 3.37	0.7 / 1.68
INDOOR FAN — TYPE	CENTRIFUGAL	CENTRIFUGAL	CENTRIFUGAL
Dia x Width (in.)	11 X 10	11 X 10	11 X 10
Drive/No. Speeds	DIRECT / VARIABLE	DIRECT / VARIABLE	DIRECT / VARIABLE
CFM @ 0.0 in. w.g. ^⑤	SEE FAN PERFORMANCE TABLE	SEE FAN PERFORMANCE TABLE	SEE FAN PERFORMANCE TABLE
Motor — HP/R.P.M.	1 / VARIABLE	1 / VARIABLE	1 / VARIABLE
Volts/Ph/Hz	208-230/1/60	208-230/1/60	208-230/1/60
F.L. Amps/L.R. Amps	6.9 / 6.9	6.9 / 6.9	6.9 / 6.9
FILTER / FURNISHED	NO	NO	NO
Type Recommended	THROWAWAY	THROWAWAY	THROWAWAY
Recmd. Face Area (sq. ft.) ^⑦	6.7	6.7	6.7
REFRIGERANT / Charge (lbs.)	R410A / 9.4	R410A / 9.4	R410A / 9.4
DIMENSIONS	H X W X L	H X W X L	H X W X L
Crated (in.)	52.0 / 47.0 / 62.0	52.0 / 47.0 / 62.0	52.0 / 47.0 / 62.0
WEIGHT / Shipping / Net (lbs.)	623 / 495	623 / 495	623 / 495

① Certified in accordance with the Unitary Air-Conditioner Equipment certification program, which is based on ARI Standard 210/240.

② Sound Power values are not adjusted for ARI 270-95 tonal corrections.

③ Calculated in accordance with currently prevailing Nat'l Electrical Code.

④ Standard Air — Dry Coil — Outdoor.

⑤ Standard Air — Wet Coil — Indoor.

⑥ Rated in accordance with D.O.E. test procedure.

⑦ Filters must be installed in return air system. Square footages listed are based on 300 f.p.m. face velocity. If permanent filters are used size per manufacturer's recommendations with clean resistance of 0.05" W.C.

Heater Data

Table 1. 4WCZ6036A to 4WCZ6060A Heater Data

UNIT MODEL	ELECTRIC HEATER MODEL	RATED VOLTAGE	PHASE	AMPS	HEATER CAPACITY		NO. OF STAGES	KW/STAGE		MCA	MAX FUSE OR HACR CKT BKR SIZE (4)	CANADA ONLY MAX. CKT BKR SIZE (5)
					KW	BTUH		1	2			
^W/TC*3018-060A1 ^W/TCY4024-060A1 ^WCZ6036-060A1	BAYHTRV105E	208/240	1	18/21	3.76/5.0	12800/17100	1	3.76/5.0		23/26	25/30	25/30
^W/TC*3018-060A1 ^W/TCY4024-060A1 ^WCZ6036-060A1	BAYHTRV108E	208/240	1	29/33	6.0/8.0	20500/27300	1	6.0/8.0		36/41	40/45	40/45
^W/TC*3024-060A1 ^W/TCY4024-060A1 ^WCZ6036-060A1	BAYHTRV110E	208/240	1	36/42	7.5/10.0	25600/34100	1	7.5/10.0		45/52	45/60	45/60
^W/TC*3030-060A1 ^W/TCY4030-060A1 ^WCZ6036-060A1	BAYHTRV115E#	208/240	1	54/63	11.27/15.0	38500/51200	2	7.5/10.0	3.76/5.0	68/78	70/80	70/80
^W/TC*3048-060A1 ^W/TCY4042-060A1 ^WCZ6048-060A1	BAYHTRV120E#	208/240	1	72/83	15.0/20.0	51200/68300	2	7.5/10.0	7.5/10.0	90/104	90/110	90/110
^W/TC*3060A1 ^W/TCY4042-060A1 ^WCZ6048-060A1	BAYHTRV125E#	208/240	1	90/104	18.78/25.0	64100/85300	2	11.26/15.0	7.5/10.0	113/130	125/150	125/150
^W/TC*3036-060A3 ^W/TCY4036-060A3 ^WCZ6036-060A3	BAYHTRV305E	208/240	3	10/12	3.76/5.0	12800/17100	1	3.76/5.0		13/15	15/15	15/15
^W/TC*3036-060A3 ^W/TCY4036-060A3 ^WCZ6036-060A3	BAYHTRV308E	208/240	3	17/19	6.0/8.0	20500/27300	1	6.0/8.0		21/24	25/25	25/25
^W/TC*3036-060A3 ^W/TCY4036-060A3 ^WCZ6036-060A3	BAYHTRV310E	208/240	3	21/24	7.5/10.0	25600/34100	1	7.5/10.0		26/30	30/30	30/30
^W/TC*3036-060A3 ^W/TCY4036-060A3 ^WCZ6036-060A3	BAYHTRV315E	208/240	3	31/36	11.27/15.0	38500/51200	2	7.5/10.0	3.76/5.0	39/45	40/45	40/45
^W/TC*3048-060A3 ^W/TCY4048-060A3 ^WCZ6048-060A3	BAYHTRV320E	208/240	3	42/48	15.0/20.0	51200/68300	2	7.5/10.0	7.5/10.0	52/60	60/60	60/60
^W/TC*3060A3 ^W/TCY4048-060A3 ^WCZ6048-060A3	BAYHTRV325E#	208/240	3	52/60	18.78/25.0	64100/85300	2	11.26/15.0	7.5/10.0	65/75	70/80	70/80
^W/TC*3036-060A4 ^WCZ6036-060A4	BAYHTRV405E	480	3	6	5.0	17100	1	5.0		8	15	15
^W/TC*3036-060A4 ^WCZ6036-060A4	BAYHTRV408E	480	3	10	8.0	27300	1	8.0		13	15	15
^W/TC*3036-060A4 ^WCZ6036-060A4	BAYHTRV410E	480	3	12	10.0	34100	1	10.0		15	15	15
^W/TC*3036-060A4 ^WCZ6036-060A4	BAYHTRV415E	480	3	18	15.0	51200	2	10.0	5.0	23	25	25
^W/TC*3048-060A4 ^WCZ6048-060A4	BAYHTRV420E	480	3	24	20.0	68300	2	10.0	10.0	30	30	30
^W/TC*3060A4 ^WCZ6048-060A4	BAYHTRV425E	480	3	30	25.0	85300	2	15.0	10.0	38	40	40

NOTES:

1. Any power supply and circuits must be wired and protected in accordance with local electrical codes.
 2. The MCA values listed are for electric heater only.
 3. Field wire must be rated at least 75°C
 4. The HACR circuit breaker is for U.S.A. installations only.
 5. For Canada installation reference only.
- # Heater uses fuses.

Single Power Entry Kit Data

Table 2. BAYSPEK060E Ampacity and Max Fusing/Circuit Breakers

SINGLE POWER ENTRY KIT	HEATER MODEL	UNIT MODEL	MIN CKT. AMP.	MAX OVER CURRENT PROTECT DEVICE
BAYSPEK060E	BAYHTRV105E	4TC*3018A1	27	30
		4TC*3024A1	28	30
		4TC*3030A1	29	35
		4TC*3036A1	30	35
		4TC*3042A1	29	45
		4TC*3048A1	31	50
		4TCY4024A1	31	35
		4TCY4030A1	31	35
		4TCY4036A1	31	40
		4TCY4042A1	35	50
		4TCY4048A1	35	50
		4TCY4060A1	42	60
		2WC*3024A1	39	40
		2WC*3030A1	43	45
		2WC*3036A1	50	60
		2WC*3042A1	51	60
		2WC*3048A1	55	60
		4WC*3018A1	37	40
		4WC*3036A1	52	60
		4WCY4024A1	42	45
	4WCY4030A1	45	50	
	4WCY4036A1	51	60	
	4WCZ6036A1	52	60	
	BAYHTRV108E	4TC*3018A1	43	45
		4TC*3024A1	43	45
		4TC*3030A1	44	45
		4TC*3036A1	45	45
		4TC*3042A1	45	45
		4TC*3048A1	47	50
		4TCY4024A1	47	50
		4TCY4030A1	47	50
		4TCY4036A1	47	50
		4TCY4042A1	50	60
		4TCY4048A1	50	60
		4TCY4060A1	50	60
		2WC*3024A1	54	60
		2WC*3030A1	59	60
		4WC*3018A1	52	60
	4WCY4024A1	58	60	
	BAYHTRV110E	4TC*3024A1	54	60
		4TC*3030A1	55	60
		4TC*3036A1	56	60
		4TC*3042A1	55	60
		4TC*3048A1	57	60
		4TCY4024A1	58	60
4TCY4030A1		58	60	
4TCY4036A1	58	60		

INSTALLER OF THE SINGLE POWER ENTRY KIT MUST CHECK THE APPROPRIATE BOX ABOVE TO RECORD THE KIT, HEATER AND UNIT MODEL NUMBERS INSTALLED. POWER SUPPLY VOLTAGE TO UNIT AND HEATER MUST BE IDENTICAL. CHECK THE UNIT AND HEATER NAMEPLATES TO DETERMINE THE CORRECT POWER SUPPLY VOLTAGE. CHECK HEATER NAMEPLATE TO DETERMINE HEATER KW AND CURRENT RATING. MINIMUM INSTALLATION CLEARANCE TO COMBUSTIBLE MATERIAL WHEN ELECTRIC HEATERS ARE INSTALLED: UNIT CABINET-0", PLENUM-0" AND OUTLET DUCT- 0".
 * INDICATES AN ALPHA CHARACTER IN THE FOURTH DIGIT OF THE UNIT MODEL.

D932299P01

Single Power Entry Kit Data

Table 3. BAYSPEK061E Ampacity and Max Fusing/Circuit Breakers

SINGLE POWER ENTRY KIT	HEATER MODEL	UNIT MODEL	MIN CKT. AMP.	MAX OVER CURRENT PROTECT DEVICE	
BAYSPEK061E	BAYHTRV305E	4TC*3036A3	18	30	
		4TC*3048A3	24	35	
		4TC*3060A3	32	45	
		4TCY4036A3	20	30	
		4TCY4048A3	26	40	
		4TCY4060A3	31	45	
		4WC*3036A3	33	40	
		4WC*3048A3	39	50	
		4WC*3060A3	47	60	
		4WCY4036A3	35	40	
		4WCY4048A3	41	50	
		4WCY4060A3	46	60	
		4WCZ6036A3	34	40	
		4WCZ6048A3	40	50	
		4WCZ6060A3	45	60	
	BAYHTRV308E	4TC*3036A3	27	30	
		4TC*3048A3	29	35	
		4TC*3060A3	34	45	
		4TCY4036A3	29	30	
		4TCY4048A3	33	40	
		4TCY4060A3	33	45	
		4WC*3036A3	42	45	
		4WC*3048A3	48	50	
		4WC*3060A3	56	60	
		4WCY4036A3	44	50	
		4WCY4048A3	50	60	
		4WCY4060A3	55	60	
		4WCZ6036A3	43	45	
		4WCZ6048A3	49	50	
		4WCZ6060A3	54	60	
	BAYHTRV310E	4TC*3036A3	33	35	
		4TC*3048A3	35	35	
		4TC*3060A3	40	45	
		4TCY4036A3	35	35	
		4TCY4048A3	39	40	
		4TCY4060A3	39	45	
		4WC*3036A3	48	50	
		4WC*3048A3	54	60	
		4WCY4036A3	50	50	
		4WCY4048A3	56	60	
		4WCZ6036A3	49	50	
		4WCZ6048A3	55	60	
		BAYHTRV315E	4TC*3036A3	48	50
			4TC*3048A3	50	50
			4TC*3060A3	55	60
4TCY4036A3	50		50		
4TCY4048A3	54		60		
4TCY4060A3	54		60		
BAYSPEK061E	BAYHTRV405E	4TC*3036A4	10	15	
		4TC*3048A4	12	15	
		4TC*3060A4	20	25	
		4WC*3036A4	16	20	
		4WC*3048A4	19	25	
		4WC*3060A4	27	30	
		4WCZ6036A4	18	20	
		4WCZ6048A4	23	25	
		4WCZ6060A4	27	30	
		BAYHTRV408E	4TC*3036A4	14	15
	4TC*3048A4		15	15	
	4TC*3060A4		22	25	
	4WC*3036A4		21	25	
	4WC*3048A4		24	25	
	4WC*3060A4		32	35	
	4WCZ6036A4		22	25	
	4WCZ6048A4		27	30	
	4WCZ6060A4		31	35	
	BAYHTRV410E		4TC*3036A4	17	20
		4TC*3048A4	18	20	
		4TC*3060A4	25	25	
		4WC*3036A4	24	25	
		4WC*3048A4	27	30	
		4WC*3060A4	35	40	
		4WCZ6036A4	25	25	
		4WCZ6048A4	30	30	
		4WCZ6060A4	34	40	
		BAYHTRV415E	4TC*3036A4	25	25
	4TC*3048A4		25	25	
	4TC*3060A4		32	35	
	4WC*3036A4		31	35	
	4WC*3048A4		34	35	
	4WC*3060A4		42	45	
	4WCZ6036A4		33	35	
	4WCZ6048A4		38	40	
	4WCZ6060A4		42	45	
	BAYHTRV420E		4TC*3048A4	33	35
		4TC*3060A4	40	40	
		4WC*3048A4	42	45	
		4WC*3060A4	50	50	
		4WCZ6048A4	45	45	
		4WCZ6060A4	49	50	

INSTALLER OF THE SINGLE POWER ENTRY KIT MUST CHECK THE APPROPRIATE BOX ABOVE TO RECORD THE KIT, HEATER AND UNIT MODEL NUMBERS INSTALLED. POWER SUPPLY VOLTAGE TO UNIT AND HEATER MUST BE IDENTICAL. CHECK THE UNIT AND HEATER NAMEPLATES TO DETERMINE THE CORRECT POWER SUPPLY VOLTAGE. CHECK HEATER NAMEPLATE TO DETERMINE HEATER KW AND CURRENT RATING. MINIMUM INSTALLATION CLEARANCE TO COMBUSTIBLE MATERIAL WHEN ELECTRIC HEATERS ARE INSTALLED: UNIT CABINET-0", PLENUM-0" AND OUTLET DUCT-0" EXCEPT FOR BAYHTRV415E AND BAYHTRV425E WHEN INSTALLED IN 4WCZ6060A4 UNIT ONLY. MINIMUM INSTALLATION CLEARANCE TO COMBUSTIBLE MATERIAL WHEN BAYHTRV415E AND BAYHTRV425E ARE INSTALLED IN 4WCZ6060A4 UNIT ONLY: UNIT CABINET - 1", PLENUM - 1" AND OUTLET DUCT - 1".
 * INDICATES AN ALPHA CHARACTER IN THE FOURTH DIGIT OF THE UNIT MODEL.
 D932299P02

Single Power Entry Kit Data

Table 4. BAYSPEK062E,63E,64E & 65E Ampacity and Max Fusing/Circuit Breakers

SINGLE POWER ENTRY KIT	HEATER MODEL	UNIT MODEL	MIN CKT. AMP.	MAX OVER CURRENT PROTECT DEVICE	SINGLE POWER ENTRY KIT	HEATER MODEL	UNIT MODEL	MIN CKT. AMP.	MAX OVER CURRENT PROTECT DEVICE	
BAYSPEK062E	BAYHTRV105E	4TC*3060A1	44	70	BAYSPEK063E	BAYHTRV115E	2WC*3036A1	102	110	
		2WC*3060A1	67	80			2WC*3042A1	103	110	
		4WC*3048A1	57	70			2WC*3048A1	107	110	
		4WC*3060A1	70	90			2WC*3060A1	119	125	
		4WCY4042A1	58	70			4WC*3036A1	104	110	
		4WCY4048A1	60	70			4WC*3048A1	109	110	
		4WCY4060A1	68	90			4WC*3060A1	122	125	
		4WCZ6048A1	60	70			4WCY4030A1	97	100	
		4WCZ6060A1	63	80			4WCY4036A1	103	110	
		BAYHTRV108E	4TC*3060A1	51			70	4WCY4042A1	110	110
			2WC*3036A1	66			70	4WCY4048A1	112	125
			2WC*3042A1	66			70	4WCY4060A1	120	125
	2WC*3048A1		70	80		4WCZ6036A1	104	110		
	2WC*3060A1		82	90		4WCZ6048A1	112	125		
	4WC*3036A1		67	70		4WCZ6060A1	115	125		
	4WC*3048A1		73	80		BAYHTRV120E	4TC*3048A1	109	110	
	4WC*3060A1		85	100			4TC*3060A1	114	125	
	4WCY4030A1		61	70			4TCY4042A1	113	125	
	4WCY4036A1		66	70			4TCY4048A1	113	125	
	4WCY4042A1		73	80			4TCY4060A1	113	125	
	4WCY4048A1		76	80			2WC*3048A1	133	150	
	4WCY4060A1	84	100	2WC*3060A1			145	150		
	4WCZ6036A1	68	70	4WC*3048A1			135	150		
	4WCZ6048A1	76	80	4WC*3060A1			148	150		
	4WCZ6060A1	79	90	4WCY4042A1			136	150		
	BAYSPEK064E	BAYHTRV110E	4TC*3060A1	62			70	4WCY4048A1	138	150
			4TCY4042A1	61			70	4WCY4060A1	146	150
			4TCY4048A1	61		70	4WCZ6048A1	138	150	
			4TCY4060A1	61		70	4WCZ6060A1	141	150	
			2WC*3024A1	65		70	BAYHTRV315E	4WC*3036A3	63	70
			2WC*3030A1	69		70		4WC*3048A3	69	70
			2WC*3036A1	76		80		4WC*3060A3	77	80
			2WC*3042A1	77		80		4WCY4036A3	65	70
			2WC*3048A1	81		90		4WCY4048A3	71	80
			2WC*3060A1	93		100		4WCY4060A3	76	80
			4WC*3036A1	78		80		4WCZ6036A3	64	70
			4WC*3048A1	83		90		4WCZ6048A3	70	70
		4WC*3060A1	96	110		4WCZ6060A3		75	80	
		4WCY4024A1	68	70		BAYHTRV320E		4TC*3048A3	65	70
		4WCY4030A1	71	80				4TC*3060A3	70	70
		4WCY4036A1	77	80				4TCY4048A3	69	70
		4WCY4042A1	84	90			4TCY4060A3	69	70	
		4WCY4048A1	86	90			4WC*3048A3	84	90	
		4WCY4060A1	94	110			4WC*3060A3	92	100	
		4WCZ6036A1	78	80			4WCY4048A3	86	90	
		4WCZ6048A1	86	90			4WCY4060A3	91	100	
		4WCZ6060A1	89	100			4WCZ6048A3	85	90	
		BAYSPEK063E	BAYHTRV115E	4TC*3030A1			81	90	4WCZ6060A3	90
4TC*3036A1				82	90		4WC*3060A3	62	70	
4TC*3042A1	81			90	4WCY4060A3		61	70		
4TC*3048A1	83			90	4WCZ6060A3	60	70			
4TC*3060A1	88			90	INSTALLER OF THE SINGLE POWER ENTRY KIT MUST CHECK THE APPROPRIATE BOX ABOVE TO RECORD THE KIT, HEATER AND UNIT MODEL NUMBERS INSTALLED. POWER SUPPLY VOLTAGE TO UNIT AND HEATER MUST BE IDENTICAL. CHECK THE UNIT AND HEATER NAMEPLATES TO DETERMINE THE CORRECT POWER SUPPLY VOLTAGE. CHECK HEATER NAMEPLATE TO DETERMINE HEATER KW AND CURRENT RATING. MINIMUM INSTALLATION CLEARANCE TO COMBUSTIBLE MATERIAL WHEN ELECTRIC HEATERS ARE INSTALLED: UNIT CABINET-0", PLENUM-0" AND OUTLET DUCT- 0". * INDICATES AN ALPHA CHARACTER IN THE FOURTH DIGIT OF THE UNIT MODEL.					
4TCY4030A1	84			90						
4TCY4036A1	84			90						
4TCY4042A1	87			90						
4TCY4048A1	87			90						
4TCY4060A1	87			90						
2WC*3030A1	95			100						

D932299P03

Performance Data Cooling

HIGH STAGE: 4WCZ6036A AT 1200 NOM CFM (COOLING PERFORMANCE AT INDOOR DRY BULB TEMPERATURES)

OD AMB	ID WB	TOT CAP	SENS CAP AT ENTERING DB TEMP				TOTAL KW
			72	75	78	80	
85	59	34.9	29.0	32.6	34.9	34.9	2.7
	63	36.4	23.6	27.2	30.7	33.1	2.7
	67	39.2	18.7	22.2	25.8	28.1	2.8
	71	42.4	13.7	17.3	20.8	23.2	2.8
95	59	32.3	27.8	31.4	32.3	32.3	2.9
	63	33.7	22.5	26.1	29.6	32.0	3.0
	67	36.3	17.6	21.1	24.7	27.1	3.0
	71	39.2	12.6	16.2	19.7	22.1	3.0
105	59	29.8	26.7	29.8	29.8	29.8	3.2
	63	31.0	21.4	25.0	28.5	30.9	3.2
	67	33.4	16.5	20.0	23.6	26.0	3.3
	71	36.1	11.6	15.1	18.7	21.0	3.3
115	59	27.2	25.5	27.2	27.2	27.2	3.4
	63	28.3	20.3	23.9	27.5	28.3	3.4
	67	30.5	15.4	19.0	22.5	24.9	3.5
	71	33.0	10.5	14.1	17.6	20.0	3.5

USE THE FOLLOWING FACTORS TO COMPENSATE FOR DIFFERENT AIR FLOW

	AIR FLOW RATE, CFM	CAPACITY MULTIPLIER	TOTAL POWER MULTIPLIER
LOW	1050	0.97	0.98
HIGH	1350	1.03	1.02

ARI RATING FOR COOLING

CFM	CAPACITY (A) TEST	SEER	EER
1140	36000	16.40	12.00

ARI Standard Capacity Rating Conditions

ARI STANDARD 210/240 RATING CONDITIONS — (A) Cooling 80°F DB, 67°F WB air entering indoor coil, 95°F DB air entering outdoor coil. (B) High Temperature Heating 47°F DB, 43°F WB air entering outdoor coil, 70°F DB air entering indoor coil. (C) Low Temperature Heating 17°F DB, 15°F WB air entering outdoor coil, 70°F DB air entering indoor coil. (D) Rated indoor airflow for heating is the same as for cooling.

LOW STAGE: 4WCZ6036A AT 900 NOM CFM (COOLING PERFORMANCE AT INDOOR DRY BULB TEMPERATURES)

OD AMB	ID WB	TOT CAP	SENS CAP AT ENTERING DB TEMP				TOTAL KW
			72	75	78	80	
75	59	25.3	21.3	24.0	25.3	25.3	1.3
	63	26.4	17.4	20.0	22.6	24.4	1.4
	67	28.4	13.7	16.4	19.0	20.8	1.4
	71	30.7	10.1	12.7	15.3	17.1	1.4
85	59	23.5	20.5	23.2	23.5	23.5	1.6
	63	24.5	16.6	19.2	21.9	23.6	1.6
	67	26.4	12.9	15.6	18.2	20.0	1.6
	71	28.5	9.3	11.9	14.6	16.3	1.6
90	59	22.5	20.1	22.5	22.5	22.5	1.7
	63	23.5	16.2	18.8	21.5	23.2	1.7
	67	25.3	12.5	15.2	17.8	19.6	1.7
	71	27.3	8.9	11.6	14.2	15.9	1.7
95	59	21.6	19.7	21.6	21.6	21.6	1.8
	63	22.5	15.8	18.4	21.1	22.5	1.8
	67	24.3	12.2	14.8	17.5	19.2	1.8
	71	26.2	8.5	11.2	13.8	15.6	1.8

USE THE FOLLOWING FACTORS TO COMPENSATE FOR DIFFERENT AIR FLOW

	AIR FLOW RATE, CFM	CAPACITY MULTIPLIER	TOTAL POWER MULTIPLIER
LOW	790	0.97	0.98
HIGH	1010	1.03	1.02

ARI RATING FOR COOLING

CFM	CAPACITY (A) TEST	SEER	EER
840	25247	16.40	13.35

ARI Standard Capacity Rating Conditions

ARI STANDARD 210/240 RATING CONDITIONS — (A) Cooling 80°F DB, 67°F WB air entering indoor coil, 95°F DB air entering outdoor coil. (B) High Temperature Heating 47°F DB, 43°F WB air entering outdoor coil, 70°F DB air entering indoor coil. (C) Low Temperature Heating 17°F DB, 15°F WB air entering outdoor coil, 70°F DB air entering indoor coil. (D) Rated indoor airflow for heating is the same as for cooling.

HIGH STAGE: 4WCZ6048A AT 1600 NOM CFM (COOLING PERFORMANCE AT INDOOR DRY BULB TEMPERATURES)

OD AMB	ID WB	TOT CAP	SENS CAP AT ENTERING DB TEMP				TOTAL KW
			72	75	78	80	
85	59	45.2	38.6	43.6	45.2	45.2	3.6
	63	47.1	31.2	36.2	41.1	44.4	3.6
	67	50.8	24.4	29.3	34.3	37.6	3.6
	71	54.8	17.5	22.5	27.4	30.7	3.6
95	59	42.4	37.4	42.3	42.4	42.4	3.9
	63	44.2	30.0	34.9	39.9	43.2	3.9
	67	47.6	23.2	28.2	33.1	36.3	4.0
	71	51.4	16.4	21.3	26.2	29.5	4.0
105	59	39.6	36.1	39.6	39.6	39.6	4.2
	63	41.3	28.9	33.8	38.7	41.3	4.2
	67	44.5	22.1	27.0	31.9	35.2	4.3
	71	48.0	15.2	20.1	25.1	28.4	4.3
115	59	36.8	34.9	36.8	36.8	36.8	4.5
	63	38.3	27.7	32.6	37.5	38.3	4.5
	67	41.3	20.9	25.8	30.8	34.1	4.6
	71	44.6	14.1	19.0	24.0	27.2	4.6

USE THE FOLLOWING FACTORS TO COMPENSATE FOR DIFFERENT AIR FLOW

	AIR FLOW RATE, CFM	CAPACITY MULTIPLIER	TOTAL POWER MULTIPLIER
LOW	1400	0.97	0.98
HIGH	1800	1.03	1.02

ARI RATING FOR COOLING

CFM	CAPACITY (A) TEST	SEER	EER
1580	47500	16.00	12.00

ARI Standard Capacity Rating Conditions

ARI STANDARD 210/240 RATING CONDITIONS — (A) Cooling 80°F DB, 67°F WB air entering indoor coil, 95°F DB air entering outdoor coil. (B) High Temperature Heating 47°F DB, 43°F WB air entering outdoor coil, 70°F DB air entering indoor coil. (C) Low Temperature Heating 17°F DB, 15°F WB air entering outdoor coil, 70°F DB air entering indoor coil. (D) Rated indoor airflow for heating is the same as for cooling.

Performance Data Cooling

LOW STAGE: 4WCZ6048A AT 1200 NOM CFM (COOLING PERFORMANCE AT INDOOR DRY BULB TEMPERATURES)

OD AMB	ID WB	TOT CAP	SENS CAP AT ENTERING DB TEMP				TOTAL KW
			72	75	78	80	
75	59	34.5	29.5	33.2	34.5	34.5	1.8
	63	35.9	23.9	27.6	31.3	33.8	1.9
	67	38.7	18.8	22.5	26.2	28.7	1.9
	71	41.8	13.7	17.4	21.1	23.6	1.9
85	59	32.2	28.5	32.2	32.2	32.2	2.1
	63	33.6	22.9	26.7	30.3	32.8	2.2
	67	36.2	17.8	21.5	25.3	27.7	2.2
	71	39.0	12.7	16.4	20.1	22.6	2.2
90	59	31.0	27.9	31.0	31.0	31.0	2.3
	63	32.4	22.4	26.2	29.9	32.3	2.3
	67	34.9	17.4	21.0	24.8	27.2	2.3
	71	37.7	12.3	16.0	19.6	22.1	2.3
95	59	29.9	27.5	29.9	29.9	29.9	2.4
	63	31.2	22.0	25.7	29.4	31.2	2.4
	67	33.6	16.9	20.6	24.3	26.8	2.5
	71	36.3	11.8	15.5	19.2	21.6	2.5

USE THE FOLLOWING FACTORS TO COMPENSATE FOR DIFFERENT AIR FLOW

	AIR FLOW RATE, CFM	CAPACITY MULTIPLIER	TOTAL POWER MULTIPLIER
LOW	1050	0.97	0.98
HIGH	1350	1.03	1.02

ARI RATING FOR COOLING

CFM	CAPACITY (A) TEST	SEER	EER
1175	35110	16.00	13.54

ARI Standard Capacity Rating Conditions

ARI STANDARD 210/240 RATING CONDITIONS — (A) Cooling 80°F DB, 67°F WB air entering indoor coil, 95°F DB air entering outdoor coil. (B) High Temperature Heating 47°F DB, 43°F WB air entering outdoor coil, 70°F DB air entering indoor coil. (C) Low Temperature Heating 17°F DB, 15°F WB air entering outdoor coil, 70°F DB air entering indoor coil. (D) Rated indoor airflow for heating is the same as for cooling.

HIGH STAGE: 4WCZ6060A AT 2000 NOM CFM (COOLING PERFORMANCE AT INDOOR DRY BULB TEMPERATURES)

OD AMB	ID WB	TOT CAP	SENS CAP AT ENTERING DB TEMP				TOTAL KW
			72	75	78	80	
85	59	54.1	46.5	52.5	54.1	54.1	4.4
	63	56.4	37.4	43.4	49.5	53.5	4.4
	67	60.8	29.0	35.1	41.1	45.1	4.5
	71	65.6	20.7	26.7	32.7	36.7	4.5
95	59	50.8	45.0	50.8	50.8	50.8	4.8
	63	53.0	36.0	42.0	48.1	52.1	4.9
	67	57.1	27.6	33.7	39.7	43.7	4.9
	71	61.6	19.3	25.3	31.4	35.4	4.9
105	59	47.5	43.6	47.5	47.5	47.5	5.2
	63	49.5	34.6	40.6	46.7	49.5	5.3
	67	53.4	26.3	32.3	38.3	42.3	5.4
	71	57.6	18.0	24.0	30.0	34.0	5.4
115	59	44.2	42.1	44.2	44.2	44.2	5.7
	63	46.1	33.2	39.3	45.3	46.1	5.7
	67	49.6	25.0	31.0	37.0	41.0	5.8
	71	53.6	16.6	22.7	28.7	32.7	5.8

USE THE FOLLOWING FACTORS TO COMPENSATE FOR DIFFERENT AIR FLOW

	AIR FLOW RATE, CFM	CAPACITY MULTIPLIER	TOTAL POWER MULTIPLIER
LOW	1750	0.97	0.98
HIGH	2250	1.03	1.02

ARI RATING FOR COOLING

CFM	CAPACITY (A) TEST	SEER	EER
1895	56500	15.20	11.50

ARI Standard Capacity Rating Conditions

ARI STANDARD 210/240 RATING CONDITIONS — (A) Cooling 80°F DB, 67°F WB air entering indoor coil, 95°F DB air entering outdoor coil. (B) High Temperature Heating 47°F DB, 43°F WB air entering outdoor coil, 70°F DB air entering indoor coil. (C) Low Temperature Heating 17°F DB, 15°F WB air entering outdoor coil, 70°F DB air entering indoor coil. (D) Rated indoor airflow for heating is the same as for cooling.

LOW STAGE: 4WCZ6060A AT 1500 NOM CFM (COOLING PERFORMANCE AT INDOOR DRY BULB TEMPERATURES)

OD AMB	ID WB	TOT CAP	SENS CAP AT ENTERING DB TEMP				TOTAL KW
			72	75	78	80	
75	59	39.7	35.3	39.7	39.7	39.7	2.3
	63	41.4	28.4	33.0	37.6	40.7	2.3
	67	44.6	22.1	26.7	31.3	34.3	2.3
	71	48.1	15.7	20.3	24.9	28.0	2.3
85	59	37.2	34.1	37.2	37.2	37.2	2.6
	63	38.7	27.4	32.0	36.5	38.7	2.7
	67	41.8	21.0	25.6	30.2	33.3	2.7
	71	45.1	14.7	19.3	23.9	27.0	2.7
90	59	35.9	33.6	35.9	35.9	35.9	2.8
	63	37.4	26.8	31.4	36.0	37.4	2.8
	67	40.3	20.5	25.1	29.7	32.8	2.9
	71	43.5	14.2	18.8	23.4	26.4	2.9
95	59	34.6	33.0	34.6	34.6	34.6	3.0
	63	36.1	26.3	30.9	35.5	36.1	3.0
	67	38.9	20.0	24.6	29.2	32.2	3.1
	71	42.0	13.7	18.3	22.9	25.9	3.1

USE THE FOLLOWING FACTORS TO COMPENSATE FOR DIFFERENT AIR FLOW

	AIR FLOW RATE, CFM	CAPACITY MULTIPLIER	TOTAL POWER MULTIPLIER
LOW	1310	0.97	0.98
HIGH	1680	1.03	1.02

ARI RATING FOR COOLING

CFM	CAPACITY (A) TEST	SEER	EER
1320	40436	15.20	12.48

ARI Standard Capacity Rating Conditions

ARI STANDARD 210/240 RATING CONDITIONS — (A) Cooling 80°F DB, 67°F WB air entering indoor coil, 95°F DB air entering outdoor coil. (B) High Temperature Heating 47°F DB, 43°F WB air entering outdoor coil, 70°F DB air entering indoor coil. (C) Low Temperature Heating 17°F DB, 15°F WB air entering outdoor coil, 70°F DB air entering indoor coil. (D) Rated indoor airflow for heating is the same as for cooling.

Performance Data Heating

HIGH STAGE: 4WCZ6036A AT 1200 NOM CFM (HEATING PERFORMANCE AT INDOOR DRY BULB TEMPERATURE)

OD AMB	TOTAL CAPACITY MBH				TOTAL POWER IN KILOWATTS				USE THE FOLLOWING FACTORS TO COMPENSATE FOR DIFFERENT AIR FLOW		
	60	70	75	80	60	70	75	80	AIR FLOW RATE, CFM	CAPACITY MULTIPLIER	TOTAL POWER MULTIPLIER
2	13.7	13.4	13.3	13.2	2.1	2.2	2.3	2.4			
7	16.1	15.8	15.6	15.5	2.1	2.3	2.3	2.4			
12	18.4	18.1	17.9	17.7	2.2	2.3	2.4	2.4			
17	20.8	20.4	20.2	20.0	2.2	2.3	2.4	2.5			
22	20.8	20.4	20.2	20.0	2.2	2.3	2.4	2.5			
27	20.9	20.5	20.3	20.1	2.2	2.3	2.4	2.5			
32	20.9	20.5	20.3	20.1	2.2	2.3	2.4	2.4			
37	23.3	22.8	22.6	22.4	2.2	2.3	2.4	2.5			
42	29.1	28.6	28.3	28.0	2.3	2.5	2.5	2.6			
47	35.0	34.3	34.0	33.7	2.4	2.6	2.7	2.7			
52	37.3	36.6	36.3	36.0	2.5	2.6	2.7	2.8			
57	39.7	39.0	38.6	38.2	2.5	2.7	2.7	2.8			
62	42.1	41.3	40.9	40.5	2.5	2.7	2.8	2.9			
67	44.4	43.6	43.2	42.8	2.6	2.7	2.8	2.9			
72	46.8	45.9	45.5	45.1	2.6	2.8	2.8	2.9			

ARI RATING FOR HEATING					
CFM	CAPACITY 47	COP 47	CAPACITY 17	COP 17	HSPF
1140	34000	3.90	20200	2.55	9.00

ARI Standard Capacity Rating Conditions

ARI STANDARD 210/240 RATING CONDITIONS — (A) Cooling 80°F DB, 67°F WB air entering indoor coil, 95°F DB air entering outdoor coil. (B) High Temperature Heating 47°F DB, 43°F WB air entering outdoor coil, 70°F DB air entering indoor coil. (C) Low Temperature Heating 17°F DB, 15°F WB air entering outdoor coil, 70°F DB air entering indoor coil. (D) Rated indoor airflow for heating is the same as for cooling.

LOW STAGE: 4WCZ6036A AT 900 NOM CFM (HEATING PERFORMANCE AT INDOOR DRY BULB TEMPERATURE)

OD AMB	TOTAL CAPACITY MBH				TOTAL POWER IN KILOWATTS				USE THE FOLLOWING FACTORS TO COMPENSATE FOR DIFFERENT AIR FLOW		
	60	70	75	80	60	70	75	80	AIR FLOW RATE, CFM	CAPACITY MULTIPLIER	TOTAL POWER MULTIPLIER
22	14.4	14.2	14.0	13.9	1.6	1.8	1.8	1.9			
27	15.6	15.3	15.1	15.0	1.7	1.8	1.8	1.9			
32	16.7	16.4	16.3	16.1	1.7	1.8	1.8	1.9			
37	18.4	18.1	17.9	17.7	1.7	1.8	1.8	1.9			
42	20.9	20.5	20.3	20.1	1.7	1.8	1.8	1.9			
47	23.4	23.0	22.8	22.5	1.7	1.8	1.8	1.9			
52	25.1	24.6	24.4	24.2	1.7	1.8	1.8	1.9			
57	26.8	26.3	26.0	25.8	1.7	1.8	1.9	1.9			
62	28.5	28.0	27.7	27.4	1.7	1.8	1.9	1.9			
67	30.2	29.6	29.3	29.0	1.7	1.8	1.9	1.9			
72	31.9	31.3	30.9	30.7	1.7	1.8	1.9	1.9			

ARI RATING FOR HEATING					
CFM	CAPACITY 47	COP 47	CAPACITY 17	COP 17	HSPF
840	22690	3.76	12888	2.19	9.00

ARI Standard Capacity Rating Conditions

ARI STANDARD 210/240 RATING CONDITIONS — (A) Cooling 80°F DB, 67°F WB air entering indoor coil, 95°F DB air entering outdoor coil. (B) High Temperature Heating 47°F DB, 43°F WB air entering outdoor coil, 70°F DB air entering indoor coil. (C) Low Temperature Heating 17°F DB, 15°F WB air entering outdoor coil, 70°F DB air entering indoor coil. (D) Rated indoor airflow for heating is the same as for cooling.

HIGH STAGE: 4WCZ6048A AT 1600 NOM CFM (HEATING PERFORMANCE AT INDOOR DRY BULB TEMPERATURE)

OD AMB	TOTAL CAPACITY MBH				TOTAL POWER IN KILOWATTS				USE THE FOLLOWING FACTORS TO COMPENSATE FOR DIFFERENT AIR FLOW		
	60	70	75	80	60	70	75	80	AIR FLOW RATE, CFM	CAPACITY MULTIPLIER	TOTAL POWER MULTIPLIER
2	17.4	17.1	16.9	16.8	2.5	2.6	2.7	2.8			
7	20.5	20.2	19.9	19.8	2.6	2.7	2.8	2.9			
12	23.6	23.2	23.0	22.8	2.6	2.8	2.9	3.0			
17	26.8	26.3	26.0	25.8	2.7	2.9	2.9	3.0			
22	27.7	27.2	26.9	26.7	2.7	2.9	3.0	3.1			
27	28.6	28.1	27.8	27.6	2.7	2.9	3.0	3.1			
32	29.6	29.0	28.7	28.5	2.8	2.9	3.0	3.1			
37	32.7	32.1	31.8	31.5	2.8	3.0	3.1	3.2			
42	39.1	38.3	38.0	37.6	2.9	3.1	3.2	3.3			
47	45.5	44.6	44.2	43.8	3.1	3.3	3.4	3.5			
52	48.6	47.7	47.2	46.8	3.1	3.3	3.4	3.5			
57	51.7	50.7	50.2	49.8	3.2	3.4	3.5	3.6			
62	54.8	53.8	53.2	52.8	3.3	3.5	3.6	3.7			
67	57.9	56.8	56.3	55.8	3.3	3.5	3.7	3.8			
72	61.0	59.9	59.3	58.8	3.4	3.6	3.7	3.8			

ARI RATING FOR HEATING					
CFM	CAPACITY 47	COP 47	CAPACITY 17	COP 17	HSPF
1580	44500	4.00	26200	2.70	9.00

ARI Standard Capacity Rating Conditions

ARI STANDARD 210/240 RATING CONDITIONS — (A) Cooling 80°F DB, 67°F WB air entering indoor coil, 95°F DB air entering outdoor coil. (B) High Temperature Heating 47°F DB, 43°F WB air entering outdoor coil, 70°F DB air entering indoor coil. (C) Low Temperature Heating 17°F DB, 15°F WB air entering outdoor coil, 70°F DB air entering indoor coil. (D) Rated indoor airflow for heating is the same as for cooling.

Performance Data Heating

LOW STAGE: 4WCZ6048A AT 1200 NOM CFM (HEATING PERFORMANCE AT INDOOR DRY BULB TEMPERATURE)

OD AMB	TOTAL CAPACITY MBH				TOTAL POWER IN KILOWATTS				USE THE FOLLOWING FACTORS TO COMPENSATE FOR DIFFERENT AIR FLOW					
	60	70	75	80	60	70	75	80	AIR FLOW RATE, CFM	CAPACITY MULTIPLIER	TOTAL POWER MULTIPLIER			
22	20.0	19.7	19.5	19.3	2.1	2.2	2.3	2.3	LOW	1050	0.987	0.975		
27	21.7	21.3	21.1	20.9	2.1	2.3	2.3	2.4	HIGH	1350	1.011	1.025		
32	23.4	23.0	22.7	22.5	2.2	2.3	2.4	2.4						
37	25.7	25.2	25.0	24.7	2.2	2.3	2.4	2.4						
42	29.0	28.4	28.1	27.9	2.2	2.3	2.4	2.4						
47	32.2	31.6	31.3	31.0	2.2	2.3	2.4	2.4						
52	34.5	33.9	33.5	33.2	2.2	2.3	2.4	2.5						
57	36.8	36.2	35.8	35.5	2.2	2.3	2.4	2.5						
62	39.2	38.4	38.0	37.7	2.2	2.4	2.4	2.5						
67	41.5	40.7	40.3	39.9	2.2	2.4	2.5	2.5						
72	43.8	43.0	42.5	42.1	2.3	2.4	2.5	2.6						

ARI RATING FOR HEATING					
CFM	CAPACITY 47	COP 47	CAPACITY 17	COP 17	HSPF
1175	31496	4.02	17947	2.42	9.00

ARI Standard Capacity Rating Conditions
 ARI STANDARD 210/240 RATING CONDITIONS — (A) Cooling 80°F DB, 67°F WB air entering indoor coil, 95°F DB air entering outdoor coil. (B) High Temperature Heating 47°F DB, 43°F WB air entering outdoor coil, 70°F DB air entering indoor coil. (C) Low Temperature Heating 17°F DB, 15°F WB air entering outdoor coil, 70°F DB air entering indoor coil. (D) Rated indoor airflow for heating is the same as for cooling.

HIGH STAGE: 4WCZ6060A AT 2000 NOM CFM (HEATING PERFORMANCE AT INDOOR DRY BULB TEMPERATURE)

OD AMB	TOTAL CAPACITY MBH				TOTAL POWER IN KILOWATTS				USE THE FOLLOWING FACTORS TO COMPENSATE FOR DIFFERENT AIR FLOW					
	60	70	75	80	60	70	75	80	AIR FLOW RATE, CFM	CAPACITY MULTIPLIER	TOTAL POWER MULTIPLIER			
2	23.9	23.4	23.2	23.0	3.4	3.6	3.7	3.9	LOW	1750	0.987	0.975		
7	27.5	27.0	26.7	26.5	3.5	3.7	3.8	3.9	HIGH	2250	1.011	1.025		
12	31.2	30.6	30.3	30.0	3.6	3.8	3.9	4.0						
17	34.8	34.1	33.8	33.5	3.6	3.9	4.0	4.1						
22	35.2	34.6	34.2	33.9	3.6	3.8	4.0	4.1						
27	35.7	35.0	34.7	34.4	3.6	3.8	4.0	4.1						
32	36.1	35.5	35.1	34.8	3.6	3.8	3.9	4.1						
37	39.8	39.0	38.7	38.3	3.7	3.9	4.0	4.1						
42	48.2	47.3	46.8	46.4	3.8	4.1	4.2	4.3						
47	56.6	55.6	55.0	54.5	4.0	4.3	4.4	4.5						
52	60.2	59.1	58.5	58.0	4.1	4.4	4.5	4.6						
57	63.9	62.7	62.1	61.5	4.2	4.4	4.6	4.7						
62	67.5	66.3	65.6	65.0	4.2	4.5	4.6	4.8						
67	71.2	69.8	69.1	68.5	4.3	4.6	4.7	4.8						
72	74.8	73.4	72.7	72.0	4.4	4.6	4.8	4.9						

ARI RATING FOR HEATING					
CFM	CAPACITY 47	COP 47	CAPACITY 17	COP 17	HSPF
1895	55000	3.80	33800	2.60	8.60

ARI Standard Capacity Rating Conditions
 ARI STANDARD 210/240 RATING CONDITIONS — (A) Cooling 80°F DB, 67°F WB air entering indoor coil, 95°F DB air entering outdoor coil. (B) High Temperature Heating 47°F DB, 43°F WB air entering outdoor coil, 70°F DB air entering indoor coil. (C) Low Temperature Heating 17°F DB, 15°F WB air entering outdoor coil, 70°F DB air entering indoor coil. (D) Rated indoor airflow for heating is the same as for cooling.

LOW STAGE: 4WCZ6060A AT 1500 NOM CFM (HEATING PERFORMANCE AT INDOOR DRY BULB TEMPERATURE)

OD AMB	TOTAL CAPACITY MBH				TOTAL POWER IN KILOWATTS				USE THE FOLLOWING FACTORS TO COMPENSATE FOR DIFFERENT AIR FLOW					
	60	70	75	80	60	70	75	80	AIR FLOW RATE, CFM	CAPACITY MULTIPLIER	TOTAL POWER MULTIPLIER			
22	24.5	24.0	23.8	23.6	2.6	2.7	2.8	2.9	LOW	1325	0.987	0.975		
27	26.2	25.7	25.5	25.2	2.6	2.8	2.9	2.9	HIGH	1700	1.011	1.025		
32	27.9	27.4	27.1	26.9	2.7	2.8	2.9	3.0						
37	30.6	30.0	29.7	29.4	2.7	2.9	2.9	3.0						
42	34.6	33.9	33.6	33.3	2.7	2.9	3.0	3.0						
47	38.6	37.9	37.5	37.2	2.7	2.9	3.0	3.1						
52	41.2	40.5	40.1	39.7	2.7	2.9	3.0	3.1						
57	43.9	43.1	42.6	42.3	2.8	3.0	3.0	3.1						
62	46.5	45.7	45.2	44.8	2.8	3.0	3.1	3.2						
67	49.2	48.3	47.8	47.3	2.8	3.0	3.1	3.2						
72	51.8	50.9	50.3	49.9	2.9	3.1	3.2	3.2						

ARI RATING FOR HEATING					
CFM	CAPACITY 47	COP 47	CAPACITY 17	COP 17	HSPF
1320	36972	3.81	21784	2.43	8.60

ARI Standard Capacity Rating Conditions
 ARI STANDARD 210/240 RATING CONDITIONS — (A) Cooling 80°F DB, 67°F WB air entering indoor coil, 95°F DB air entering outdoor coil. (B) High Temperature Heating 47°F DB, 43°F WB air entering outdoor coil, 70°F DB air entering indoor coil. (C) Low Temperature Heating 17°F DB, 15°F WB air entering outdoor coil, 70°F DB air entering indoor coil. (D) Rated indoor airflow for heating is the same as for cooling.

Indoor Blower Performance

Indoor Fan Performance 4WCZ6036A

Horizontal		External Static Pressure (in. wg)										
		0	0.1	0.2	0.3	0.4	0.5	0.6	0.7	0.8	0.9	1
350 CFM/Ton Setting	Low	-	741	743	744	744	743	742	740	737	-	-
	High	-	1059	1062	1063	1063	1062	1059	1057	1053	-	-
400 CFM/Ton Setting	Low	-	825	837	843	844	844	842	839	836	-	-
	High	-	1179	1196	1204	1206	1205	1203	1199	1194	-	-
450 CFM/Ton Setting	Low	-	976	964	959	957	953	949	945	945	-	-
	High	-	1394	1377	1371	1367	1362	1355	1350	1350	-	-

Down Flow		External Static Pressure (in. wg)										
		0	0.1	0.2	0.3	0.4	0.5	0.6	0.7	0.8	0.9	1
350 CFM/Ton Setting	Low	-	722	745	747	744	742	743	744	736	-	-
	High	-	1032	1064	1068	1063	1060	1062	1063	1052	-	-
400 CFM/Ton Setting	Low	-	830	841	842	840	839	838	836	828	-	-
	High	-	1186	1201	1203	1201	1198	1197	1194	1184	-	-
450 CFM/Ton Setting	Low	-	978	965	964	963	958	948	941	949	-	-
	High	-	1397	1378	1377	1376	1368	1354	1344	1356	-	-

Indoor Fan Performance 4WCZ6048A

Horizontal		External Static Pressure (in. wg)										
		0.0	0.1	0.2	0.3	0.4	0.5	0.6	0.7	0.8	0.9	1.0
350 CFM/Ton Setting	Low	-	954	973	977	973	966	957	950	944	-	-
	High	-	1363	1390	1396	1390	1379	1368	1358	1349	-	-
400 CFM/Ton Setting	Low	-	1121	1106	1104	1106	1108	1108	1104	1097	-	-
	High	-	1601	1580	1577	1580	1583	1583	1577	1567	-	-
450 CFM/Ton Setting	Low	-	1223	1254	1268	1271	1268	1264	1261	1258	-	-
	High	-	1747	1792	1811	1816	1812	1806	1801	1797	-	-

Down Flow		External Static Pressure (in. wg)										
		0.0	0.1	0.2	0.3	0.4	0.5	0.6	0.7	0.8	0.9	1.0
350 CFM/Ton Setting	Low	-	948	977	977	970	969	975	979	962	-	-
	High	-	1354	1396	1396	1386	1384	1393	1399	1375	-	-
400 CFM/Ton Setting	Low	-	1102	1106	1109	1113	1116	1119	1120	1118	-	-
	High	-	1574	1580	1585	1589	1594	1599	1601	1597	-	-
450 CFM/Ton Setting	Low	-	1295	1277	1272	1273	1274	1273	1272	1273	-	-
	High	-	1851	1824	1817	1818	1820	1819	1817	1819	-	-

Indoor Fan Performance 4WCZ6060A

Horizontal		External Static Pressure (in. wg)										
		0.0	0.1	0.2	0.3	0.4	0.5	0.6	0.7	0.8	0.9	1.0
350 CFM/Ton Setting	Low	-	1163	1238	1259	1256	1246	1240	1237	1230	-	-
	High	-	1662	1768	1799	1794	1780	1771	1767	1757	-	-
400 CFM/Ton Setting	Low	-	1443	1427	1422	1422	1423	1422	1418	1410	-	-
	High	-	2062	2038	2031	2032	2034	2032	2025	2015	-	-

Down Flow		External Static Pressure (in. wg)										
		0.0	0.1	0.2	0.3	0.4	0.5	0.6	0.7	0.8	0.9	1.0
350 CFM/Ton Setting	Low	-	1259	1219	1208	1207	1206	1199	1188	1185	-	-
	High	-	1799	1742	1726	1725	1723	1712	1698	1692	-	-
400 CFM/Ton Setting	Low	-	1410	1393	1386	1384	1383	1380	1368	1344	-	-
	High	-	2015	1990	1980	1977	1976	1971	1955	1920	-	-

Indoor Blower Performance

4WCZ6036 AIRFLOW WITH AUXILIARY HEAT (CFM)

SWITCH SETTINGS		SELECTION	NOMINAL AIRFLOW
7-OFF	8-OFF	LOW	1050 CFM
7-ON	8-OFF	HIGH	1200 CFM
7-OFF	8-ON	HIGH	1200 CFM
7-ON	8-ON	HIGH	1200 CFM

4WCZ6048 AIRFLOW WITH AUXILIARY HEAT (CFM)

SWITCH SETTINGS		SELECTION	NOMINAL AIRFLOW
7-OFF	8-OFF	LOW	1400 CFM
7-ON	8-OFF	HIGH	1600 CFM
7-OFF	8-ON	HIGH	1600 CFM
7-ON	8-ON	HIGH	1600 CFM

4WCZ6060 AIRFLOW WITH AUXILIARY HEAT (CFM)

SWITCH SETTINGS		SELECTION	NOMINAL AIRFLOW
7-OFF	8-OFF	LOW	1400 CFM
7-ON	8-OFF	HIGH	1600 CFM
7-OFF	8-ON	HIGH	1600 CFM
7-ON	8-ON	HIGH	1600 CFM

COOLING FAN DELAY OPTIONS

SWITCH SETTINGS		DELAY	NOMINAL AIRFLOW
5-OFF	6-OFF	NONE	100%
5-ON	6-OFF	45 SEC	100%
5-OFF	6-ON	90 SEC	50%
5-ON	6-ON	**	50-100%

** This ENHANCED MODE selection provides a ramping up and ramping down of the indoor blower speed to provide improved comfort, quietness, and potential energy savings. The Graph below shows the ramping process

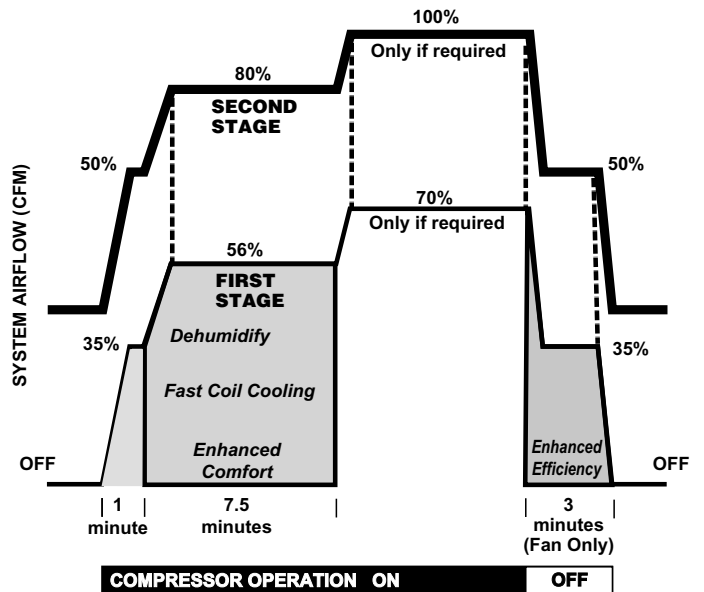

Typical Wiring

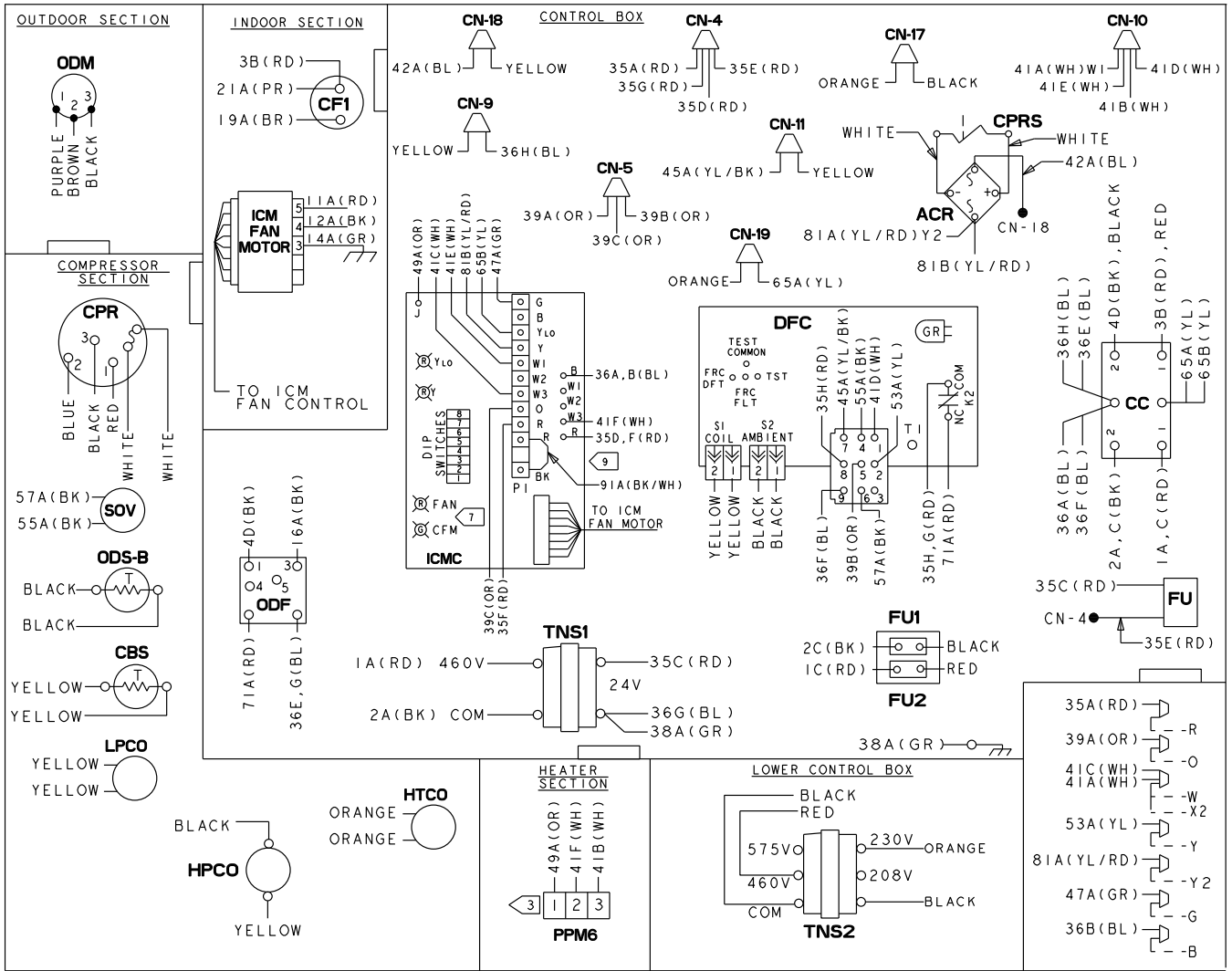

NOTES:

- 1 CONNECTIONS SHOWN ARE FOR A TYPICAL THERMOSTAT. SEE SCHEMATIC SUPPLIED WITH THERMOSTAT FOR PROPER CONNECTIONS. LOW VOLTAGE WIRING TO UNIT MAY BE NEC CLASS 2 AND MUST BE A MIN. OF 18 A.W.G.
- 2 MAXIMUM ADDITIONAL EXTERNAL LOAD (PILOT DUTY) BETWEEN "B" AND "R" OF 0.5 AMPS, 24 VAC IS AVAILABLE WHEN A HEATER IS INSTALLED.
- 3 SEE WIRING DIAGRAM WITH HEATER FOR DETAILS OF HEATER WIRING.
- 4 IF ANY OF THE ORIGINAL WIRE AS SUPPLIED IN THIS UNIT MUST BE REPLACED, REPLACE IT WITH APPLIANCE WIRING MATERIAL RATED AT 105°C.
- 5 "T" TERMINAL IS NOT CONNECTED WHEN AN ELECTRONIC THERMOSTAT IS USED.
- 7 THE GREEN LED ON THE ICMC BOARD FLASHES ONCE PER HUNDRED CFM.
- 8 WHEN MECHANICAL THERMOSTATS ARE USED, DO NOT CONNECT THE "W" LEAD AT THERMOSTAT.
- 9 IF OPTIONAL HUMIDISTAT ACCESSORY IS USED, ON THE ICMC BOARD CUT THE 91A(BK/WH) JUMPER AND CONNECT THE HUMIDISTAT BETWEEN TERMINALS.

NOTE
THREE PHASE MOTOR(S) FACTORY SUPPLIED IN THIS EQUIPMENT, PROTECTED UNDER PRIMARY SINGLE-PHASE CONDITIONS

ABBR	COLOR	ABBR	COLOR
BK	BLACK	PR	PURPLE
BL	BLUE	RD	RED
BR	BROWN	WH	WHITE
GR	GREEN	YL	YELLOW
OR	ORANGE		

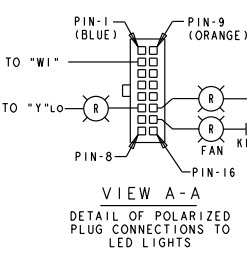

D757684P01

ICMC DIP SWITCH SETTINGS

DIP SWITCH SETTINGS				COOLING/ HEAT PUMP CFM	NOMINAL AIRFLOW
SW 1	SW 2	SW 3	SW 4		
OFF	OFF	OFF	ON	350 CFM/TON	
OFF	OFF	OFF	OFF	400 CFM/TON	**
OFF	OFF	ON	OFF	450 CFM/TON	
FAN OFF-DELAY OPTIONS					
SW 5	SW 6			NONE	NOMINAL
OFF	OFF			45 SECONDS	100% NOMINAL**
OFF	ON			90 SECONDS	50% NOMINAL
ON	ON			ENHANCED	ENHANCED
ELECTRIC HEAT AIRFLOW					
SW 7	SW 8			350 CFM/TON	
OFF	OFF			400 CFM/TON	**
ON	OFF				

** FACTORY SETTING.
AT CONTINUOUS FAN SETTING ("G" ONLY) AIRFLOW VALUES ARE APPROXIMATELY 50% OF LISTED VALUE.
THE HEAT PUMP FAN OFF-DELAY IS THE SAME AS THE COOLING MODE.

DEVICE	DESCRIPTION	LINE
AH, BH	CONTACTOR ELECTRIC HEAT	39, 40
CBS	COIL BOTTOM SENSOR	31
CC	COMPRESSOR CONTACTOR COIL	41
CN	CONNECTOR OR WIRE NUT	
CPR	COMPRESSOR	11
DFC	DEFROST CONTROL	26-36
FU	FUSE	25
ICM	INTEGRATED COMMUTATED MOTOR	20
IOL	INTERNAL OVERLOAD	
ODM	OUTDOOR FAN MOTOR	16
ODS	OUTDOOR AMBIENT SENSOR	33
ICMC	INTEGRATED COMMUTATED MOTOR CONTROL	45-51
PPM6	HEATER PLUG (FEMALE)	39, 40
SOV	SWITCHOVER VALVE	36
TNS1	CONTROL POWER TRANSFORMER	24
LPCO	LOW PRESSURE SWITCH	46
HPCO	HIGH PRESSURE SWITCH	41
TNS2	460V/230V AUTO TRANSFORMER	19
CPRS	COMPRESSOR SOLENOID	43
FUI, FU2	FUSE, AUTO TRANSFORMER	18, 19
CF1	OUTDOOR FAN CAPACITOR	15
HTCO	HIGH TEMPERATURE SWITCH	41
ACR	RECTIFIER BRIDGE	45

Typical Wiring

MODELS
4WCZ6048A4
4WCZ6060A4

⚠ WARNING
 HAZARDOUS VOLTAGE!
 DISCONNECT ALL ELECTRIC POWER INCLUDING REMOTE DISCONNECTS BEFORE SERVICING.
 FAILURE TO DISCONNECT POWER SUPPLY BEFORE SERVICING CAN CAUSE SEVERE PERSONAL INJURY OR DEATH.

⚠ AVERTISSEMENT
 VOLTAGE HASARDEUX!
 DECONNECTEZ TOUTES LES SOURCES ELECTRIQUES INCLUANT LES DISJONCTEURS SITUES A DISTANCE AVANT D'EFFECTUER L'ENTRETIEN. FAUTE DE DECONNECTER LA SOURCE ELECTRIQUE AVANT D'EFFECTUER L'ENTRETIEN PEUT ENTRAINDER DES BLESSURES CORPORELLES SEVERES OU LA MORT.

⚠ CAUTION
 USE COPPER CONDUCTORS ONLY!
 UNIT TERMINALS ARE NOT DESIGNED TO ACCEPT OTHER TYPES OF CONDUCTORS.

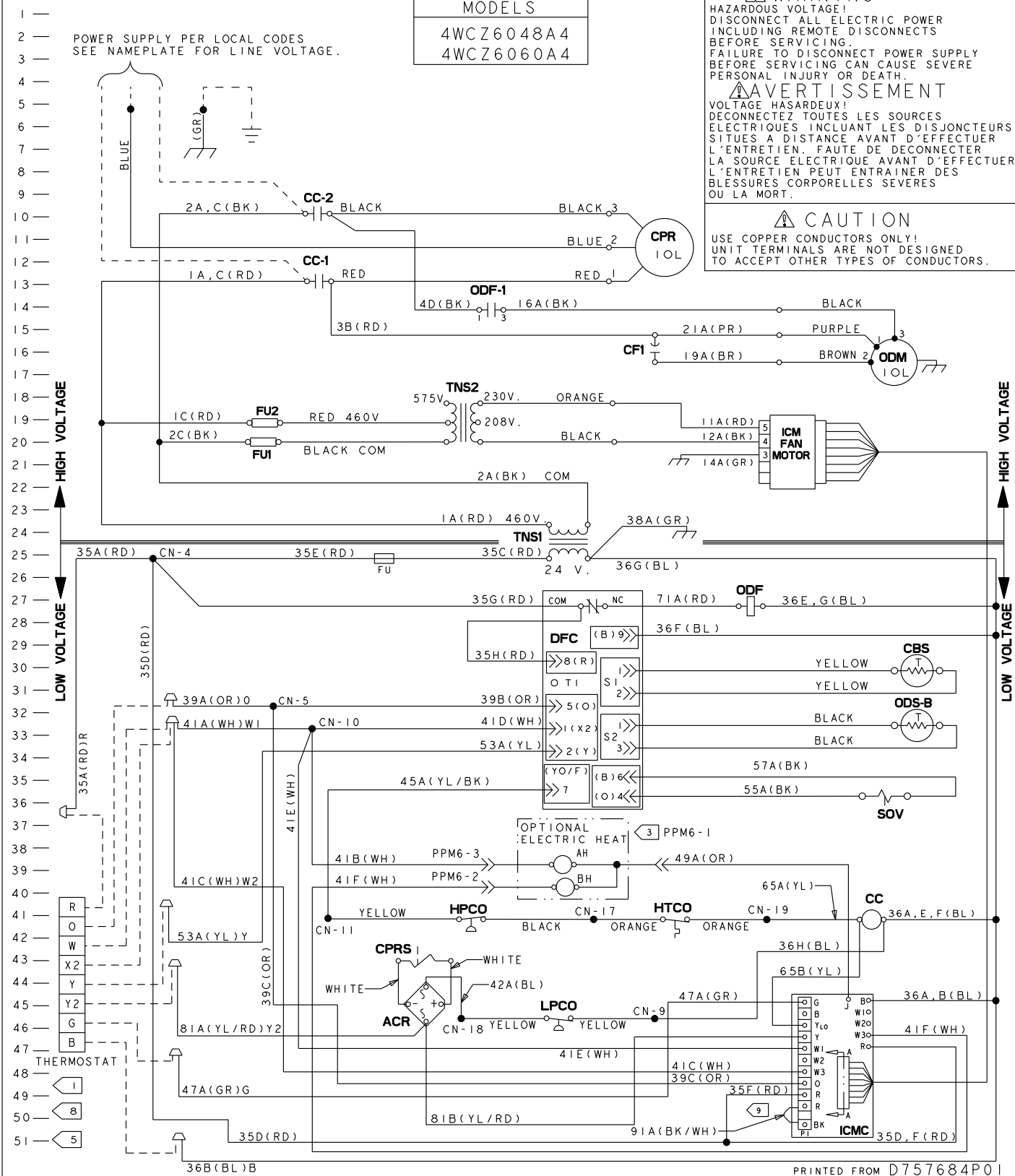

Optional Equipment

BAYCURB050A FULL PERIMETER ROOF MOUNTING CURB FOR 4WCZ6036A

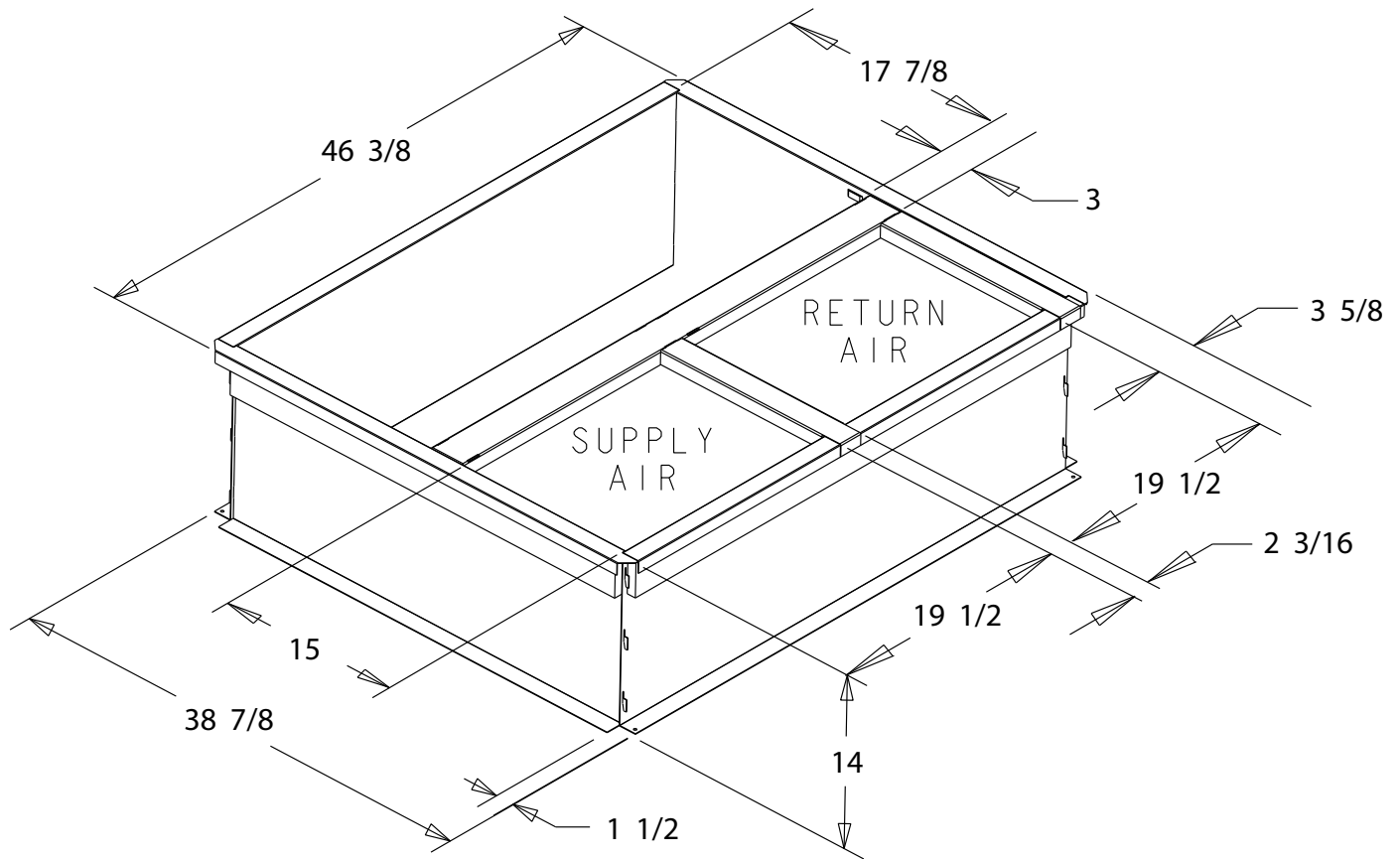

The drawings on this page are prepared by the manufacturer in order to provide detail regarding job layout only. These drawings are not intended to be used as a basis to construct, build or modify the items depicted in the drawings. The manufacturer is not responsible for the unauthorized use of these drawings and expressly disclaims any liability for damages resulting from such unauthorized use.

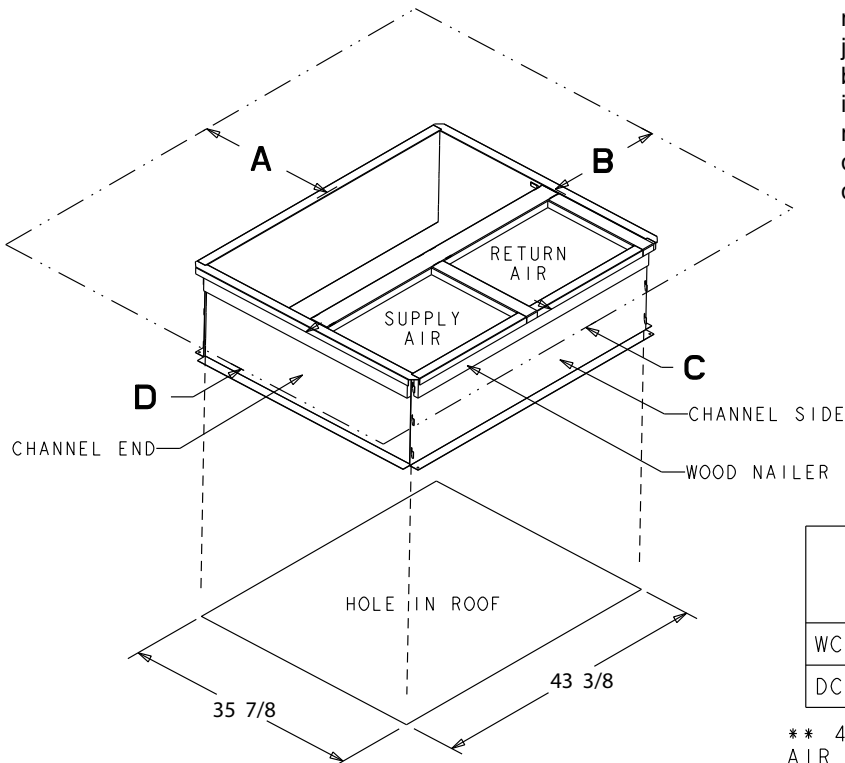

	SERVICE CLEARANCE DIMENSIONS			
	A	B	C	D
WC*/TC*	42.00	36.00	12.00**	24.00
DC*/YC*	42.00	36.00	12.00**	36.00

** 42.00 WITH ECONOMIZER WITH 25% FRESH AIR ACCESSORY

Optional Equipment

BAYCURB051A Full Perimeter Roof Mounting Curb for 4WCZ6048-060A

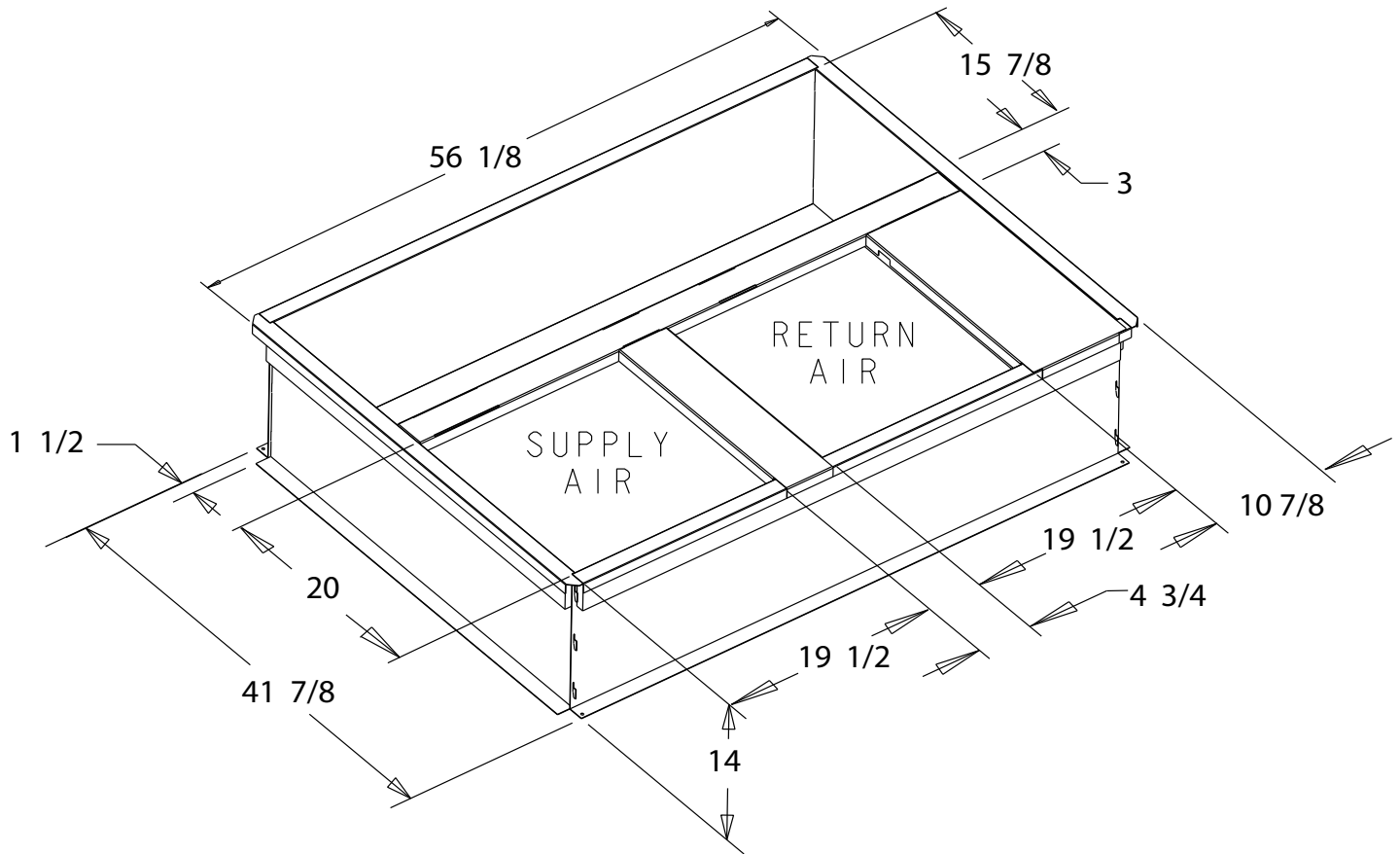

The drawings on this page are prepared by the manufacturer in order to provide detail regarding job layout only. These drawings are not intended to be used as a basis to construct, build or modify the items depicted in the drawings. The manufacturer is not responsible for the unauthorized use of these drawings and expressly disclaims any liability for damages resulting from such unauthorized use.

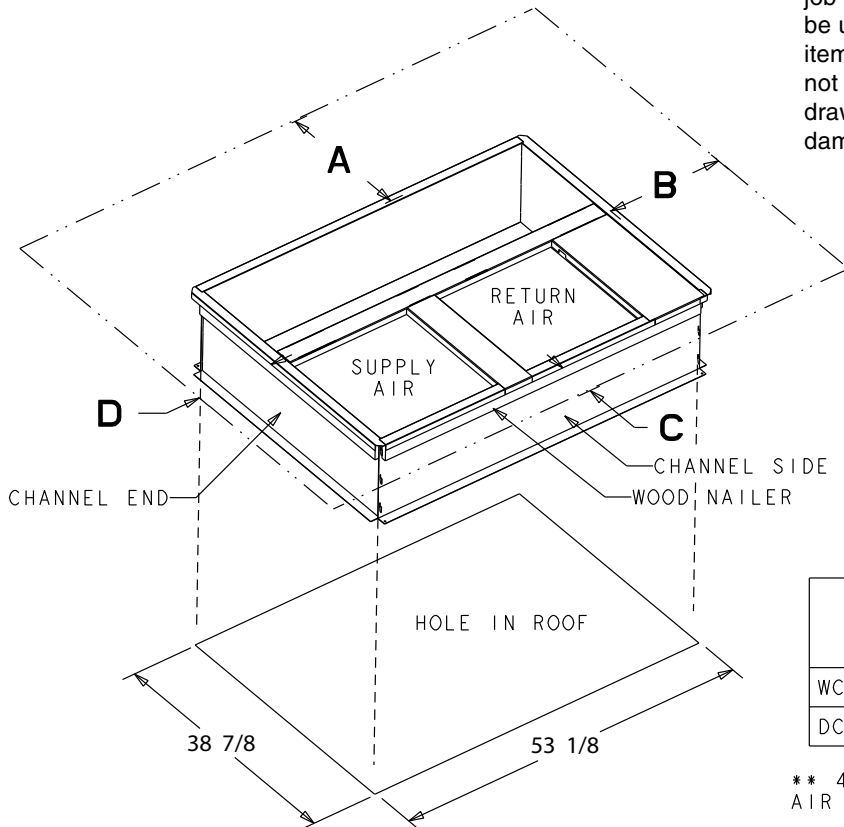

	SERVICE CLEARANCE DIMENSIONS			
	A	B	C	D
WC*/TC*	42.00	36.00	12.00**	24.00
DC*/YC*	42.00	36.00	12.00**	36.00

** 42.00 WITH ECONOMIZER WITH 25% FRESH AIR ACCESSORY

Optional Equipment

BAYFLTR101, 201B, 1" - 2" Filter Rack (Mounts in Filter/Coil Section)

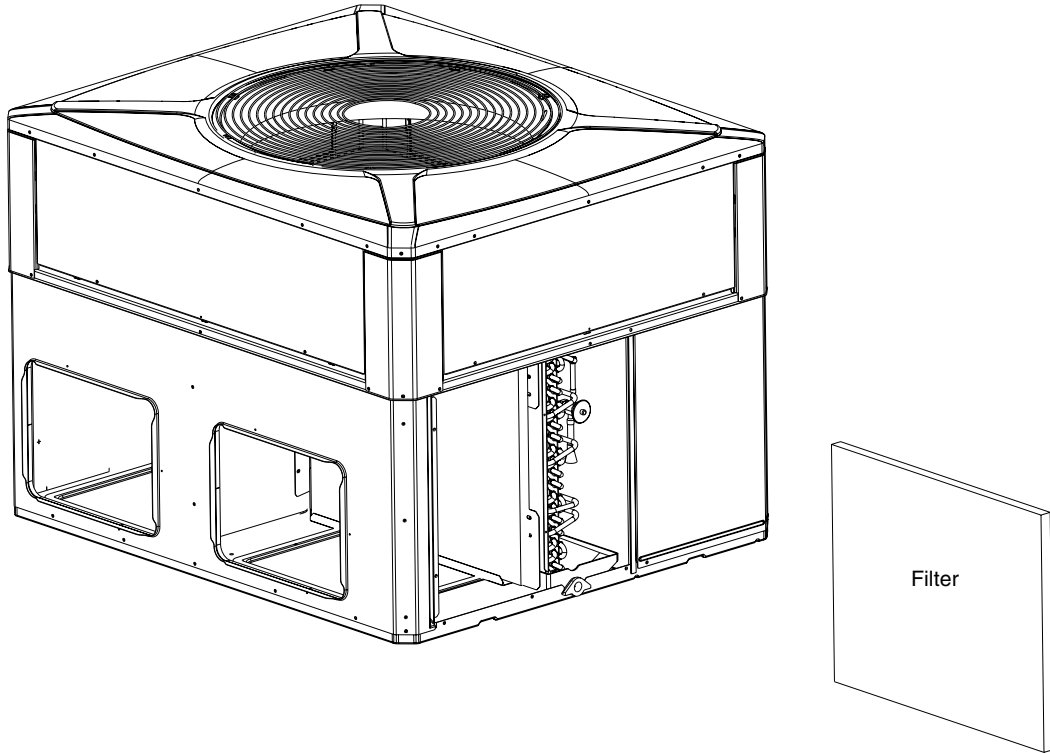

BAYACCDOR1A & BAYACCDOR2A Hinged Filter Access Door Replaces Filter/Coil Access Panel

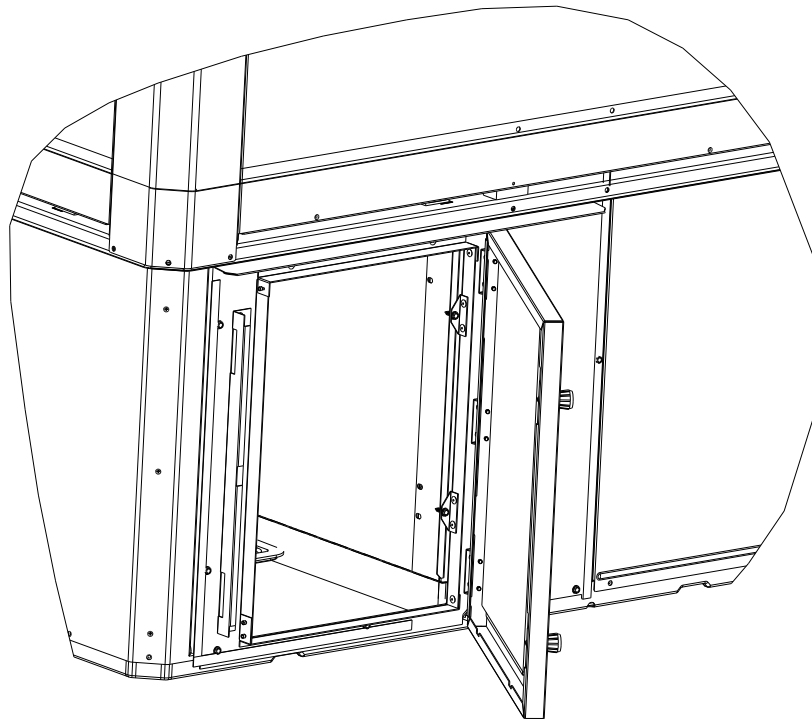

The drawings on this page are prepared by the manufacturer in order to provide detail regarding job layout only. These drawings are not intended to be used as a basis to construct, build or modify the items depicted in the drawings. The manufacturer is not responsible for the unauthorized use of these drawings and expressly disclaims any liability for damages resulting from such unauthorized use.

Optional Equipment

BAYECON103,104A Down Discharge Economizer and Rain Hood (Mounts Over Horizontal Return Air Opening)

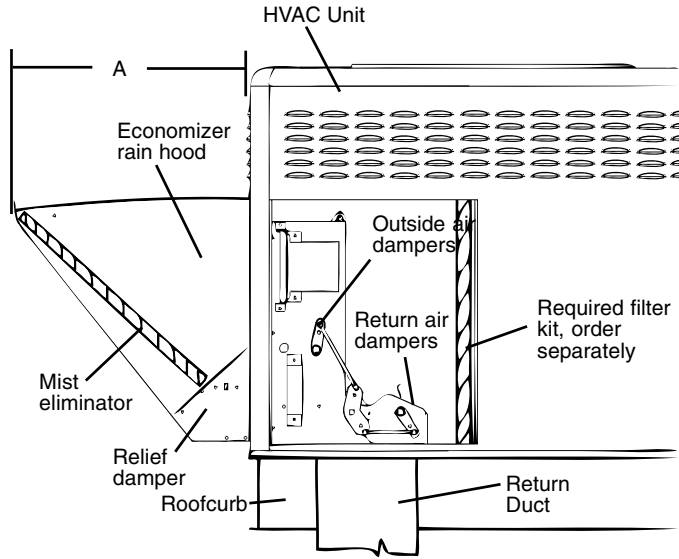

Economizer	Models	A
BAYECON103A	4WCZ6036A 4DCZ6036A 4YCZ6036A	20 1/8"
BAYECON104A	4WCZ6048-060A 4DCZ6048-060A 4YCZ6048-060A	24 3/8"

BAYCON203,204A Horizontal Economizer and Rain Hood

The drawings on this page are prepared by the manufacturer in order to provide detail regarding job layout only. These drawings are not intended to be used as a basis to construct, build or modify the items depicted in the drawings. The manufacturer is not responsible for the unauthorized use of these drawings and expressly disclaims any liability for damages resulting from such unauthorized use.

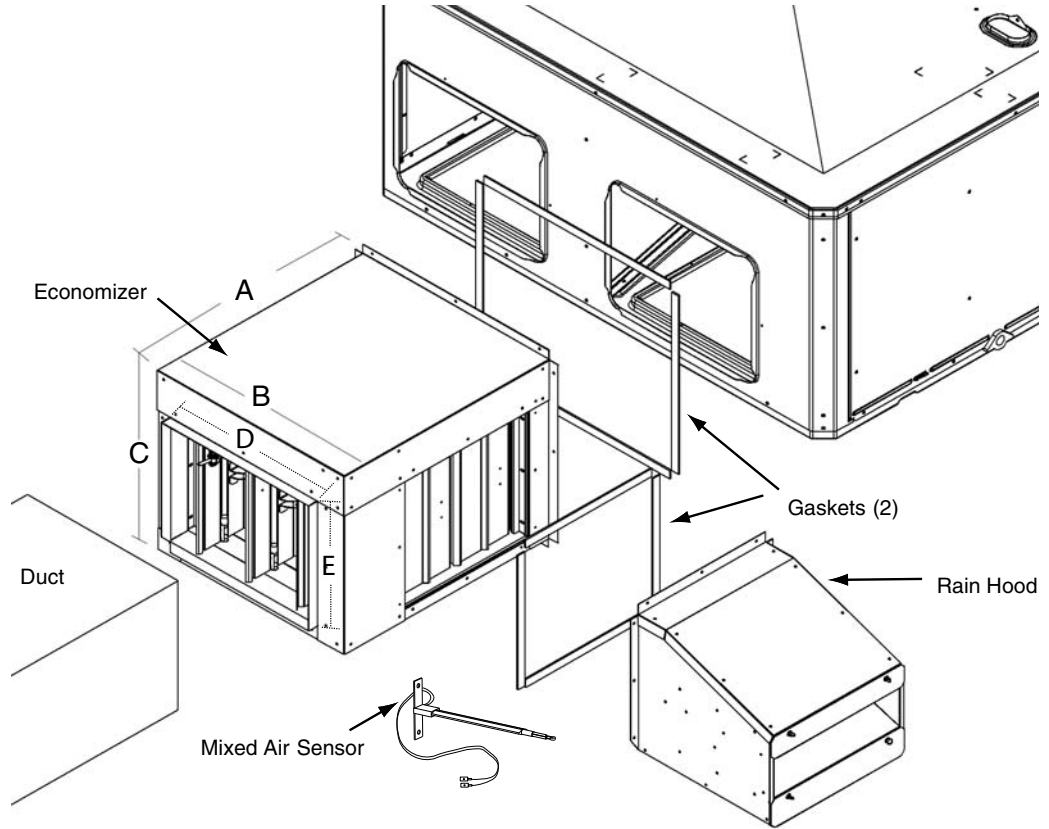

Economizer	A	B	C	D	E
BAYECON203AA	22"	20"	16 7/8"	15 11/16"	11 11/16"
BAYECON204AA	24"	22 21/32"	19"	17 11/16"	14 11/16"

Optional Equipment

BAYOSAH001,002A, 25% Outside Air Damper (Replaces Filter/Coil Access Panel)

The drawings on this page are prepared by the manufacturer in order to provide detail regarding job layout only. These drawings are not intended to be used as a basis to construct, build or modify the items depicted in the drawings. The manufacturer is not responsible for the unauthorized use of these drawings and expressly disclaims any liability for damages resulting from such unauthorized use.

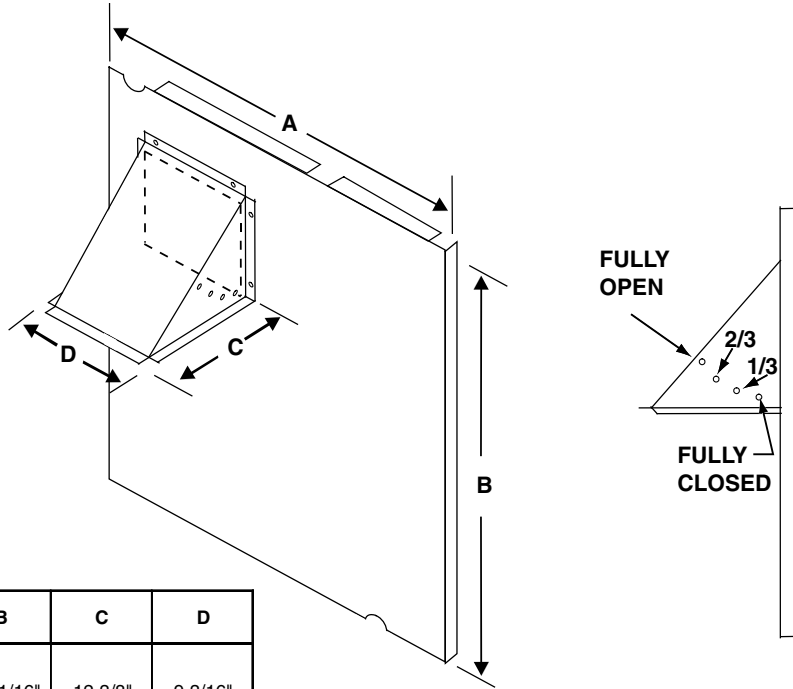

Manual Fresh Air Model	Unit Application Models	A	B	C	D
BAYOSAH001	2/4YC,WC3018-036A 4TC*3018-036A 4W/T/Y/DCY4024-036A 4W/Y/DCZ6036A	22 7/16"	20 11/16"	12 3/8"	9 3/16"
BAYOSAH002	2/4YC,WC3042-060A 4TC*3042-060A 4W/T/Y/DCY4042-060 4W/Y/DCZ6048-060A	25 3/16"	20 11/16"	12 3/8"	9 3/16"

BAYDMPR101,102A, 25% Motorized Outside Air Damper (Mounts Over Horizontal Return Air Opening)

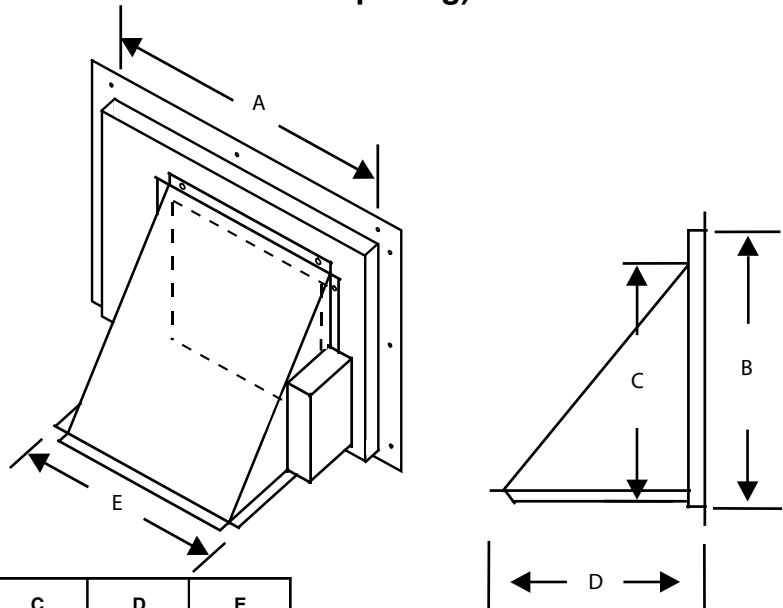

	Unit Application Models	A	B	C	D	E
BAYDMPR101A	2/4YC,WC3018-036A 4TC3018-036A 4W/T/Y/DCY4024-036A 4W/Y/DCZ6036A	15 13/16"	11 13/16"	10 1/4"	11 1/2"	12 1/4"
BAYDMPR102A	2/4YC,WC3042-060A 4TC3042-060A 4W/T/Y/DCY4042-060A 4W/Y/DCZ6048-060A	18 3/16"	15 1/8"	10 1/4"	11 1/2"	12 1/4"

Dimensional Data and Weights

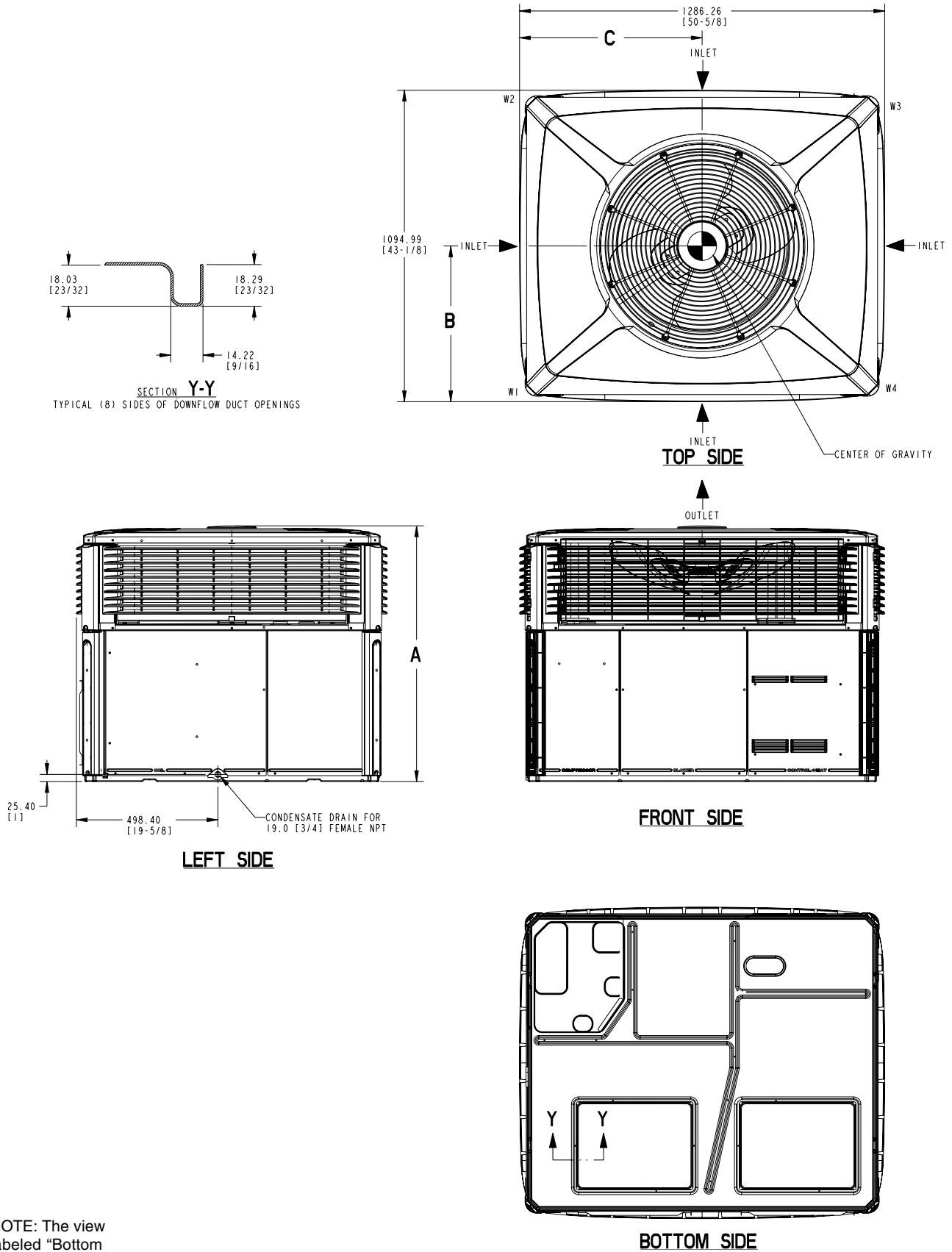

NOTE: The view labeled "Bottom Side" represents the Base as viewed looking up from underneath the unit.

Figure 1. WCZ6036A (1 of 3)

Dimensional Data and Weights

RECOMMENDED SERVICE CLEARANCE MM/IN.		
		WITH ECONOMIZER
BACK SIDE	304.8 [12]	762.0 [30]
LEFT SIDE	762.0 [30]	914.4 [36]
RIGHT SIDE	609.6 [24]	-
FRONT SIDE	1066.8 [42]	-

CLEARANCE TO COMBUSTIBLE MATERIAL MM/IN.	
BOTTOM	0
BACK SIDE	25.4 [1]
LEFT SIDE	152.4 [6]
RIGHT SIDE	152.4 [6]
FRONT SIDE	304.8 [12]
TOP	914.4 [36]

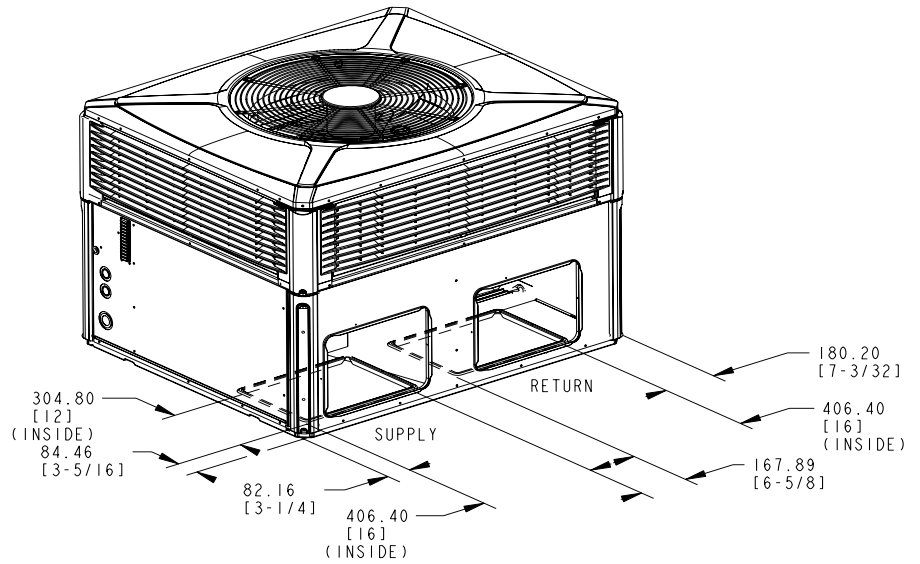

BOTTOM DUCT OPENINGS

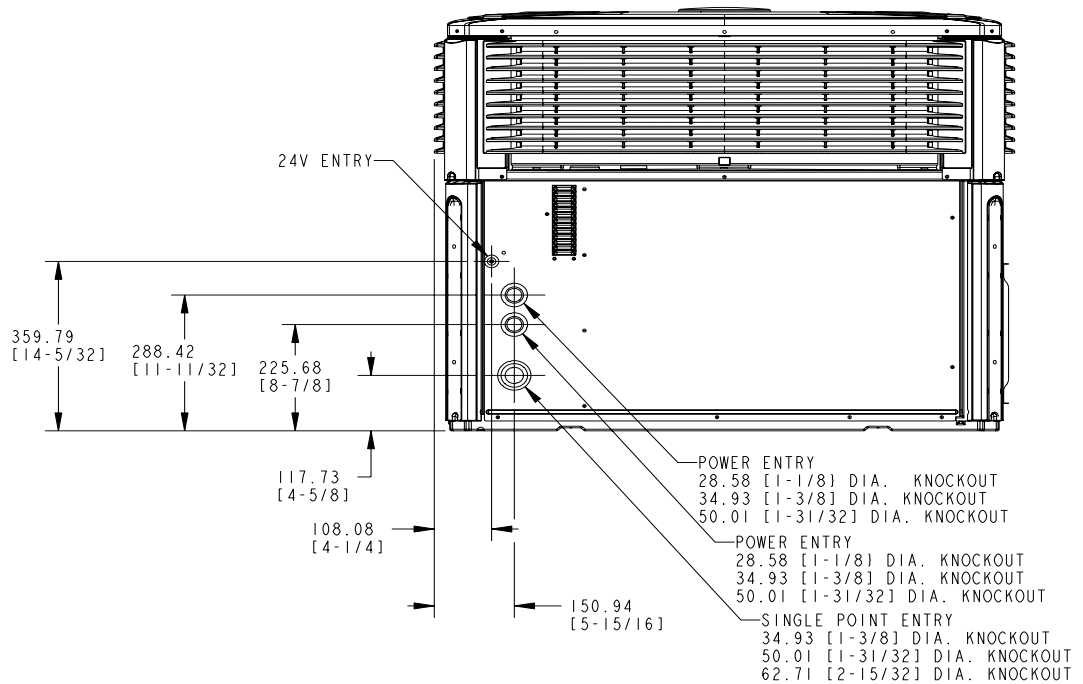

RIGHT SIDE

Figure 2. WCZ6036A (2 of 3)

Dimensional Data and Weights

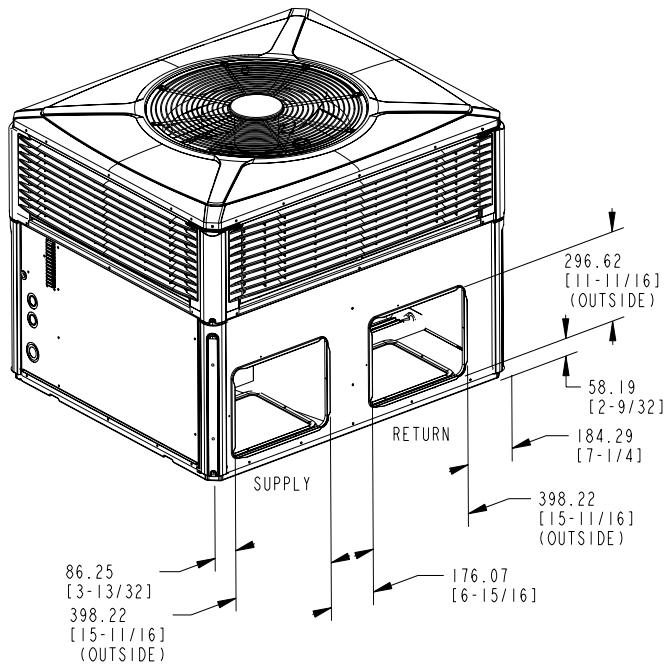

BACK DUCT OPENINGS

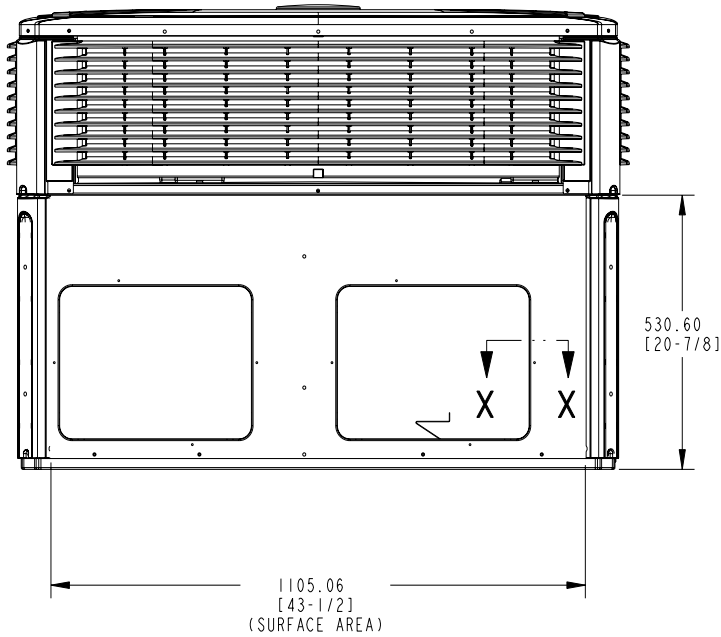

BACK SIDE

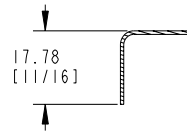

SECTION X-X
TYPICAL (8) SIDES OF SIDEFLOW DUCT OPENINGS

MODEL	HEIGHT MM/IN.	APPROX. CORNER WEIGHT - KG/LBS				TOTAL UNIT WEIGHT KG/LBS	CENTER OF GRAVITY MM/IN.	
	A	W1	W2	W3	W4		B	C
4TCY4024	898.53 [35-3/8]	56.7 [125]	35.8 [79]	25.4 [56]	39.9 [88]	157.9 [348]	401.3 [15.8]	508.0 [20.0]
4TCY4036	949.33 [37-3/8]	57.6 [127]	36.3 [80]	25.9 [57]	40.8 [90]	160.6 [354]	401.3 [15.8]	508.0 [20.0]
4WCY4024	898.53 [35-3/8]	57.6 [127]	36.3 [80]	26.3 [58]	41.7 [92]	161.9 [357]	401.3 [15.8]	515.6 [20.3]
4WCY4036	949.33 [37-3/8]	60.8 [134]	38.1 [84]	27.2 [60]	42.6 [94]	168.7 [372]	401.3 [15.8]	508.0 [20.0]
4WCZ6036	949.33 [37-3/8]	60.8 [134]	38.1 [84]	27.2 [60]	42.6 [94]	168.7 [372]	401.3 [15.8]	508.0 [20.0]

Figure 3. WCZ6036A (3 of 3)

Dimensional Data and Weights

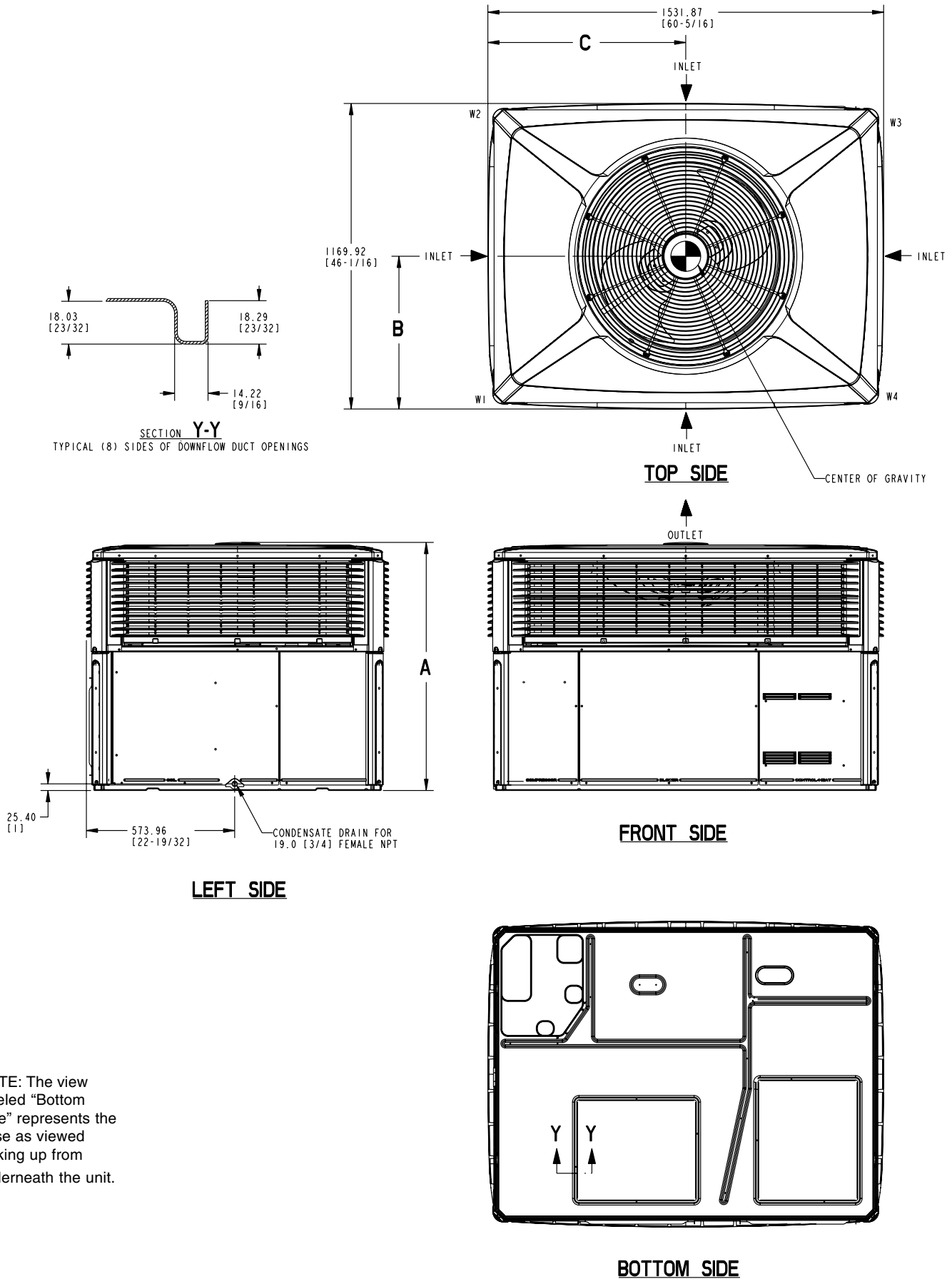

NOTE: The view labeled "Bottom Side" represents the Base as viewed looking up from underneath the unit.

Figure 4. WCZ6048A through WCZ6060A (1 of 3)

Dimensional Data and Weight

RECOMMENDED SERVICE CLEARANCE MM/IN.		
		WITH ECONOMIZER
BACK SIDE	304.8 [12]	762.0 [30]
LEFT SIDE	914.4 [36]	1066.8 [42]
RIGHT SIDE	609.6 [24]	-
FRONT SIDE	762.0 [30]	-

CLEARANCE TO COMBUSTIBLE MATERIAL MM/IN.	
BOTTOM	0
BACK SIDE	25.4 [1]
LEFT SIDE	152.4 [6]
RIGHT SIDE	152.4 [6]
FRONT SIDE	304.8 [12]
TOP	914.4 [36]

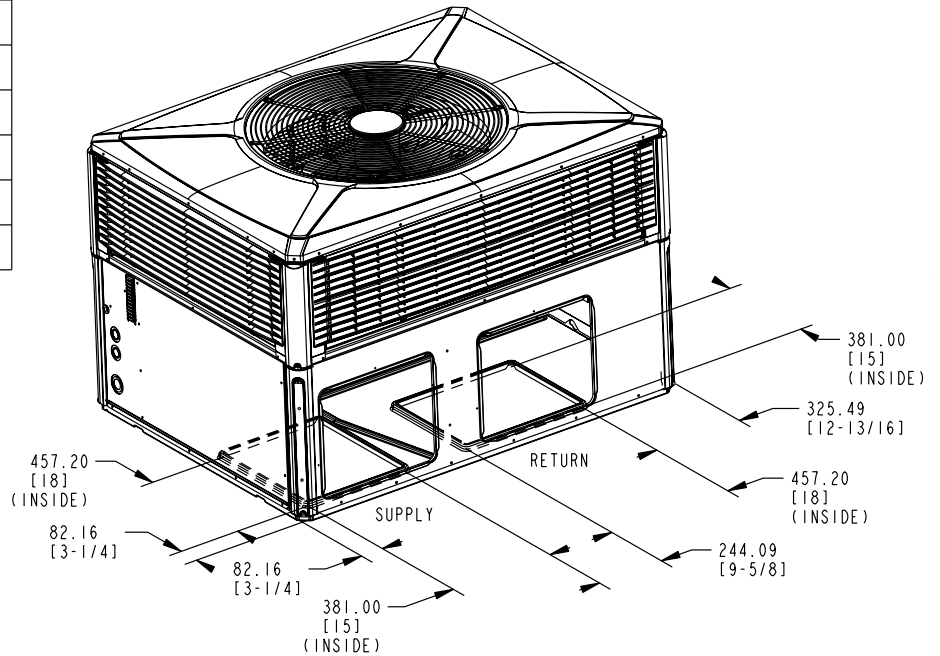

BOTTOM DUCT OPENINGS

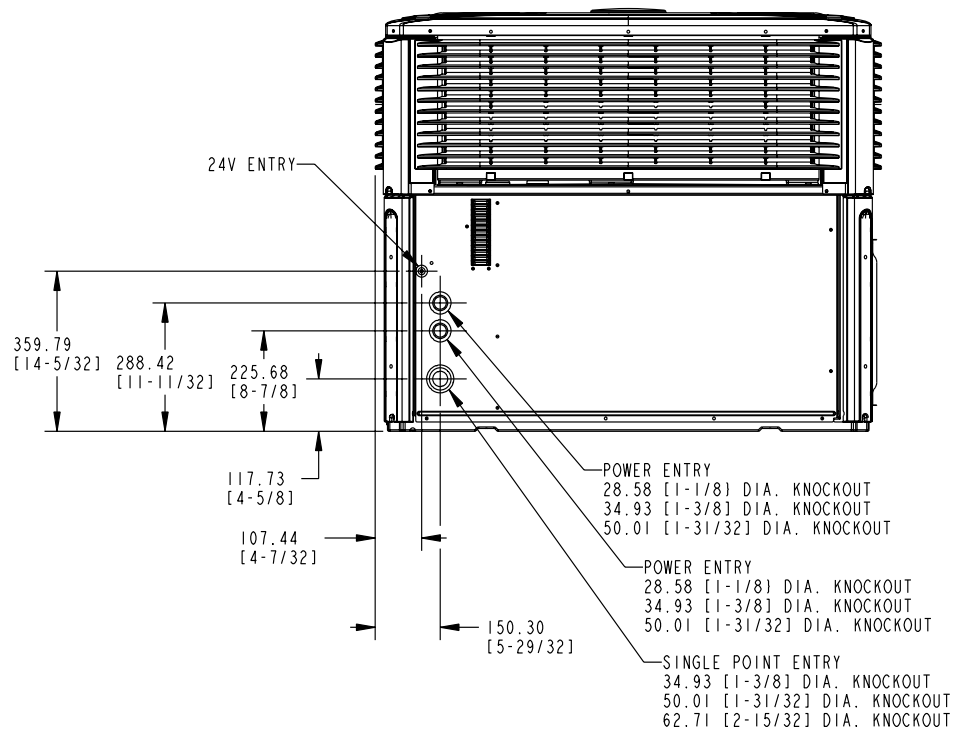
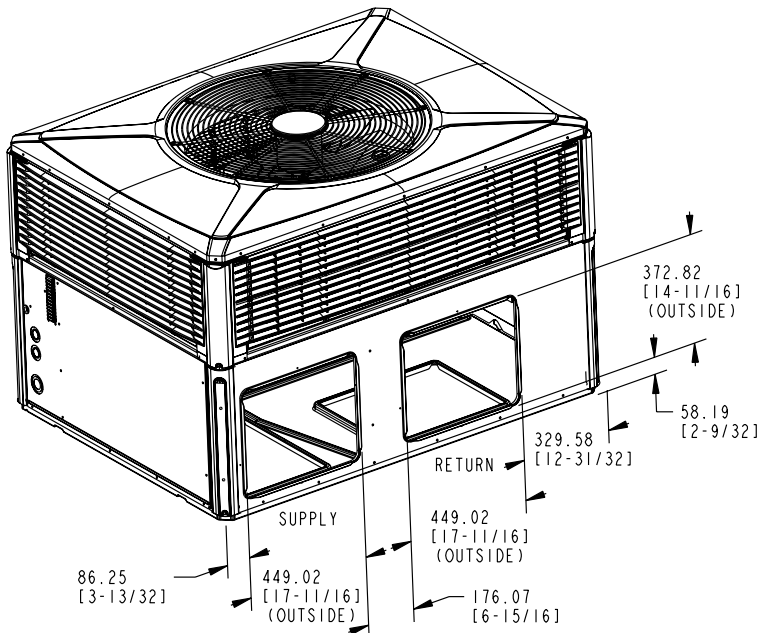
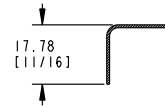

Figure 5. WCZ6048A through WCZ6060A (2 of 3)

Dimensional Data and Weight



BACK DUCT OPENINGS



SECTION X-X
TYPICAL (8) SIDES OF SIDEFLOW DUCT OPENINGS

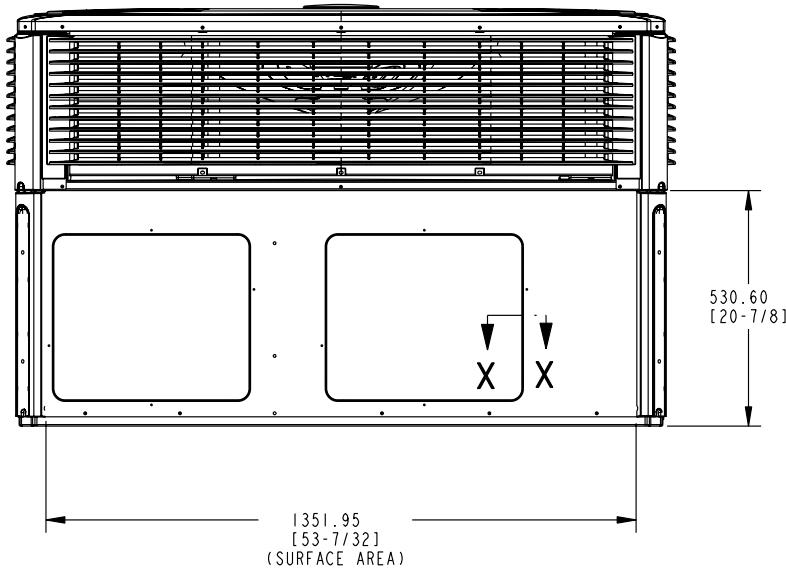

BACK SIDE

MODEL	HEIGHT MM/IN.	APPROX. CORNER WEIGHT - KG/LBS				SHIPPING WEIGHT KG/LBS	TOTAL UNIT WEIGHT KG/LBS	CENTER OF GRAVITY MM/IN.	
	A	W1	W2	W3	W4			B	C
4TCY4048	949.33 [37-3/8]	76.2 [168]	47.6 [105]	35.8 [79]	57.6 [127]	275.6 (607)	217.3 [479]	426.7 [16.8]	635.0 [25.0]
4TCY4060	1050.93 [41-3/8]	78.9 [174]	46.7 [103]	34.9 [77]	59.1 [130]	277.8 (612)	219.5 [484]	414.0 [16.3]	635.0 [25.0]
4WCY4048	949.33 [37-3/8]	68.9 [152]	40.8 [90]	30.8 [68]	52.2 [115]	275.6 (607)	217.5 [479]	414.0 [16.3]	635.0 [25.0]
4WCY4060	1050.93 [41-3/8]	80.3 [177]	47.6 [105]	35.8 [79]	60.8 [134]	282.8 (623)	224.5 [495]	414.0 [16.3]	635.0 [25.0]
4WCZ6048	1050.93 [41-3/8]	68.9 [152]	40.8 [90]	30.8 [68]	52.2 [115]	275.6 (607)	217.5 [479]	414.0 [16.3]	635.0 [25.0]
4WCZ6060	1050.93 [41-3/8]	80.3 [177]	47.6 [105]	35.8 [79]	60.8 [134]	282.8 (623)	224.5 [495]	414.0 [16.3]	635.0 [25.0]

Figure 6. WCZ6048A through WCZ6060A (3 of 3)

Mechanical Specifications

General

The units shall be horizontal airflow as shipped and convertible to downflow. All units shall be factory assembled, piped, internally wired and fully charged with refrigerant. Units shall be UL listed and carry a UL label. All units shall be factory run tested to check cooling operation, fan and blower rotation and control or TXV sequence. Units shall be designed to operate at ambient temperatures between 115°F and 55°F in cooling as manufactured. Cooling performance shall be rated in accordance with ARI standards.

Unit Casing

All components shall be mounted in a weather-resistant steel cabinet with an enamel finish. Access panels shall be provided for unit controls and indoor coil and fans. Indoor air section compartment shall be completely insulated with fireproof, permanent, odorless glass fiber material. Knockouts shall be provided for utility and control connections. Drain connections shall be provided to accommodate indoor water runoff.

Compressor

The compressor shall be hermetically sealed, high efficiency Climatuff® two-stage compressors. Internal overcurrent and over temperature protection, internal pressure relief shall be standard.

Refrigeration System

All units shall have TXV in cooling and TXV in heating. Service pressure tap ports, and a refrigerant line filter dryer shall be standard.

Indoor Coil

Coils shall be internally finned or smooth bore 3/8" copper tubes mechanically bonded to configured aluminum plate fin as standard. Evaporator coil leak and pressure tested to 200 psig; condenser coil tested to 450 psig.

Condenser Coil —

The Spine Fin™ condenser coil shall be continuously wrapped, corrosion resistant all aluminum with minimum brazed joints. This coil is 3/8 inch O.D. seamless aluminum tubing glued to a continuous aluminum fin. Coils are lab tested to withstand 2,000 pounds of pressure per square inch. The outdoor coil provides low airflow resistance and efficient heat transfer. The coil is protected on all four sides by louvered panels.

Indoor Air Fan — Direct-drive, forward-curved, centrifugal wheel in a Composite Vortica® Blower housing. Motor shall have thermal overload protection. Permanently lubricated motor bearings. Motor/blower assembly isolated from unit with rubber mounts.

Condenser Fan — Direct-drive, draw thru propeller type. Weather-proofed permanent split capacitor fan motor shall have built-in thermal overload and permanently lubricated motor bearings.

System Controls

System controls include condenser fan, evaporator fan and compressor contactors.

Accessories

Roof Curb — The roof curb shall be designed to mate with the unit and provide support and complete weathertight installation when properly installed. Adhesive back polyurethane sealing strips shall be provided to ensure an airtight seal between supply and return openings of the curb and unit. The roof curb design allows field fabricated ductwork to be connected directly to the curb. Curb ships knocked down for field assembly, and includes factory-installed wood nailer strips.

Electric Heaters — Each heater assembly shall include power supply fusing if over 48 amps, automatic resetting limit switches and heat limiters for thermal protection. Heaters shall be provided with polarized plugs for quick connection to unit low voltage wiring. Electric heat modules shall be UL listed.

Single Source Power Entry — This accessory when used with electric heat accessory shall allow single source power connection to unit and heater combination. Single source power entry kits shall have specific matching heater(s). Kit shall include high voltage terminal blocks, fuse blocks and fuses, cut-to-length interconnecting wiring, and junction box (if required) to provide power sources with fuse protection as required for both the unit and accessory heater. Kit components shall install within the unit cabinet in the heater access section. Single source branch power circuit shall be protected and wired in accordance with local codes.

Fully Modulating Economizer — This accessory shall be field installed and be composed of the following items: 0-100% fresh air damper, damper drive motor, fixed dry bulb enthalpy control, and low voltage wiring plug for electrical connections. Solid state enthalpy or differential enthalpy control is optional. Economizer operations shall be controlled by the preset position of the enthalpy control. A barometric relief damper shall be standard with the economizer and provide a pressure operated damper that shall be gravity closing and prohibit entrance of outside air on equipment "off" cycle. Economizer requires BAYRLAY004A relay kit to interface the economizer to the heat pump.

Manual Outside Air Dampers — Rain hood and screen shall be field installed. Suitable for up to 25% outside air.

Start Kit — Extra compressor starting capacity for single phase equipment.

Control Options

Standard Indoor Thermostats — Two stage heating/cooling or one stage heating/cooling thermostats shall be available in either manual or automatic changeover.

Programmable Electronic Night Setback Thermostat — Programmable electronic thermostat shall provide heating setback and cooling setup with 7-day, programming capability. 1H/1C or 2H/2C models available.



Trane
6200 Troup Highway
Tyler, TX 75707-9010

The manufacturer has a policy of continuous product and product data improvement and it reserves the right to change design and specifications without notice.