

ARPF SERIES

MULTI-POSITION AIR HANDLER

THREE-SPEED, 1½- TO 5-TON UNITS WITH PAINTED CABINET

Standard Features

- Suitable for use with refrigerants R-410A and R-22
- Check flowrate expansion device
- Direct-drive, multi-speed motor
- Transformer and blower time-delay on all units
- Complies with the Factory-sealed Air Handling Credit with or without field-installed filter kits as listed in the 2001 Florida Building Code, Chapter 13, Section 610.2.A.2.1
- AHRI Certified; ETL Listed

Cabinet Features

- Fully insulated, painted steel cabinet with attractive Architectural Gray finish
- Built-in coil has horizontal, vertical, and downflow drain pans with secondary drain connections
- Built-in filter rack for 1" filter (filter not included)
- Power supply entry at top; low-voltage entry on top and both sides
- Factory-sealed to achieve 2% or less leakage rate with or without field-installed filter kits at 1.0" water gauge external duct static pressure



Contents

Nomenclature	2
Product Specifications	3
Dimensions	4
Airflow Data	5
Wiring Diagram	6
Accessories	7



* Complete warranty details available from your local dealer or at www.amana-hac.com. To receive the 10-Year Parts Limited Warranty, online registration must be completed within 60 days of installation. Online registration is not required in California or Québec.

NOMENCLATURE

	A	R	P	F	3642	1	6	AA	
	1	2	3	4	5,6,7,8	9	10	11,12	
Brand	A Single-piece Air Handler								Engineering * Major/ Minor Revisions * Not used for inventory management
Unit Application	C Ceiling Mount PSC Motor D Downflow PSC Motor E Multi-Position Variable-Speed Motor R Multi-Position PSC Motor S Multi-Position EEM Motor W Wall Mount PSC Motor								Refrigerant Charge No Digit = R-22 only 6 = R-410A or R-22
Cabinet Finish	U Unpainted P Painted N Uncased								Electrical 1 208/240 V, 1 Phase, 60 Hz
Expansion Device	F Flowrater T Expansion Valve								Nominal Capacity Range @ 13 SEER
									Multi-Position & Downflow Applications 1729 1½ to 2½ Tons (for Export Systems) 1830 1½-3½ Tons 3642 3-3½ Tons
									Ceiling Mount & Wall Mount Applications (Nominal Cooling Capacity/ Electric Heat kW) 1805 1½ Tons Cooling/ 5 kW Electric Heat 2405 2 Tons Cooling/ 5 kW Electric Heat 3608 3 Tons Cooling/ 8 kW Electric Heat



SPECIFICATIONS

	ARPF 182416*	ARPF 193116*	ARPF 303016*	ARPF 363616*
NOMINAL RATINGS				
Cooling (Btu/h)	18,000 - 24,000	18,000 - 30,000	30,000	36,000
CFM (High/ Med/ Low)	1,025/ 790/ 570	1,025/ 780/ 545	1,330/ 1,230/ 980	1,230/ 1,140/ 955
BLOWER				
Diameter	9½"	9½"	9½"	9½"
Width	6"	6"	8"	6"
Coil Drain Connect FPT	¾"	¾"	¾"	¾"
SERVICE VALVE				
Liquid Line	¾"	¾"	¾"	¾"
Suction Line	¾"	⅞"	¾"	¾"
ELECTRICAL DATA				
Voltage	208/240	208/240	208/240	208/240
Min Circuit Ampacity	2.1/2.1	1.9/1.9	3.3/3.3	3.3/3.3
Max. Overcurrent Device (amps)	15 / 15	15 / 15	15 / 15	15/15
Min./ Max VAC	197/ 253	197/ 253	197/ 253	197/ 253
Blower Motor FLA/ HP	1.7/ ⅓	1.48/ ¼	2.64/ ⅓	2.64/ ⅓
SHIP WEIGHT (LBS)	116	155	144	164

	ARPF 364216*	ARPF 374316*	ARPF 486016*	ARPF 496116*
NOMINAL RATINGS				
Cooling (Btu/h)	36,000 - 42,000	36,000 - 42,000	48,000 - 60,000	48,000 - 60,000
CFM (High/ Med/ Low)	1625 / 1400 / 1250	1,925/ 1,550/ 1,345	1,985/ 1,875/ 1,650	1,915/ 1,795/ 1,585
BLOWER				
Diameter	10⅝"	11 15/16"	10⅝"	10⅝"
Width	8"	10 ⅞"	10⅝"	10⅝"
Coil Drain Connect FPT	¾"	¾"	¾"	¾"
SERVICE VALVE				
Liquid Line	¾"	¾"	¾"	¾"
Suction Line	¾"	¾"	¾"	¾"
ELECTRICAL DATA				
Voltage	208/240	208/240	208/240	208/240
Min Circuit Ampacity	3.7/3.7	4.2/4.2	5.4/5.4	5.4/5.4
Max. Overcurrent Device (amps)	15 / 15	15 / 15	15 / 15	15/15
Min./ Max VAC	197/ 253	197/ 253	197/ 253	197/ 253
Blower Motor FLA/ HP	2.95/ ½	3.39/ ½	4.3/ ¾	4.3/ ¾
SHIP WEIGHT (LBS)	160	195	183	192

DIMENSIONS

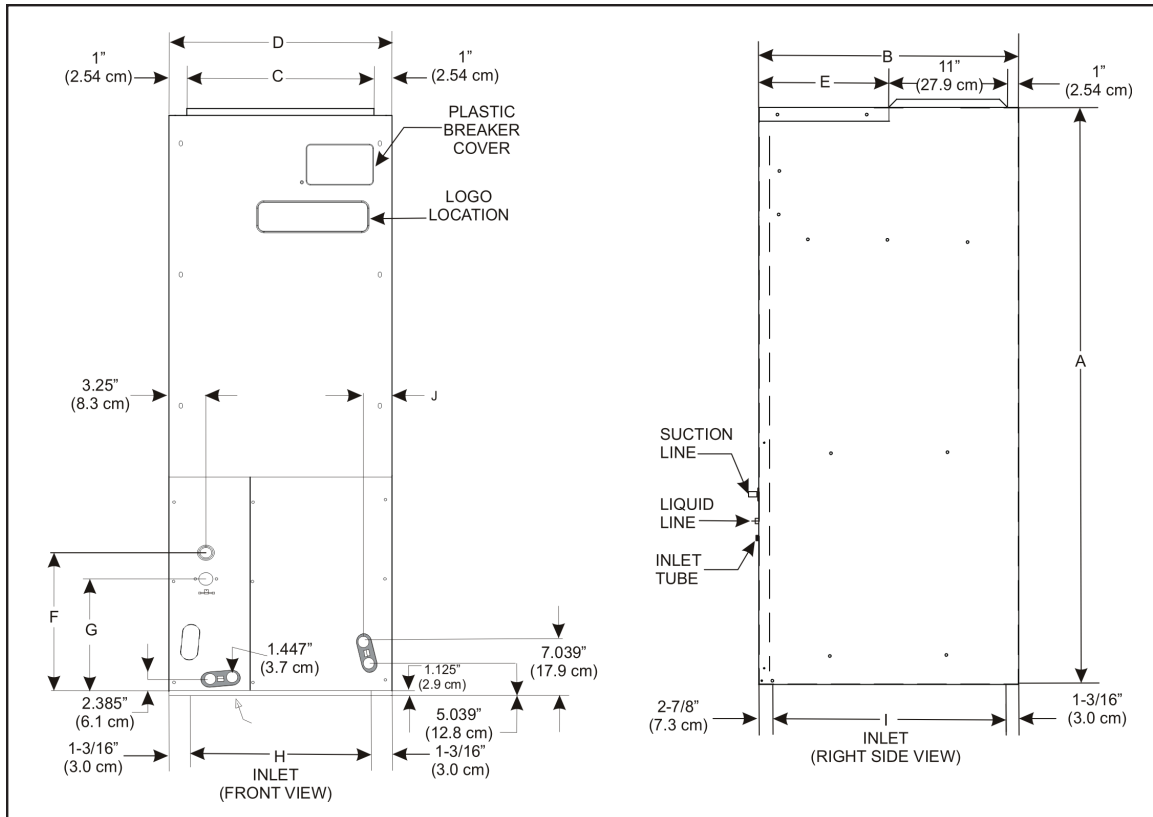

MODEL	A	B	C	D	E	F	G	H	I	J
ARPF182416*	42 ¹ / ₈ "	22"	13 ¹ / ₂ "	15 ¹ / ₂ "	10"	14 ¹ / ₂ "	11 ¹⁵ / ₁₆ "	13 ³ / ₈ "	17 ¹⁵ / ₁₆ "	2"
ARPF193116*	46 ³ / ₄ "	22"	17 ¹ / ₂ "	19 ¹ / ₂ "	10"	14 ¹ / ₂ "	11 ¹⁵ / ₁₆ "	17 ⁷ / ₈ "	17 ¹⁵ / ₁₆ "	2"
ARPF303016*	46 ³ / ₄ "	22"	17 ¹ / ₂ "	19 ¹ / ₂ "	10"	14 ¹ / ₂ "	11 ¹⁵ / ₁₆ "	17 ⁷ / ₈ "	17 ¹⁵ / ₁₆ "	2"
ARPF363616*	46 ³ / ₄ "	22"	17 ¹ / ₂ "	19 ¹ / ₂ "	10"	14 ¹ / ₂ "	11 ¹⁵ / ₁₆ "	17 ⁷ / ₈ "	17 ¹⁵ / ₁₆ "	1 ⁴ / ₅ "
ARPF364216*	53 ³ / ₄ "	24"	20"	22"	12"	14 ¹ / ₂ "	11 ¹⁵ / ₁₆ "	19 ³ / ₈ "	19 ¹⁵ / ₁₆ "	1 ⁴ / ₅ "
ARPF374316*	53 ³ / ₄ "	24"	20"	22"	12"	14 ¹ / ₂ "	11 ¹⁵ / ₁₆ "	19 ³ / ₈ "	19 ¹⁵ / ₁₆ "	1 ⁴ / ₅ "
ARPF486016*	53 ³ / ₄ "	24"	20"	22"	12"	14 ¹ / ₂ "	11 ¹⁵ / ₁₆ "	19 ³ / ₈ "	19 ¹⁵ / ₁₆ "	1 ⁴ / ₅ "
ARPF496116*	53 ³ / ₄ "	24"	20"	22"	12"	14 ¹ / ₂ "	11 ¹⁵ / ₁₆ "	19 ³ / ₈ "	19 ¹⁵ / ₁₆ "	1 ⁴ / ₅ "

AIRFLOW DATA

MODEL	CFM DELIVERED AGAINST EXTERNAL STATIC PRESSURE					
	SPEED	0.1"	0.2"	0.3"	0.4"	0.5"
ARPF182416*	High	1,155	1,090	1,025	950	895
	Med.	940	890	860	815	755
	Low	695	665	650	610	550
ARPF193116*	High	1,135	1,085	1,025	965	915
	Med.	860	825	780	750	680
	Low	600	570	545	500	465
ARPF303016*	High	1,385	1,315	1,240	1,155	1,065
	Med.	1,340	1,290	1,230	1,140	1,050
	Low	1,075	1,030	980	910	840
ARPF363616*	High	1,310	1,240	1,155	1,090	1,020
	Med.	1,270	1,210	1,140	1,075	980
	Low	1,045	1,005	955	885	805
ARPF364216*	High	1,700	1,660	1,625	1,545	1,505
	Med.	1,500	1,440	1,400	1,350	1,345
	Low	1,370	1,300	1,250	1,230	1,220
ARPF374316*	High	2,065	2,000	1,925	1,860	1,780
	Med.	1,685	1,635	1,550	1,470	1,410
	Low	1,490	1,425	1,345	1,280	1,205
ARPF486016*	High	2,150	2,120	2,070	2,000	1,940
	Med.	1,940	1,930	1,905	1,860	1,790
	Low	1,610	1,600	1,590	1,575	1,550
ARPF496116*	High	2,150	2,105	2,040	1,970	1,880
	Med.	1,960	1,935	1,895	1,825	1,750
	Low	1,670	1,625	1,585	1,525	1,455

Note: Assumes dry coil with filter in place; SCFM correction for wet coil = 4% (208V / 240V)

HEAT KIT MATCH-UPS

HEAT KITS	ARPF 182416	ARPF 193116	ARPF 303016	ARPF 363616	ARPF 364216	ARPF 374316	ARPF 486016	ARPF 496116*
HKR-03*	X	X	X	X	X	X	X	X
HKR-05*, HKR-05C*	X	X	X	X	X	X	X	X
HKR-06*	X	X	X	X	X	X	X	X
HKR-08*, HKR-08C*	X ¹	X ¹	X	X	X	X	X	X
HKR-10*, HKR-10C*	X ¹	X ¹	X ¹	X	X	X	X	X
HKR-15C*	X ²	X ²	X ²	X ²	X ³	X ³	X	X
HKR-20C*			X ²		X ³	X ³	X	X
HKR-21C*			X ²		X ³	X ³	X	X
^ HKR3-15*			X ²	X ²	X ³	X ³	X	X
^ HKR3-20*			X ²		X ³	X ³	X	X

* Revision level that may or may not be designated

C Circuit breaker option

^ Heat kit requires three-phase power supply

¹ Air handler must either be on medium or high speed

² Air handler must be on high speed

³ For static pressure of 0.6 or higher, air handler must be on medium or high speed

SINGLE POINT KIT **

MODEL	HKR-15C	HKR-20C	HKR-21C
SPW-01	X	X	X

** Must be installed along with any of the above compatible heat kits. This kit will fit any ARPF air handler as long as a compatible heat kit is installed in the unit.

WIRING DIAGRAM

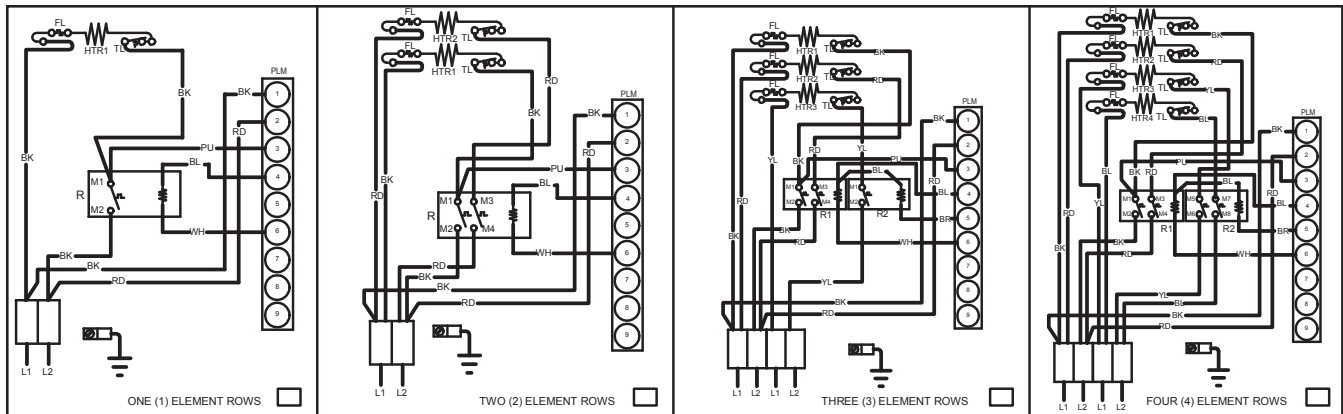

NOTE: WHEN INSTALLING HEATER KIT, ENSURE SPEED TAP DOES NOT EXCEED MINIMUM BLOWER SPEED (MBS) SPECIFIED FOR THE AIRHANDLER/HEATER KIT COMBINATION ON THIS UNIT'S S&R PLATE. AFTER INSTALLING OPTIONAL HEAT KIT, MARK A "X" IN THE PROVIDED ABOVE. MARK ACCORDING TO NUMBER OF HEATER ELEMENT ROWS INSTALLED. NO MARK INDICATES NO HEAT KIT INSTALLED.

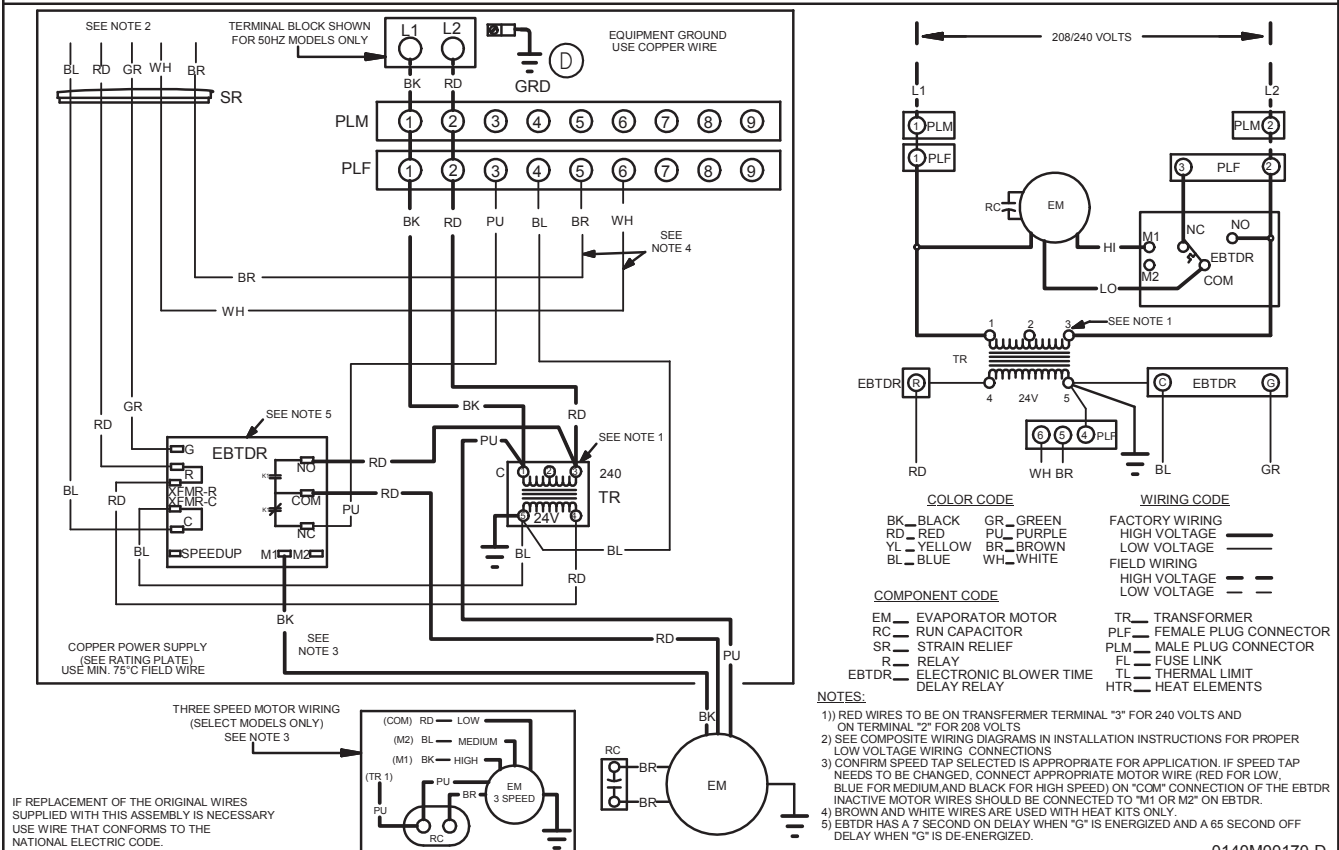

Wiring is subject to change. Always refer to the wiring diagram or the unit for the most up-to-date wiring.



High Voltage: Disconnect all power before servicing or installing this unit. Multiple power sources may be present. Failure to do so may cause property damage, personal injury, or death.

ACCESSORIES

EXPANSION VALVE KITS FOR AIR CONDITIONING AND HEAT PUMP APPLICATIONS

KIT NUMBER	DESCRIPTION	APPLICATION	REFRIGERANT	TONNAGE: OUTDOOR UNIT
XVB18-36C	20% Bleed Valve	AC Only	R-22	1½ - 3 Ton
XVB42-60C	20% Bleed Valve	AC Only	R-22	3½ - 5 Ton
XV18-36C	Non-bleed Valve	AC Only	R-22	1½ - 3 Ton
XV42-60C	Non-bleed Valve	AC Only	R-22	3½ - 5 Ton
TX2N2	Non-bleed Valve	AC or HP	R-22	1½ - 2 Ton
TX3N2	Non-bleed Valve	AC or HP	R-22	2½ - 3 Ton
TX5N2	Non-bleed Valve	AC or HP	R-22	3½ - 5 Ton
TX2N4	Non-bleed Valve	AC or HP	R-410A	1½ - 2 Ton
TX3N4	Non-bleed Valve	AC or HP	R-410A	2½ - 3 Ton
TX5N4	Non-bleed Valve	AC or HP	R-410A	3½ - 5 Ton

DRAIN PAN INSULATION KITS

DOWNFLOW APPLICATIONS

CHASSIS SIZE	INSULATION KIT
Small (15½")	DPI18-30/20
Medium (19½")	DPI36-42/20
Large (22")	DPI48-60/20

HORIZONTAL APPLICATIONS

CHASSIS SIZE	INSULATION KIT
Small (15½")	DPIH18-32
Medium (19½")	DPIH36-42
Large (22")	DPIH48-61

Note: Each kit contains enough material to modify 20 coils

FILTERS

SIZE	FILTER #	QTY REQUIRED
1824	FIL 18-32	1
1931	FIL-36-42	1
3030/ 3636	FIL-36-42	1
3642	FIL 48-61	1
3743	FIL 48-61	1
4860/4961	FIL 48-61	1

