



TRANE®

22-1783-11

Product Data

4TCX3018 through 4TCX3060
Single Packaged Convertible Cooling
13 SEER
1½ - 5 Ton
R-410A

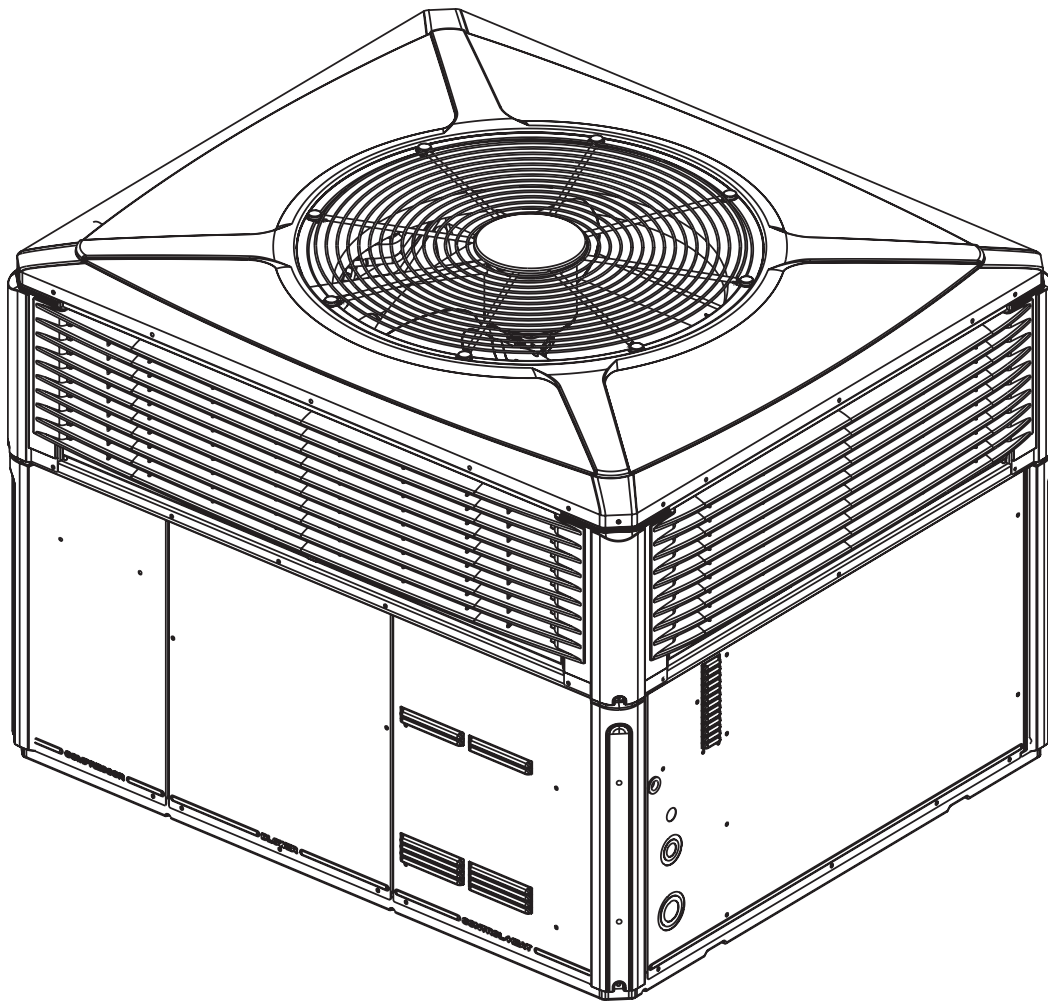

It's Hard to Stop a Trane.

Single Packaged Cooling System

Trane offers a complete family of cooling systems, designed to give you the unbeatable combination of energy efficiency and lower operating costs.

Introducing the new TRANE Single Packaged Cooling System.

Single Packaged Cooling Systems are easy and versatile to install. Because cooling and air handling functions are all contained in a single cabinet, a Trane packaged air conditioner is easy to install and service. It can be flush mounted beside your home at ground level or placed on the roof for horizontal or downflow installation. When connected to an optional Trane thermostat control and air distribution ducts, you have a highly efficient, total home comfort system.

Single Packaged Cooling Systems provide better performance. All major components on these products, including the compressor, have been designed and manufactured for maximum service. Every Climatuff® compressor is designed and manufactured to exacting specifications. Each design is life tested in extreme environments to ensure reliable and long lasting operation in normal applications. Each compressor has internal motor protection for added reliability.

Contents

Optional Equipment Listing	4
<hr/>	
General Data	5
<hr/>	
Heater Data	8
<hr/>	
SPEK Data	9
<hr/>	
Indoor Blower Performance	12
<hr/>	
Typical Wiring	16
<hr/>	
Optional Equipment	19
<hr/>	
Dimensional Data	24
<hr/>	
Mechanical Specifications	30
<hr/>	

Optional Equipment Listing

OPTIONAL EQUIPMENT FOR PACKAGED UNITS (check mark [✓] indicates accessories included)

Hinged Filter Access Door (4TCX3018-36A) ③	BAYACCDOR1A[]
Hinged Filter Access Door (4TCX3042-60A) ③	BAYACCDOR2A[]
Roof Curb Full Perimeter (4TCX3018-36A) ③	BAYCURB050A[]
Roof Curb Full Perimeter (4TCX3042-60A) ③	BAYCURB051A[]
Roof Curb Utility Extension Kit (BAYCURB050A)	BAYUTIL101A[]
Roof Curb Utility Extension Kit (BAYCURB051A)	BAYUTIL102A[]
0-25% Manual Fresh Air Damper (4TCX3018-36A) ①	BAYOSAH001A[]
0-25% Manual Fresh Air Damper (4TCX3042-60A) ①	BAYOSAH002A[]
Motorized Fresh Air Damper (4TCX3018-36A) ①	BAYDMPR101A[]
Motorized Fresh Air Damper (4TCX3042-60A) ①	BAYDMPR102A[]
16" Round Duct Adapter (2 per box) (4TCX3018-36A) ⑥	BAYSQRD001A[]
18" Round Duct Adapter (2 per box) (4TCX3018-60A) ⑥	BAYSQRD002A[]
0-100% Mod Economizer w/Baro. Relief (4TCX3018-36A) ①②④	BAYECON101B[]
0-100% Mod. Economizer w/Baro. Relief (4TCX042-60A) ①②④	BAYECON102B[]
0-100% Horizontal Economizer (4TCX3018-36A) ①②	BAYECON200A[]
0-100% Horizontal Economizer (4TCX3042-60A) ①②	BAYECON201A[]
Enthalpy Control for Economizer (solid state)	BAYENTH001A[]
Remote Potentiometer (All-BAYECON***A)	BAYSTAT023[]
1"-2" Filter Frame (4TCX3018-36A) (20 x 25 filter not included) ①	BAYFLTR101B[]
1"-2" Filter Frame (4TCX3042-60A) (20 x 20 & 20X18 filter not included) ①	BAYFLTR201B[]
Evaporator Defrost Control (Low Ambient Cooling) Kit ⑤	BAYLOAM011A[]
Head Pressure Control (Low Ambient Cool) (208/240v) Kit ⑤	BAYLOAM105A[]
Quick Start Kit (4TCX3-A1)	BAYQSKT301A[]
Crankcase Heater Recip (4TCX3018A1)(230v) ⑤	BAYCCHT101A[]
Crankcase Heater Scroll(4TCX3030, 36,48,60A1/3)(230v) ⑤	BAYCCHT102A[]
Crankcase Heater (4TCX3036,48,60A4)(460v) ⑤	BAYCCHT404B[]
Adapter Curb 4TCX3018-036A to BAYCURB030,38	BAYADAP050A[]
Adapter Curb 4TCX3018-036A to BAYCURB033	BAYADAP051A[]
Adapter Curb 4TCX3042-060A to BAYCURB030,38	BAYADAP052A[]
Adapter Curb 4TCX3042-060A to BAYCURB033	BAYADAP053A[]
Adapter Curb 4TCX3042-060A to BAYCURB034	BAYADAP054A[]
12" Duct Shroud Covers Horizontal 4TCX3018-060A ⑦	BAYCOVR112A[]
18" Duct Shroud Covers Horizontal 4TCX3018-060A ⑦	BAYCOVR118A[]
Extreme Condition Mounting Kit - All BAYCURB & BAYADAP	BAYEXMK001A[]
Extreme Condition Mounting Kit - All BAYUTIL	BAYEXMK002B[]
Extreme Condition Mounting Kit - All Slab Mounts	BAYEXMK003A[]
Lifting Lug Kit	BAYLIFT002B[]
SUPPLEMENTARY HEATERS (1 PHASE)			
3.76/5.0 KW Heater (208/240V 1PH) (4TCX3018-060A1)	BAYHTRV105E[]
6.0/8.0 KW Heater (208/240V 1PH) (4TCX3018-060A1)	BAYHTRV108E[]
7.50/10.0 KW Heater (208/240V 1PH) (4TCX3024-060A1)	BAYHTRV110E[]
11.27/15.00 KW Heater (208/240V 1PH) (4TCX3030-060A1)	BAYHTRV115E[]
15.0/20.0 KW Heater (208/240V 1PH) (4TCX3048-060A1)	BAYHTRV120E[]
SUPPLEMENTARY HEATERS (3 PHASE)			
3.76/5.0 KW Heater (208/240V 3PH) (4TCX3036-060A3)	BAYHTRV305E[]
6.0/8.0 KW Heater (208/240V 3PH) (4TCX3036-060A3)	BAYHTRV308E[]
7.50/10.0 KW Heater (208/240V 3PH) (4TCX3036-060A3)	BAYHTRV310E[]
11.27/15.0 KW Heater (208/240V 3PH) (4TCX3036-060A3)	BAYHTRV315E[]
15.0/20.0 KW Heater (208/240V 3PH) (4TCX3048A3)	BAYHTRV320E[]
5.0 KW Heater (480V 3PH) (4TCX3036-060A4)	BAYHTRV405E[]
8.0 KW Heater (480V 3PH) (4TCX3036-060A4)	BAYHTRV408E[]
10.0 KW Heater (480V 3PH) (4TCX3036-060A4)	BAYHTRV410E[]
15.0 KW Heater (480V 3PH) (4TCX3036-060A4)	BAYHTRV415E[]
20.0 KW Heater (480V 3PH) (4TCX3048-060A4)	BAYHTRV420E[]
Single Power Entry Kit ⑧	BAYSPEK060F[]
Single Power Entry Kit ⑧	BAYSPEK061E[]
Single Power Entry Kit ⑧	BAYSPEK062F[]
Single Power Entry Kit ⑧	BAYSPEK063F[]
Single Power Entry Kit ⑧	BAYSPEK064E[]

- NOTES: ① Must use internal filter frame when economizer or fresh air kit is used.
 ② Dry bulb control standard with economizer.
 ③ Ships knocked down.
 ④ Downflow only.
 ⑤ Low Ambient cooling requires crankcase heater (BAYCCHT----).
 ⑥ It is the responsibility of the installing dealer to properly size the ductwork for each specific application.
 ⑦ BAYCOVR112,118A will not cover BAYSQRD002A applications.
 ⑧ See table on page 8 for matching kit with units and heaters.

General Data

MODEL	4TCX3018A1000B	4TCX3024A1000B	4TCX3030B1000A	4TCX3036A1000B	4TCX3036A3000B
RATED Volts/Ph/Hz	208-230/1/60	208-230/1/60	208-230/1/60	208-230/1/60	208-230/3/60
Performance Cooling BTUH^①	18000	24000	29200	36000	36000
Indoor Airflow (CFM)	675	725	1010	1200	1200
Power Input (KW)	1.68	2.13	2.65	3.29	3.29
EER/SEER (BTU/Watt-Hr.) ^⑥	11.0 / 13.0	11.2 / 13.0	11.0 / 13.0	11.0 / 13.2	11.0 / 13.2
Sound Power Rating [dB(A)] ^②	69	70	74	72	72
POWER CONN.—V/Ph/Hz	208-230/1/60	208-230/1/60	208-230/1/60	208-230/1/60	208-230/3/60
Min. Brch. Cir. Ampacity ^③	10.1	13.6	17.1	24.9	16.8
Fuse Size — Max. (amps)	15	20	25	40	25
Fuse Size — Recmd. (amps)	15	20	25	40	25
COMPRESSOR	RECIPROCATING	RECIPROCATING	SCROLL	SCROLL	SCROLL
Volts/Ph/Hz	208-230/1/60	200-230/1/60	208-230/1/60	208-230/1/60	208-230/3/60
R.L. Amps — L.R. Amps	6.4 / 38.6	8.3 / 57.8	11.4 / 68.2	16.7 / 79	10.4 / 73
OUTDOOR COIL — TYPE	SPINE-FIN	SPINE-FIN	SPINE-FIN	SPINE-FIN	SPINE-FIN
Rows/F.P.I.	2 / 24	2 / 24	2 / 24	2 / 24	2 / 24
Face Area (sq.ft.)	13.32	13.32	13.32	13.32	13.32
Tube Size (in.)	3/8	3/8	3/8	3/8	3/8
INDOOR COIL — TYPE	PLATE FIN	PLATE FIN	PLATE FIN	PLATE FIN	PLATE FIN
Rows/F.P.I.	3 / 15	3 / 15	3 / 15	4 / 15	4 / 15
Face Area (sq.ft.)	3.54	3.54	3.54	3.54	3.54
Tube Size (in.)	3/8	3/8	3/8	3/8	3/8
Refrigerant Control	EXPANSION VALVE	EXPANSION VALVE	EXPANSION VALVE	EXPANSION VALVE	EXPANSION VALVE
Drain Conn. Size (in.)	3/4 FEMALE NPT	3/4 FEMALE NPT	3/4 FEMALE NPT	3/4 FEMALE NPT	3/4 FEMALE NPT
OUTDOOR FAN — TYPE	PROPELLER	PROPELLER	PROPELLER	PROPELLER	PROPELLER
Dia. (in.)	23.4	23.4	23.4	23.4	23.4
Drive/No. Speeds	DIRECT / 1	DIRECT / 1	DIRECT / 1	DIRECT / 1	DIRECT / 1
CFM @ 0.0 in. w.g. ^④	2580	2580	3230	3280	3280
Motor — HP/R.P.M.	1/12 / 810	1/12 / 810	1/6 / 825	1/5 / 830	1/5 / 830
Volts/Ph/Hz	230/1/60	230/1/60	208-230/1/60	230/1/60	230/1/60
F.L. Amps/L.R. Amps	0.5 / 0.95	0.9 / 0.95	1.0 / 1.7	1.1 / 1.9	1.1 / 1.9
INDOOR FAN — TYPE	CENTRIFUGAL	CENTRIFUGAL	CENTRIFUGAL	CENTRIFUGAL	CENTRIFUGAL
Dia x Width (in.)	11 X 10	11 X 10	10 X 10	10 X 10	10 X 10
Drive/No. Speeds	DIRECT / 2	DIRECT / 2	DIRECT / 3	DIRECT / 3	DIRECT / 3
CFM @ 0.0 in. w.g. ^⑤	SEE FAN PERF TABLE	SEE FAN PERF TABLE	SEE FAN PERF TABLE	SEE FAN PERF TABLE	SEE FAN PERF TABLE
Motor — HP/R.P.M.	1/8 / 825	1/4 / 825	1/2 / 1080	1/2 / 1075	1/2 / 1075
Volts/Ph/Hz	200-230/1/60	200-230/1/60	200-230/1/60	200-230/1/60	200-230/1/60
F.L. Amps/L.R. Amps	1.0 / 1.5	1.4 / 2.8	2.0 / 4.4	2.7 / 5.8	2.7 / 5.8
FILTER / FURNISHED	NO	NO	NO	NO	NO
Type Recommended	THROWAWAY	THROWAWAY	THROWAWAY	THROWAWAY	THROWAWAY
Recmd. Face Area (sq. ft.) ^⑦	4.0	4.0	4.0	4.0	4.0
REFRIGERANT	R-410	R-410	R-410	R-410	R-410
Charge (lbs.)	6.10	6.00	6.13	8.00	8.00
DIMENSIONS	H X W X L	H X W X L	H X W X L	H X W X L	H X W X L
Crated (in.)	45.86 / 44.5 / 52.03	45.86 / 44.5 / 52.03	45.86 / 44.5 / 52.03	45.86 / 44.5 / 52.03	45.86 / 44.5 / 52.03
WEIGHT					
Shipping (lbs.) / Net (lbs.)	444 / 348	444 / 348	445 / 349	450 / 354	450 / 354

① Rated in accordance with AHRI Standard 210/240.

② Sound Power values are not adjusted for AHRI 270-95 tonal corrections.

③ Calculated in accordance with currently prevailing Nat'l Electrical Code.

④ Standard Air -- Dry Coil -- Outdoor.

⑤ Standard Air -- Dry Coil -- Indoor.

⑥ Rated in accordance with D.O.E. test procedure.

⑦ Filters must be installed in return air stream. Square footages listed are based on 300 f.p.m. face velocity. If permanent filters are used size per manufacturer's recommendation with a clean resistance of 0.05" W.C.

General Data

MODEL	4TCX3036A4000B	4TCX3042B1000A	4TCX3048A1000B	4TCX3048A3000B	4TCX3048A4000B
RATED Volts/Ph/Hz	460/3/60	208-230/1/60	208-230/1/60	208-230/3/60	460/3/60
Performance Cooling BTUH^①	36000	41500	46500	46500	46500
Indoor Airflow (CFM)	1200	1450	1600	1600	1600
Power Input (KW)	3.29	3.77	4.23	4.23	4.23
EER/SEER (BTU/Watt-Hr.) ^②	11.0 / 13.2	11.0 / 13.0	11.0 / 13.0	11.0 / 13.0	11.0 / 13.0
Sound Power Rating [dB(A)] ^②	72	74	72	72	72
POWER CONN.—V/Ph/Hz	460/3/60	208-230/1/60	208-230/1/60	208-230/3/60	460/3/60
Min. Brch. Cir. Ampacity ^③	9.6	26.5	32.7	22.5	10.7
Fuse Size — Max. (amps)	15	40	50	35	15
Fuse Size — Recmd. (amps)	15	40	50	35	15
COMPRESSOR	SCROLL	SCROLL	SCROLL	SCROLL	SCROLL
Volts/Ph/Hz	460/3/60	208-230/1/60	208-230/1/60	208-230/3/60	460/3/60
R.L. Amps — L.R. Amps	5.8 / 38	17.9 / 112	21.8 / 117	13.7 / 83.1	6.2 / 41
OUTDOOR COIL — TYPE	SPINE-FIN	SPINE-FIN	SPINE-FIN	SPINE-FIN	SPINE-FIN
Rows/F.P.I.	2 / 24	2 / 24	2 / 24	2 / 24	2 / 24
Face Area (sq.ft.)	13.32	18.01	18.01	18.01	18.01
Tube Size (in.)	3/8	3/8	3/8	3/8	3/8
INDOOR COIL — TYPE	PLATE FIN	PLATE FIN	PLATE FIN	PLATE FIN	PLATE FIN
Rows/F.P.I.	4 / 15	3 / 15	3 / 15	3 / 15	3 / 15
Face Area (sq.ft.)	3.54	5	5	5	5
Tube Size (in.)	3/8	3/8	3/8	3/8	3/8
Refrigerant Control	EXPANSION VALVE	EXPANSION VALVE	EXPANSION VALVE	EXPANSION VALVE	EXPANSION VALVE
Drain Conn. Size (in.)	3/4 FEMALE NPT	3/4 FEMALE NPT	3/4 FEMALE NPT	3/4 FEMALE NPT	3/4 FEMALE NPT
OUTDOOR FAN — TYPE	PROPELLER	PROPELLER	PROPELLER	PROPELLER	PROPELLER
Dia. (in.)	23.4	28	28	28	28
Drive/No. Speeds	DIRECT / 1	DIRECT / 1	DIRECT / 1	DIRECT / 1	DIRECT / 1
CFM @ 0.0 in. w.g. ^④	3280	4430	4430	4430	4430
Motor — HP/R.P.M.	1/5 / 830	1/4 / 825	1/4 / 825	1/4 / 825	1/4 / 825
Volts/Ph/Hz	460/1/60	208-230/1/60	230/1/60	230/1/60	460/1/60
F.L. Amps/L.R. Amps	0.6 / 1.3	1.5 / 3.07	1.4 / 3.5	1.4 / 3.5	0.7 / 1.6
INDOOR FAN — TYPE	CENTRIFUGAL	CENTRIFUGAL	CENTRIFUGAL	CENTRIFUGAL	CENTRIFUGAL
Dia x Width (in.)	10 X 10	10 X 10	10 X 10	10 X 10	10 X 10
Drive/No. Speeds	DIRECT / 2	DIRECT / 3	DIRECT / 3	DIRECT / 3	DIRECT / 2
CFM @ 0.0 in. w.g. ^⑤	SEE FAN PERF TABLE	SEE FAN PERF TABLE	SEE FAN PERF TABLE	SEE FAN PERF TABLE	SEE FAN PERF TABLE
Motor — HP/R.P.M.	1/2 / 1075	1/2 / 1075	3/4 / 1080	3/4 / 1080	3/4 / 1080
Volts/Ph/Hz	460/1/60	200-230/1/60	200-230/1/60	200-230/1/60	460/1/60
F.L. Amps/L.R. Amps	1.7 / 3.12	2.5 / 3.2	4.0 / 8.4	4.0 / 8.4	2.2 / 4.36
FILTER / FURNISHED	NO	NO	NO	NO	NO
Type Recommended	THROWAWAY	THROWAWAY	THROWAWAY	THROWAWAY	THROWAWAY
Recmd. Face Area (sq. ft.) ^⑦	4.0	5.3	5.3	5.3	5.3
REFRIGERANT	R-410	R-410	R-410	R-410	R-410
Charge (lbs.)	8.00	7.51	8.50	8.50	8.5
DIMENSIONS	H X W X L	H X W X L	H X W X L	H X W X L	H X W X L
Crated (in.)	45.86 / 44.5 / 52.03	47.86 / 47.4 / 61.75	47.86 / 47.4 / 61.75	47.86 / 47.4 / 61.75	47.86 / 47.4 / 61.75
WEIGHT					
Shipping (lbs.) / Net (lbs.)	450 / 354	523 / 395	607 / 479	607 / 479	607 / 479

① Rated in accordance with AHRI Standard 210/240.

② Sound Power values are not adjusted for AHRI 270-95 tonal corrections.

③ Calculated in accordance with currently prevailing Nat'l Electrical Code.

④ Standard Air -- Dry Coil -- Outdoor.

⑤ Standard Air -- Dry Coil -- Indoor.

⑥ Rated in accordance with D.O.E. test procedure.

⑦ Filters must be installed in return air stream. Square footages listed are based on 300 f.p.m. face velocity. If permanent filters are used size per manufacturer's recommendation with a clean resistance of 0.05" W.C.

General Data

MODEL	4TCX3060A1000B	4TCX3060A3000B	4TCX3060A4000B
RATED Volts/Ph/Hz	208-230/1/60	208-230/3/60	460/3/60
Performance Cooling BTUH^①	60000	60000	60000
Indoor Airflow (CFM)	1800	1800	1800
Power Input (KW)	5.48	5.48	5.48
EER/SEER (BTU/Watt-Hr.) ^⑥	11.0 / 13	11.0 / 13.2	11.0 / 13.2
Sound Power Rating [dB(A)] ^②	72	72	72
POWER CONN.—V/Ph/Hz	208-230/1/60	208-230/3/60	460/3/60
Min. Brch. Cir. Ampacity ^③	41.9	28.5	18.1
Fuse Size — Max. (amps)	60	40	25
Fuse Size — Recmd. (amps)	60	40	25
COMPRESSOR	SCROLL	SCROLL	
Volts/Ph/Hz	208-230/1/60	208-230/3/60	460/3/60
R.L. Amps — L.R. Amps	26.3 / 134	15.6 / 110	7.8 / 52
OUTDOOR COIL — TYPE	SPINE-FIN	SPINE-FIN	SPINE-FIN
Rows/F.P.I.	2 / 24	2 / 24	2 / 24
Face Area (sq.ft.)	20.54	20.54	20.54
Tube Size (in.)	3/8	3/8	3/8
INDOOR COIL — TYPE	PLATE FIN	PLATE FIN	PLATE FIN
Rows/F.P.I.	4 / 15	4 / 15	4 / 15
Face Area (sq.ft.)	5	5	5
Tube Size (in.)	3/8	3/8	3/8
Refrigerant Control	EXPANSION VALVE	EXPANSION VALVE	EXPANSION VALVE
Drain Conn. Size (in.)	3/4 FEMALE NPT	3/4 FEMALE NPT	3/4 FEMALE NPT
OUTDOOR FAN — TYPE	PROPELLER	PROPELLER	PROPELLER
Dia. (in.)	28	28	28
Drive/No. Speeds	DIRECT / 1	DIRECT / 1	DIRECT / 1
CFM @ 0.0 in. w.g. ^④	4430	4430	4430
Motor — HP/R.P.M.	1/4 / 825	1/4 / 825	1/4 / 825
Volts/Ph/Hz	230/1/60	230/1/60	460/1/60
F.L. Amps/L.R. Amps	1.4 / 3.5	1.4 / 3.5	0.7 / 1.6
INDOOR FAN — TYPE	CENTRIFUGAL	CENTRIFUGAL	CENTRIFUGAL
Dia x Width (in.)	11 X 10	11 X 10	11 X 10
Drive/No. Speeds	DIRECT / 3	DIRECT / 3	DIRECT / 3
CFM @ 0.0 in. w.g. ^⑤	SEE FAN PERF TABLE	SEE FAN PERF TABLE	SEE FAN PERF TABLE
Motor — HP/R.P.M.	1 / 1075	1 / 1075	1 / 1075
Volts/Ph/Hz	208-230/1/60	208-230/1/60	208-230/1/60
F.L. Amps/L.R. Amps	7.6 / 7.4	7.6 / 7.4	7.6 / 7.4
FILTER / FURNISHED	NO	NO	NO
Type Recommended	THROWAWAY	THROWAWAY	THROWAWAY
Recmd. Face Area (sq. ft.) ^⑦	5.3	5.3	5.3
REFRIGERANT	R-410A	R-410A	R-410A
Charge (lbs.)	10.30	10.30	10.30
DIMENSIONS	H X W X L	H X W X L	H X W X L
Crated (in.)	49.86 / 47.4 / 61.75	49.86 / 47.4 / 61.75	49.86 / 47.4 / 61.75
WEIGHT			
Shipping (lbs.) / Net (lbs.)	610 / 482	610 / 482	610 / 482

① Rated in accordance with AHRI Standard 210/240.

② Sound Power values are not adjusted for AHRI 270-95 tonal corrections.

③ Calculated in accordance with currently prevailing Nat'l Electrical Code.

④ Standard Air -- Dry Coil -- Outdoor.

⑤ Standard Air -- Dry Coil -- Indoor.

⑥ Rated in accordance with D.O.E. test procedure.

⑦ Filters must be installed in return air stream. Square footages listed are based on 300 f.p.m. face velocity. If permanent filters are used size per manufacturer's recommendation with a clean resistance of 0.05" W.C.

Heater Data

UNIT MODEL	ELECTRIC HEATER MODEL	RATED VOLTAGE	PHASE	AMPS	HEATER CAPACITY		NO. OF STAGES	KW/STAGE		MCA	MAX FUSE OR HACR CKT BKR SIZE (4)	CANADA ONLY MAX. CKT BKR SIZE (5)
					KW	BTUH		1	2			
^W/TC*3018-060#1 ^W/TCY4024-060#1 ^WCZ6036-060#1	BAYHTRV105E	208/240	1	18/21	3.76/5.0	12800/17100	1	3.76/5.0		23/26	25/30	25/30
^W/TC*3018-060#1 ^W/TCY4024-060#1 ^WCZ6036-060#1	BAYHTRV108E	208/240	1	29/33	6.0/8.0	20500/27300	1	6.0/8.0		36/41	40/45	40/45
^W/TC*3024-060#1 ^W/TCY4024-060#1 ^WCZ6036-060#1	BAYHTRV110E	208/240	1	36/42	7.5/10.0	25600/34100	1	7.5/10.0		45/52	45/60	45/60
^W/TC*3030-060#1 ^W/TCY4030-060#1 ^WCZ6036-060#1	BAYHTRV115E#	208/240	1	54/63	11.27/15.0	38500/51200	2	7.5/10.0	3.76/5.0	68/78	70/80	70/80
^W/TC*3042-060#1 ^W/TCY4042-060#1 ^WCZ6048-060#1	BAYHTRV120E#	208/240	1	72/83	15.0/20.0	51200/68300	2	7.5/10.0	7.5/10.0	90/104	90/110	90/110
4WC*3042#1 ^W/TC*3060#1 ^W/TCY4042-060#1 ^WCZ6048-060#1	BAYHTRV125E#	208/240	1	90/104	18.78/25.0	64100/85300	2	11.26/15.0	7.5/10.0	113/130	125/150	125/150
^W/TC*3036-060#3 ^W/TCY4036-060#3 ^WCZ6036-060#3	BAYHTRV305E	208/240	3	10/12	3.76/5.0	12800/17100	1	3.76/5.0		13/15	15/15	15/15
^W/TC*3036-060#3 ^W/TCY4036-060#3 ^WCZ6036-060#3	BAYHTRV308E	208/240	3	17/19	6.0/8.0	20500/27300	1	6.0/8.0		21/24	25/25	25/25
^W/TC*3036-060#3 ^W/TCY4036-060#3 ^WCZ6036-060#3	BAYHTRV310E	208/240	3	21/24	7.5/10.0	25600/34100	1	7.5/10.0		26/30	30/30	30/30
^W/TC*3036-060#3 ^W/TCY4036-060#3 ^WCZ6036-060#3	BAYHTRV315E	208/240	3	31/36	11.27/15.0	38500/51200	2	7.5/10.0	3.76/5.0	39/45	40/45	40/45
^W/TC*3048-060#3 ^W/TCY4048-060#3 ^WCZ6048-060#3	BAYHTRV320E	208/240	3	42/48	15.0/20.0	51200/68300	2	7.5/10.0	7.5/10.0	52/60	60/60	60/60
^W/TC*3060#3 ^W/TCY4048-060#3 ^WCZ6048-060#3	BAYHTRV325E#	208/240	3	52/60	18.78/25.0	64100/85300	2	11.26/15.0	7.5/10.0	65/75	70/80	70/80
^W/TC*3036-060#4 ^WCZ6036-060#4	BAYHTRV405E	480	3	6	5.0	17100	1	5.0		8	15	15
^W/TC*3036-060#4 ^WCZ6036-060#4	BAYHTRV408E	480	3	10	8.0	27300	1	8.0		13	15	15
^W/TC*3036-060#4 ^WCZ6036-060#4	BAYHTRV410E	480	3	12	10.0	34100	1	10.0		15	15	15
^W/TC*3036-060#4 ^WCZ6036-060#4	BAYHTRV415E	480	3	18	15.0	51200	2	10.0	5.0	23	25	25
^W/TC*3048-060#4 ^WCZ6048-060#4	BAYHTRV420E	480	3	24	20.0	68300	2	10.0	10.0	30	30	30
^W/TC*3060#4 ^WCZ6048-060#4	BAYHTRV425E	480	3	30	25.0	85300	2	15.0	10.0	38	40	40

NOTES:

1. Any power supply and circuits must be wired and protected in accordance with local electrical codes.
 - (2) The MCA values listed are for electric heater only.
 3. Field wire must be rated at least 75°C
 - (4) The HACR circuit breaker is for U.S.A. installations only.
 - (5) For Canada installation reference only.
- * Heater uses fuses.

Single Power Entry Kit Data

SINGLE POWER ENTRY KIT	HEATER MODEL	CHECK	UNIT MODEL	MIN CKT. AMP.	MAX OVER CURRENT PROTECT DEVICE	
BAYSPEK060F	BAYHTRV105E		4TC•3018AI	27	30	
			4TC•3024AI	28	30	
			4TC•3030AI	29	35	
			4TC•3036AI	30	35	
			4TC•3042AI	29	45	
			4TC•3048AI	31	50	
			4TCY4024AI	31	35	
			4TCY4030AI	31	35	
			4TCY4036AI	31	40	
			4TCY4036BI	31	40	
			4TCY4042AI	35	50	
			4TCY4042BI	35	50	
			4TCY4048AI	35	50	
			4TCY4048BI	35	50	
			4TCY4060AI	42	60	
			2WC•3024AI	39	40	
			2WC•3030AI	43	45	
			2WC•3036AI	50	60	
			2WC•3042AI	51	60	
			2WC•3048AI	55	60	
			4WC•3018AI	37	40	
			4WC•3024AI	42	45	
			4WC•3024BI	40	40	
			4WC•3030AI	45	50	
			4WC•3036AI	52	60	
			4WCY4024AI	42	45	
			4WCY4030AI	45	50	
			4WCY4036AI	51	60	
		4WCY4036BI	51	60		
		4WCZ6036AI	52	60		
		BAYHTRV108E		4TC•3018AI	43	45
				4TC•3024AI	43	45
				4TC•3030AI	44	45
				4TC•3036AI	45	45
				4TC•3042AI	45	45
				4TC•3048AI	47	50
				4TCY4024AI	47	50
				4TCY4030AI	47	50
				4TCY4036AI	47	50
				4TCY4036BI	47	50
				4TCY4042AI	50	60
				4TCY4042BI	50	60
				4TCY4048AI	50	60
				4TCY4048BI	50	50
				4TCY4060AI	50	60
				2WC•3024AI	54	60
				2WC•3030AI	59	60
			4WC•3018AI	52	60	
		4WC•3024AI	58	60		
		4WC•3024BI	55	60		
		4WCY4024AI	58	60		
	BAYHTRV110E		4TC•3024AI	54	60	
			4TC•3030AI	55	60	
			4TC•3036AI	56	60	
			4TC•3042AI	55	60	
			4TC•3048AI	57	60	
			4TCY4024AI	58	60	
			4TCY4030AI	58	60	
		4TCY4036AI	58	60		
			4TCY4036BI	58	60	

INSTALLER OF THE SINGLE POWER ENTRY KIT MUST CHECK THE APPROPRIATE BOX ABOVE TO RECORD THE KIT, HEATER AND UNIT MODEL NUMBERS INSTALLED. POWER SUPPLY VOLTAGE TO UNIT AND HEATER MUST BE IDENTICAL. CHECK THE UNIT AND HEATER NAMEPLATES TO DETERMINE THE CORRECT POWER SUPPLY VOLTAGE. CHECK HEATER NAMEPLATE TO DETERMINE HEATER KW AND CURRENT RATING. MINIMUM INSTALLATION CLEARANCE TO COMBUSTIBLE MATERIAL WHEN ELECTRIC HEATERS ARE INSTALLED: UNIT CABINET-0", PLENUM-0" AND OUTLET DUCT- 0".
 • INDICATES AN ALPHA CHARACTER IN THE FOURTH DIGIT OF THE UNIT MODEL.

PLACE ABOVE LABEL OVER "ELECTRIC HEATER INSTALLED" NAMEPLATE ON UNIT

D932299P04

Single Power Entry Kit Data

SINGLE POWER ENTRY KIT	HEATER MODEL	UNIT MODEL	MIN CKT. AMP.	MAX OVER CURRENT PROTECT DEVICE	SINGLE POWER ENTRY KIT	HEATER MODEL	UNIT MODEL	MIN CKT. AMP.	MAX OVER CURRENT PROTECT DEVICE			
BAYSPEK061E	BAYHTRV305E	4TC*3036+3	18	30	BAYSPEK061E	BAYHTRV405E	4TC*3036+4	10	15			
		4TC*3048+3	24	35			4TC*3048+4	12	15			
		4TC*3060+3	32	45			4TC*3060+4	20	25			
		4TCY4036+3	20	30			4WC*3036+4	16	20			
		4TCY4048+3	26	40			4WC*3048+4	19	25			
		4TCY4060+3	31	45			4WC*3060+4	27	30			
		4WC*3036+3	33	40			4WCZ6036+4	18	20			
		4WC*3048+3	39	50			4WCZ6048+4	23	25			
		4WC*3060+3	47	60			4WCZ6060+4	27	30			
		4WCY4036+3	35	40			4TC*3036+4	14	15			
		4WCY4048+3	41	50			4TC*3048+4	15	15			
		4WCY4060+3	46	60			4TC*3060+4	22	25			
		4WCZ6036+3	34	40			4WC*3036+4	21	25			
		4WCZ6048+3	40	50			4WC*3048+4	24	25			
		4WCZ6060+3	45	60			4WC*3060+4	32	35			
		BAYHTRV308E	4TC*3036+3	27			30	4WCZ6036+4	22	25		
			4TC*3048+3	29			35	4WCZ6048+4	27	30		
			4TC*3060+3	34			45	4WCZ6060+4	31	35		
	4TCY4036+3		29	30		4TC*3036+4	17	20				
	4TCY4048+3		33	40		4TC*3048+4	18	20				
	4TCY4060+3		33	45		4TC*3060+4	25	25				
	4WC*3036+3		42	45		4WC*3036+4	24	25				
	4WC*3048+3		48	50		4WC*3048+4	27	30				
	4WC*3060+3		56	60		4WC*3060+4	35	40				
	4WCY4036+3		44	50		4WCZ6036+4	25	25				
	4WCY4048+3		50	60		4WCZ6048+4	30	30				
	4WCY4060+3		55	60		4WCZ6060+4	34	40				
	4WCZ6036+3		43	45		4TC*3036+4	25	25				
	4WCZ6048+3		49	50		4TC*3048+4	25	25				
	4WCZ6060+3		54	60		4TC*3060+4	32	35				
	BAYHTRV310E		4TC*3036+3	33		35	4WC*3036+4	31	35			
			4TC*3048+3	35		35	4WC*3048+4	34	35			
			4TC*3060+3	40		45	4WC*3060+4	42	45			
		4TCY4036+3	35	35		4WCZ6036+4	33	35				
		4TCY4048+3	39	40		4WCZ6048+4	38	40				
		4TCY4060+3	39	45		4WCZ6060+4	42	45				
		4WC*3036+3	48	50		4TC*3048+4	33	35				
		4WC*3048+3	54	60		4TC*3060+4	40	40				
		4WCY4036+3	50	50		4WC*3048+4	42	45				
		4WCY4048+3	56	60		4WC*3060+4	50	50				
		4WCZ6036+3	49	50		4WCZ6048+4	45	45				
		4WCZ6048+3	55	60		4WCZ6060+4	49	50				
		BAYHTRV315E	4TC*3036+3	48		50	INSTALLER OF THE SINGLE POWER ENTRY KIT MUST CHECK THE APPROPRIATE BOX ABOVE TO RECORD THE KIT, HEATER AND UNIT MODEL NUMBERS INSTALLED. POWER SUPPLY VOLTAGE TO UNIT AND HEATER MUST BE IDENTICAL. CHECK THE UNIT AND HEATER NAMEPLATES TO DETERMINE THE CORRECT POWER SUPPLY VOLTAGE. CHECK HEATER NAMEPLATE TO DETERMINE HEATER KW AND CURRENT RATING. MINIMUM INSTALLATION CLEARANCE TO COMBUSTIBLE MATERIAL WHEN ELECTRIC HEATERS ARE INSTALLED: UNIT CABINET-0", PLENUM-0" AND OUTLET DUCT-0" EXCEPT FOR BAYHTRV415E AND BAYHTRV425E WHEN INSTALLED IN 4WCZ6060A4 UNIT ONLY. MINIMUM INSTALLATION CLEARANCE TO COMBUSTIBLE MATERIAL WHEN BAYHTRV415E AND BAYHTRV425E ARE INSTALLED IN 4WCZ6060A4 UNIT ONLY: UNIT CABINET - 1", PLENUM -1" AND OUTLET DUCT - 1". * INDICATES AN ALPHA CHARACTER IN THE FOURTH DIGIT OF THE UNIT MODEL.					
			4TC*3048+3	50		50						
			4TC*3060+3	55		60						
			4TCY4036+3	50		50						
			4TCY4048+3	54		60						
			4TCY4060+3	54		60						
	BAYSPEK061E	BAYHTRV408E	4TC*3036+4	14		15	BAYSPEK061E	BAYHTRV410E	4TC*3036+4	17	20	
			4TC*3048+4	15		15			4TC*3048+4	18	20	
4TC*3060+4			22	25	4TC*3060+4	25			25			
4WC*3036+4			21	25	4WC*3036+4	24			25			
4WC*3048+4			24	25	4WC*3048+4	27			30			
4WC*3060+4			32	35	4WC*3060+4	35			40			
4WCZ6036+4			22	25	4WCZ6036+4	25			25			
4WCZ6048+4			27	30	4WCZ6048+4	30			30			
4WCZ6060+4			31	35	4WCZ6060+4	34			40			
BAYHTRV415E			4TC*3036+4	25	25	BAYHTRV420E			4TC*3048+4	33	35	
			4TC*3048+4	25	25				4TC*3060+4	40	40	
			4TC*3060+4	32	35				4WC*3048+4	42	45	
		4WC*3036+4	31	35	4WC*3060+4			50	50			
		4WC*3048+4	34	35	4WCZ6048+4			45	45			
		4WC*3060+4	42	45	4WCZ6060+4			49	50			

Single Power Entry Kit Data

SINGLE POWER ENTRY KIT	HEATER MODEL	CHECK	UNIT MODEL	MIN CKT. AMP.	MAX OVER CURRENT PROTECT DEVICE	
BAYSPEK062F	BAYHTRV105E		4TC*3060A1	44	70	
			2WC*3060A1	67	80	
			4WC*3042A1	58	70	
			4WC*3048A1	57	70	
			4WC*3060A1	70	90	
			4WCY4042A1	58	70	
			4WCY4048A1	60	70	
			4WCY4048B1	62	70	
			4WCY4060A1	68	90	
			4WCY4060B1	66	80	
			4WCZ6048A1	60	70	
			4WCZ6060A1	63	80	
		BAYHTRV108E		4TC*3060A1	51	70
				2WC*3036A1	66	70
				2WC*3042A1	66	70
				2WC*3048A1	70	80
				2WC*3060A1	82	90
				4WC*3030A1	61	70
			4WC*3036A1	67	70	
			4WC*3042A1	73	80	
			4WC*3048A1	73	80	
			4WC*3060A1	85	100	
			4WCY4030A1	61	70	
			4WCY4036A1	66	70	
			4WCY4036B1	66	70	
			4WCY4042A1	73	80	
			4WCY4048A1	76	80	
			4WCY4048B1	77	90	
			4WCY4060A1	84	100	
			4WCY4060B1	82	90	
	BAYHTRV110E		4WCZ6036A1	68	70	
			4WCZ6048A1	76	80	
			4WCZ6060A1	79	90	
			4TC*3060A1	62	70	
			4TCY4042A1	61	70	
			4TCY4042B1	61	70	
			4TCY4048A1	61	70	
			4TCY4048B1	61	70	
			4TCY4060A1	61	70	
			2WC*3024A1	65	70	
			2WC*3030A1	69	70	
			2WC*3036A1	76	80	
			2WC*3042A1	77	80	
			2WC*3048A1	81	90	
			2WC*3060A1	93	100	
			4WC*3024A1	68	70	
			4WC*3024B1	66	70	
			4WC*3030A1	71	80	
		4WC*3036A1	78	80		
		4WC*3042A1	84	90		
		4WC*3048A1	83	90		
		4WC*3060A1	96	110		
		4WCY4024A1	68	70		
		4WCY4030A1	71	80		
	4WCY4036A1	77	80			
	4WCY4036B1	77	80			
	4WCY4042A1	84	90			
	4WCY4048A1	86	90			
	4WCY4048B1	88	90			
	4WCY4060A1	94	110			
	4WCY4060B1	92	100			
	4WCZ6036A1	78	80			
	4WCZ6048A1	86	90			
	4WCZ6060A1	89	100			

BAYSPEK063F	BAYHTRV115E		4TC*3030A1	81	90		
			4TC*3036A1	82	90		
			4TC*3042A1	81	90		
			4TC*3048A1	83	90		
			4TC*3060A1	88	90		
			4TCY4030A1	84	90		
			4TCY4036A1	84	90		
			4TCY4036B1	84	90		
			4TCY4042A1	87	90		
			4TCY4042B1	87	90		
			4TCY4048A1	87	90		
			4TCY4048B1	87	90		
			4TCY4060A1	87	90		
			2WC*3030A1	95	100		
			2WC*3036A1	102	110		
			2WC*3042A1	103	110		
			2WC*3048A1	107	110		
			2WC*3060A1	119	125		
		4WC*3030A1	97	100			
		4WC*3036A1	104	110			
		4WC*3042A1	110	110			
		4WC*3048A1	109	110			
		4WC*3060A1	122	125			
		4WCY4030A1	97	100			
		4WCY4036A1	103	110			
		4WCY4036B1	103	110			
		4WCY4042A1	110	110			
		4WCY4048A1	112	125			
		4WCY4048B1	114	125			
		4WCY4060A1	120	125			
		4WCY4060B1	118	125			
		4WCZ6036A1	104	110			
		4WCZ6048A1	112	125			
		4WCZ6060A1	115	125			
		4TC*3048A1	109	110			
		4TC*3060A1	114	125			
		4TCY4042A1	113	125			
		4TCY4042B1	113	125			
		4TCY4048A1	113	125			
		4TCY4048B1	113	125			
		4TCY4060A1	113	125			
		2WC*3048A1	133	150			
		2WC*3060A1	145	150			
		4WC*3042A1	136	150			
		4WC*3048A1	135	150			
		4WC*3060A1	148	150			
		4WCY4042A1	136	150			
		4WCY4048A1	138	150			
		4WCY4048B1	140	150			
		4WCY4060A1	146	150			
		4WCY4060B1	144	150			
		4WCZ6048A1	138	150			
		4WCZ6060A1	141	150			
	BAYHTRV120E		4WC*3036A3	63	70		
		4WC*3048A3	69	70			
		4WC*3060A3	77	80			
		4WCY4036A3	65	70			
		4WCY4048A3	71	80			
		4WCY4060A3	76	80			
		4WCZ6036A3	64	70			
		4WCZ6048A3	70	70			
		4WCZ6060A3	75	80			
BAYHTRV315E			4TC*3048A3	65	70		
			4TC*3060A3	70	70		
			4TCY4048A3	69	70		
			4TCY4060A3	69	70		
		BAYHTRV320E		4WC*3048A3	84	90	
				4WC*3060A3	92	100	
				4WCY4048A3	86	90	
				4WCY4060A3	91	100	
				4WCZ6048A3	85	90	
			4WCZ6060A3	90	90		
	BAYSPEK065E		BAYHTRV310E		4WC*3060A3	62	70
					4WCY4060A3	61	70
					4WCZ6060A3	60	70

INSTALLER OF THE SINGLE POWER ENTRY KIT MUST CHECK THE APPROPRIATE BOX ABOVE TO RECORD THE KIT, HEATER AND UNIT MODEL NUMBERS INSTALLED. POWER SUPPLY VOLTAGE TO UNIT AND HEATER MUST BE IDENTICAL. CHECK THE UNIT AND HEATER NAMEPLATES TO DETERMINE THE CORRECT POWER SUPPLY VOLTAGE. CHECK HEATER NAMEPLATE TO DETERMINE HEATER KW AND CURRENT RATING. MINIMUM INSTALLATION CLEARANCE TO COMBUSTIBLE MATERIAL WHEN ELECTRIC HEATERS ARE INSTALLED: UNIT CABINET-0", PLENUM-0" AND OUTLET DUCT- 0". * INDICATES AN ALPHA CHARACTER IN THE FOURTH DIGIT OF THE UNIT MODEL.

PLACE ABOVE LABEL OVER "ELECTRIC HEATER INSTALLED" NAMEPLATE ON UNIT

D932299P05

Indoor Blower Performance

Indoor Fan Performance 4TC*3018A

Horizontal Airflow

4TC*3018A1 -HOR		EXTERNAL STATIC PRESSURE (IN. WG)										
MOTOR SPEED		0.0	0.1	0.2	0.3	0.4	0.5	0.6	0.7	0.8	0.9	1.0
LOW	WATTS	157	155	152	148	-	-	-	-	-	-	-
	CFM	715	652	578	507	-	-	-	-	-	-	-
HIGH	WATTS	-	276	267	254	239	224	210	-	-	-	-
	CFM	-	1103	1043	967	864	737	600	-	-	-	-

Down Airflow

4TC*3018A1-DOWN		EXTERNAL STATIC PRESSURE (IN. WG)										
MOTOR SPEED		0.0	0.1	0.2	0.3	0.4	0.5	0.6	0.7	0.8	0.9	1.0
LOW	WATTS	158	156	152	147	-	-	-	-	-	-	-
	CFM	690	641	565	479	-	-	-	-	-	-	-
HIGH	WATTS	-	269	260	251	238	224	211	206	-	-	-
	CFM	-	1038	990	929	829	696	561	485	-	-	-

Indoor Fan Performance 4TC*3024A

Horizontal Airflow

4TC*3024A1-HOR		EXTERNAL STATIC PRESSURE (IN. WG)										
MOTOR SPEED		0.0	0.1	0.2	0.3	0.4	0.5	0.6	0.7	0.8	0.9	1.0
LOW	WATTS	210	206	199	190	180	170	-	-	-	-	-
	CFM	865	797	748	683	593	492	-	-	-	-	-
HIGH	WATTS	-	-	366	350	331	307	285	273	-	-	-
	CFM	-	-	1273	1179	1055	896	722	575	-	-	-

Down Airflow

4TC*3024A1-DOWN		EXTERNAL STATIC PRESSURE (IN. WG)										
MOTOR SPEED		0.0	0.1	0.2	0.3	0.4	0.5	0.6	0.7	0.8	0.9	1.0
LOW	WATTS	210	205	197	187	177	167	-	-	-	-	-
	CFM	825	780	730	659	563	453	-	-	-	-	-
HIGH	WATTS	-	-	357	341	326	310	294	276	-	-	-
	CFM	-	-	1181	1098	1002	881	729	550	-	-	-

Indoor Blower Performance

Indoor Fan Performance 4TC*3030B1

Horizontal Airflow

4TC*3030B1-HOR		EXTERNAL STATIC PRESSURE (IN. WG)										
MOTOR SPEED		0.0	0.1	0.2	0.3	0.4	0.5	0.6	0.7	0.8	0.9	1.0
LOW	WATTS	275	267	263	258	248	-	-	-	-	-	-
	CFM	992	930	881	823	746	-	-	-	-	-	-
MEDIUM	WATTS	350	342	334	324	311	296	280	-	-	-	-
	CFM	1164	1120	1067	1002	921	826	720	-	-	-	-
HIGH	WATTS	-	-	572	558	542	523	501	473	-	-	-
	CFM	-	-	1463	1390	1306	1210	1088	912	-	-	-

Down Airflow

4TC*3030B1-DOWN		EXTERNAL STATIC PRESSURE (IN. WG)										
MOTOR SPEED		0.0	0.1	0.2	0.3	0.4	0.5	0.6	0.7	0.8	0.9	1.0
LOW	WATTS	275	270	264	256	245	-	-	-	-	-	-
	CFM	974	910	861	800	716	-	-	-	-	-	-
MEDIUM	WATTS	352	341	332	323	312	298	283	-	-	-	-
	CFM	1151	1096	1039	977	903	812	698	-	-	-	-
HIGH	WATTS	-	-	574	552	533	517	498	466	-	-	-
	CFM	-	-	1434	1337	1243	1151	1036	842	-	-	-

Indoor Fan Performance 4TC*3036A

Horizontal Airflow

4TC*3036A-HOR		EXTERNAL STATIC PRESSURE (IN. WG)										
MOTOR SPEED		0.0	0.1	0.2	0.3	0.4	0.5	0.6	0.7	0.8	0.9	1.0
LOW	WATTS	351	342	335	327	314	-	-	-	-	-	-
	CFM	1154	1111	1067	1008	930	-	-	-	-	-	-
MEDIUM	WATTS	447	434	424	412	397	378	-	-	-	-	-
	CFM	1348	1301	1251	1189	1110	1012	-	-	-	-	-
HIGH	WATTS	-	-	675	658	640	619	594	563	-	-	-
	CFM	-	-	1545	1490	1418	1311	1169	1012	-	-	-

Down Airflow

4TC*3036A-DOWN		EXTERNAL STATIC PRESSURE (IN. WG)										
MOTOR SPEED		0.0	0.1	0.2	0.3	0.4	0.5	0.6	0.7	0.8	0.9	1.0
LOW	WATTS	349	341	331	319	305	-	-	-	-	-	-
	CFM	1138	1083	1017	948	878	-	-	-	-	-	-
MEDIUM	WATTS	450	433	420	407	392	374	-	-	-	-	-
	CFM	1325	1263	1200	1133	1058	970	-	-	-	-	-
HIGH	WATTS	-	-	669	652	631	605	579	562	-	-	-
	CFM	-	-	1517	1436	1336	1219	1095	980	-	-	-

Indoor Blower Performance

Indoor Fan Performance 4TC*3042B1

Horizontal Airflow

4TC*3042B1-HOR		EXTERNAL STATIC PRESSURE (IN. WG)										
MOTOR SPEED		0.0	0.1	0.2	0.3	0.4	0.5	0.6	0.7	0.8	0.9	1.0
LOW	WATTS	458	450	447	443	436	424	409	395	-	-	-
	CFM	1320	1290	1278	1266	1243	1205	1156	1104	-	-	-
MEDIUM	WATTS	544	542	535	526	515	503	487	463	426	-	-
	CFM	1501	1506	1490	1466	1440	1408	1362	1282	1143	-	-
HIGH	WATTS	-	633	621	610	595	574	548	519	492	-	-
	CFM	-	1705	1686	1663	1628	1578	1508	1416	1300	-	-

Down Airflow

4TC*3042B1-DWN		EXTERNAL STATIC PRESSURE (IN. WG)										
MOTOR SPEED		0.0	0.1	0.2	0.3	0.4	0.5	0.6	0.7	0.8	0.9	1.0
LOW	WATTS	455	447	443	438	430	417	402	388	-	-	-
	CFM	1328	1311	1290	1266	1239	1204	1151	1064	-	-	-
MEDIUM	WATTS	540	526	520	513	502	485	464	442	428	-	-
	CFM	1533	1506	1483	1457	1424	1379	1319	1240	1138	-	-
HIGH	WATTS	-	606	596	588	575	556	529	503	486	493	-
	CFM	-	1681	1654	1631	1594	1535	1455	1365	1284	1240	-

Indoor Fan Performance 4TC*3048A

Horizontal Airflow

4TC*3048A -HOR		EXTERNAL STATIC PRESSURE (IN. WG)										
MOTOR SPEED		0.0	0.1	0.2	0.3	0.4	0.5	0.6	0.7	0.8	0.9	1.0
LOW	WATTS	585	575	563	546	526	502	476	-	-	-	-
	CFM	1530	1520	1494	1455	1405	1343	1270	-	-	-	-
MED	WATTS	699	689	671	647	619	587	550	510	-	-	-
	CFM	1810	1783	1743	1691	1627	1548	1450	1325	-	-	-
HIGH	WATTS	-	966	944	914	878	837	794	753	721	-	-
	CFM	-	2217	2157	2086	1993	1874	1740	1611	1519	-	-

Down Airflow

4TC*3048A -DOWN		EXTERNAL STATIC PRESSURE (IN. WG)										
MOTOR SPEED		0.0	0.1	0.2	0.3	0.4	0.5	0.6	0.7	0.8	0.9	1.0
LOW	WATTS	573	565	547	524	503	483	462	-	-	-	-
	CFM	1533	1519	1478	1426	1372	1315	1248	-	-	-	-
MED	WATTS	677	659	639	615	589	561	531	498	-	-	-
	CFM	1771	1734	1688	1632	1567	1490	1398	1290	-	-	-
HIGH	WATTS	-	909	882	859	832	797	759	726	712	-	-
	CFM	-	2095	2024	1956	1873	1769	1651	1537	1456	-	-

Indoor Blower Performance

Indoor Fan Performance 4TC*3060A

Horizontal Airflow

4TC*3060A-HOR		EXTERNAL STATIC PRESSURE (IN. WG)										
MOTOR SPEED		0.0	0.1	0.2	0.3	0.4	0.5	0.6	0.7	0.8	0.9	1.0
LOW	WATTS	475	482	497	513	527	540	551	566	-	-	-
	CFM	1935	1888	1855	1826	1796	1762	1728	1698	-	-	-
MEDIUM	WATTS	602	639	656	665	675	689	706	722	729	-	-
	CFM	2081	2076	2051	2018	1987	1959	1934	1905	1860	-	-
HIGH	WATTS	-	-	775	789	802	816	831	844	854	856	-
	CFM	-	-	2173	2144	2114	2083	2050	2018	1990	1973	-

Down Airflow

4TC*3060A-DOWN		EXTERNAL STATIC PRESSURE (IN. WG)										
MOTOR SPEED		0.0	0.1	0.2	0.3	0.4	0.5	0.6	0.7	0.8	0.9	1.0
LOW	WATTS	498	510	523	536	548	560	573	589	-	-	-
	CFM	1902	1854	1827	1805	1777	1740	1697	1659	-	-	-
MEDIUM	WATTS	649	668	683	695	707	720	734	747	756	-	-
	CFM	2099	2063	2024	1989	1959	1934	1908	1874	1820	-	-
HIGH	WATTS	-	798	813	824	834	843	853	865	879	897	-
	CFM	-	2176	2150	2112	2076	2046	2021	1992	1943	1851	-

Typical Field Wiring

INTER-COMPONENT WIRING

-----	24V. LINE V.	} FACTORY WIRING
-----	24V. LINE V.	
=====	24V. LINE V.	} FIELD WIRING
=====	24V. LINE V.	

WIRE COLOR DESIGNATION			
ABBR	COLOR	ABBR	COLOR
BK	BLACK	PR	PURPLE
BL	BLUE	RD	RED
BR	BROWN	WH	WHITE
GR	GREEN	YL	YELLOW
OR	ORANGE		

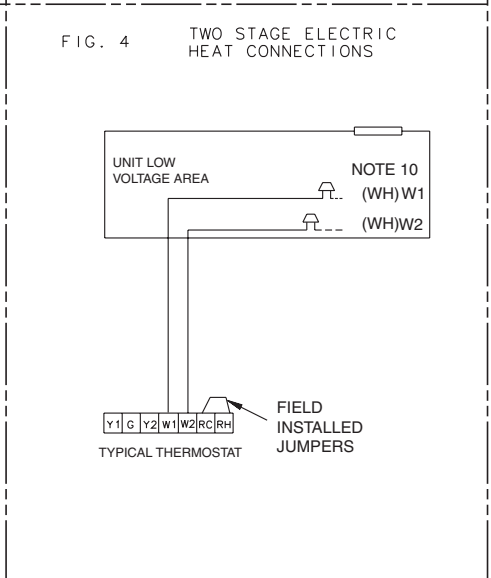
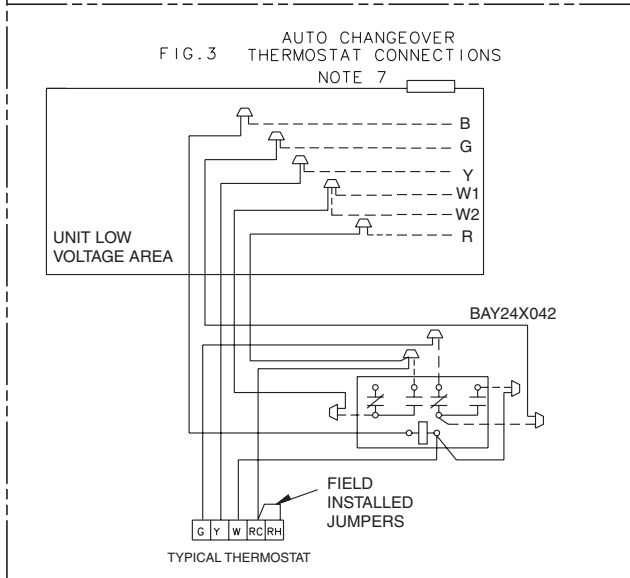
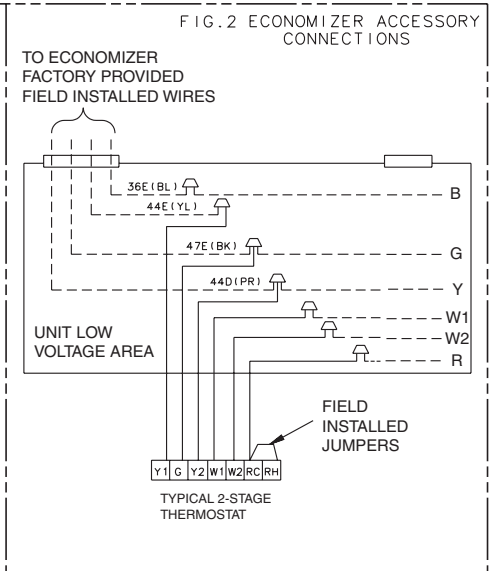
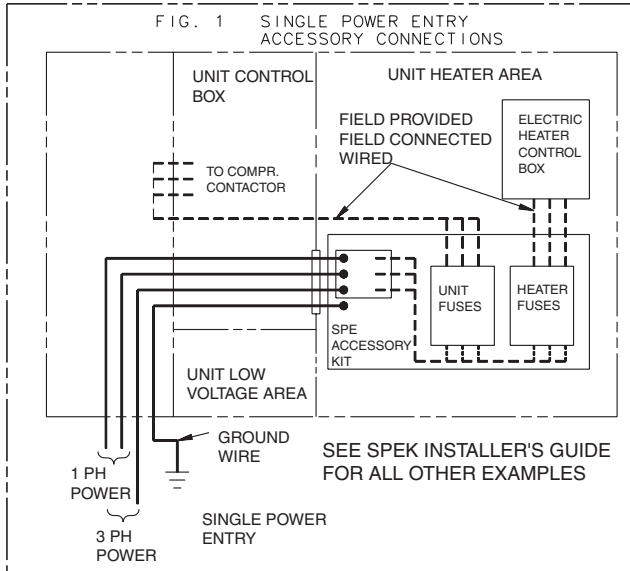
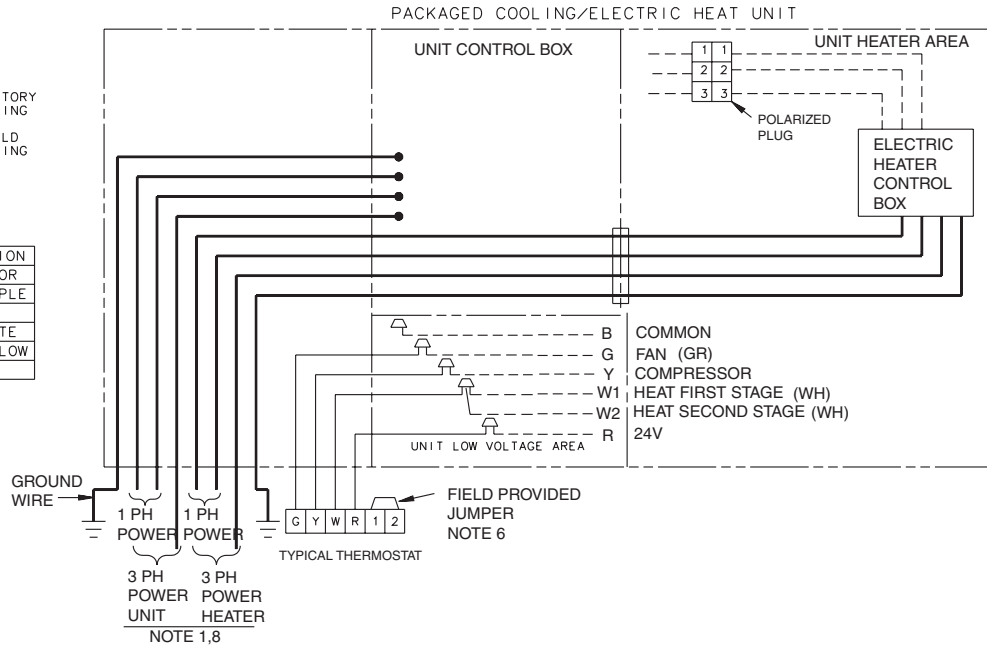

Typical wiring

Models 4TCX3018-060

See Service Facts for detailed wiring diagrams of the individual models

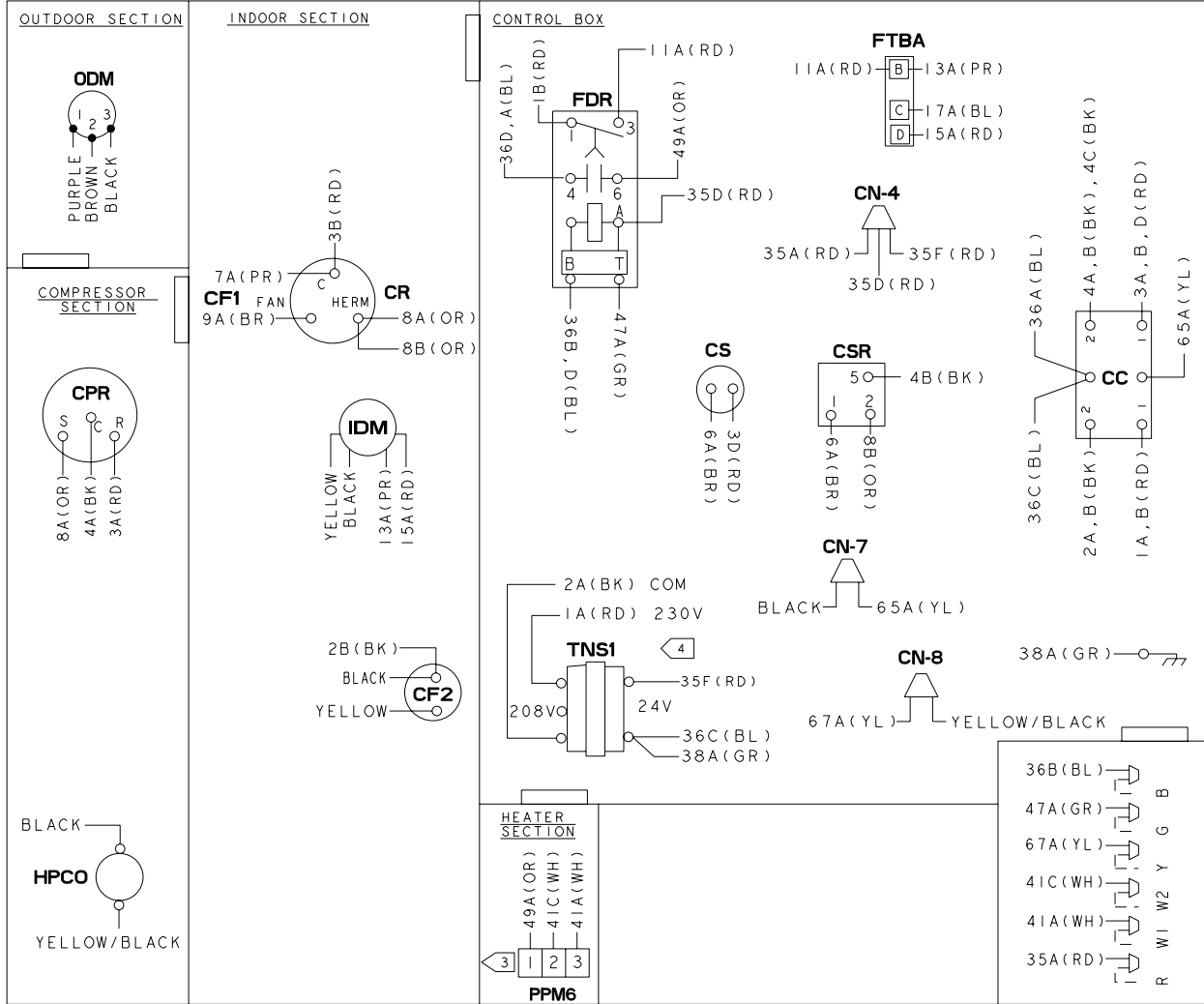

- NOTES:
- CONNECTIONS SHOWN ARE FOR A TYPICAL THERMOSTAT. SEE SCHEMATIC SUPPLIED WITH THERMOSTAT FOR PROPER CONNECTIONS. LOW VOLTAGE WIRING TO UNIT MAY BE NEC CLASS 2 AND MUST BE A MIN. OF 18 A.W.G.
 - MAXIMUM ADDITIONAL EXTERNAL LOAD (PILOT DUTY) BETWEEN "B" AND "R" OF 0.5 AMPS, 24 VAC IS AVAILABLE WHEN A HEATER IS INSTALLED.
 - SEE WIRING DIAGRAM WITH HEATER FOR DETAILS OF HEATER WIRING
 - FOR 208 VOLT OPERATION MAKE THE FOLLOWING WIRING CHANGES:
A: AT COMPRESSOR CONTACTOR REMOVE 1C(RD) WIRE FROM TNS1 AND CONNECT TO TNS1 AT 208V TERMINAL.
 - IF ANY OF THE ORIGINAL WIRE AS SUPPLIED IN THIS UNIT MUST BE REPLACED, REPLACE IT WITH APPLIANCE WIRING MATERIAL RATED AT 105° C.

ABBV	COLOR	ABBV	COLOR
BK	BLACK	PR	PURPLE
BL	BLUE	RD	RED
BR	BROWN	WH	WHITE
GR	GREEN	YL	YELLOW
OR	ORANGE		

DEVICE	DESCRIPTION	LINE
AH, BH	CONTACTOR, ELECTRIC HEAT	39, 40
CC	COMPRESSOR CONTACTOR COIL	43
CF1	OUTDOOR FAN CAPACITOR	19
CF2	INDOOR MOTOR CAPACITOR	26
CN	CONNECTOR OR WIRE NUT	
CPR	COMPRESSOR	18
CR	COMPRESSOR RUN CAPACITOR	19
CS	COMPRESSOR START CAPACITOR	15
CSR	COMPRESSOR START RELAY COIL	15
FDR	INDOOR FAN DELAY RELAY	44
FTB	FAN TERMINAL BLOCK	28, 29
IDM	INDOOR FAN MOTOR	28
IOL	INTERNAL OVERLOAD	
ODM	OUTDOOR FAN MOTOR	22
PCD	PRINTED CIRCUIT BOARD	45-47
PPM6	HEATER PLUG (FEMALE)	39, 40
TNS1	CONTROL POWER TRANSFORMER	34
HPCO	HIGH PRESSURE SWITCH	43

Optional Equipment

BAYCURB050A Full Perimeter Roof Mounting Curb for *****018-036

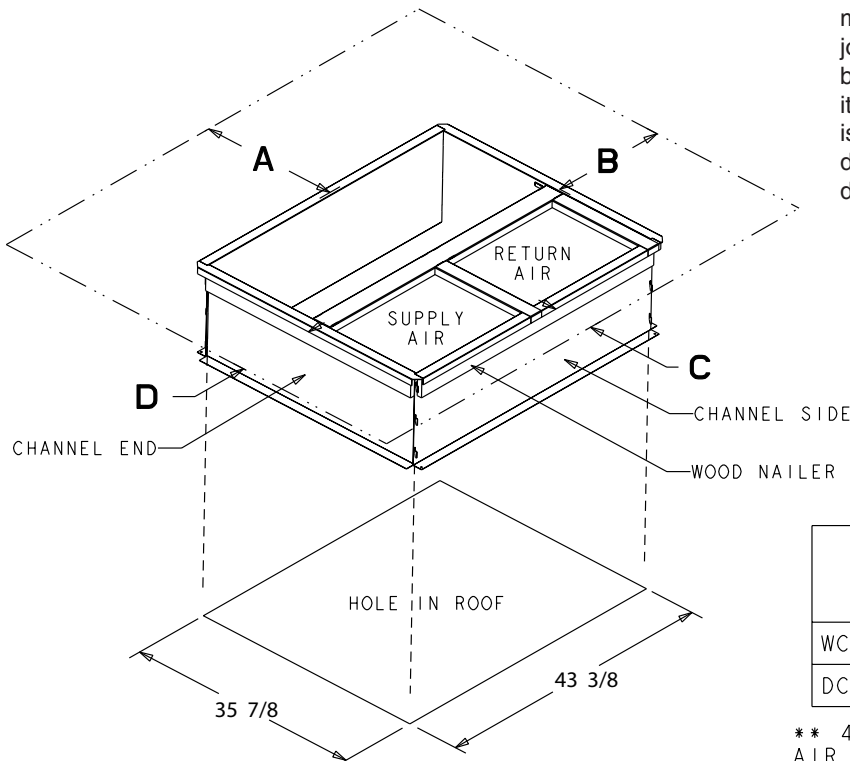
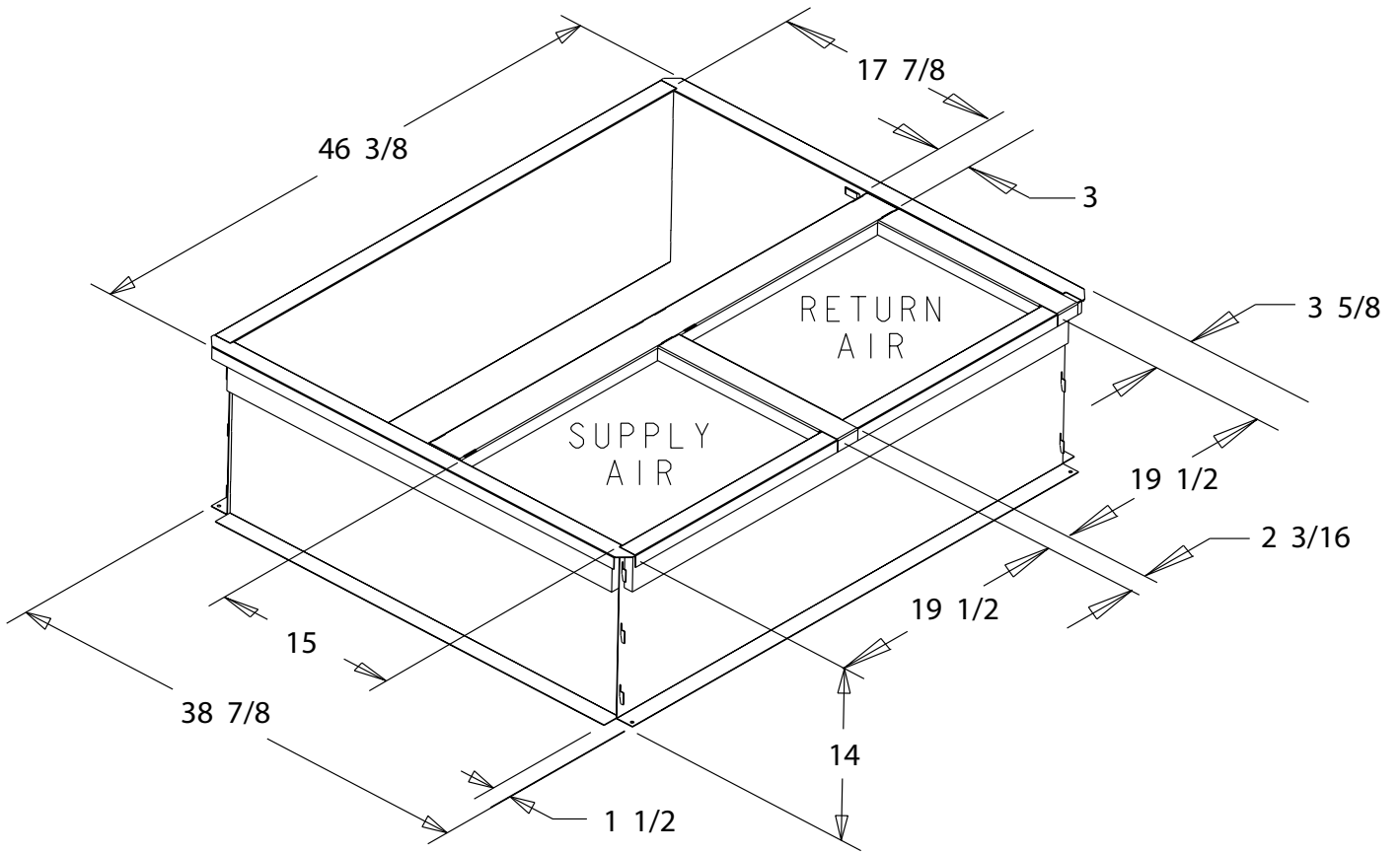

The drawings on this page are prepared by the manufacturer in order to provide detail regarding job layout only. These drawings are not intended to be used as a basis to construct, build or modify the items depicted in the drawings. The manufacturer is not responsible for the unauthorized use of these drawings and expressly disclaims any liability for damages resulting from such unauthorized use.

	SERVICE CLEARANCE DIMENSIONS			
	A	B	C	D
WC*/TC*	42.00	36.00	12.00**	24.00
DC*/YC*	42.00	36.00	12.00**	36.00

** 42.00 WITH ECONOMIZER WITH 25% FRESH AIR ACCESSORY

Optional Equipment

BAYCURB051A Full Perimeter Roof Mounting Curb for *****042-060

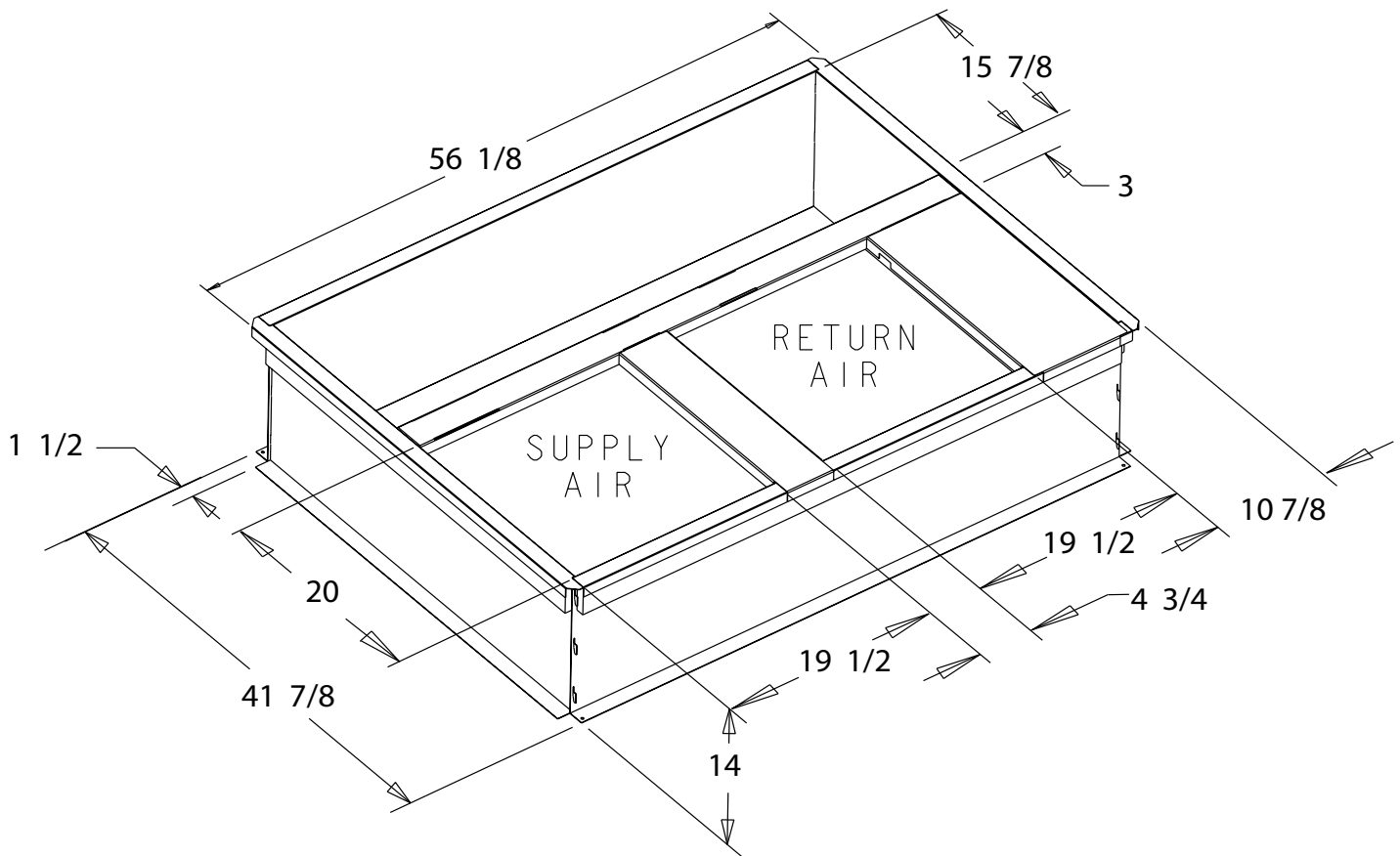

The drawings on this page are prepared by the manufacturer in order to provide detail regarding job layout only. These drawings are not intended to be used as a basis to construct, build or modify the items depicted in the drawings. The manufacturer is not responsible for the unauthorized use of these drawings and expressly disclaims any liability for damages resulting from such unauthorized use.

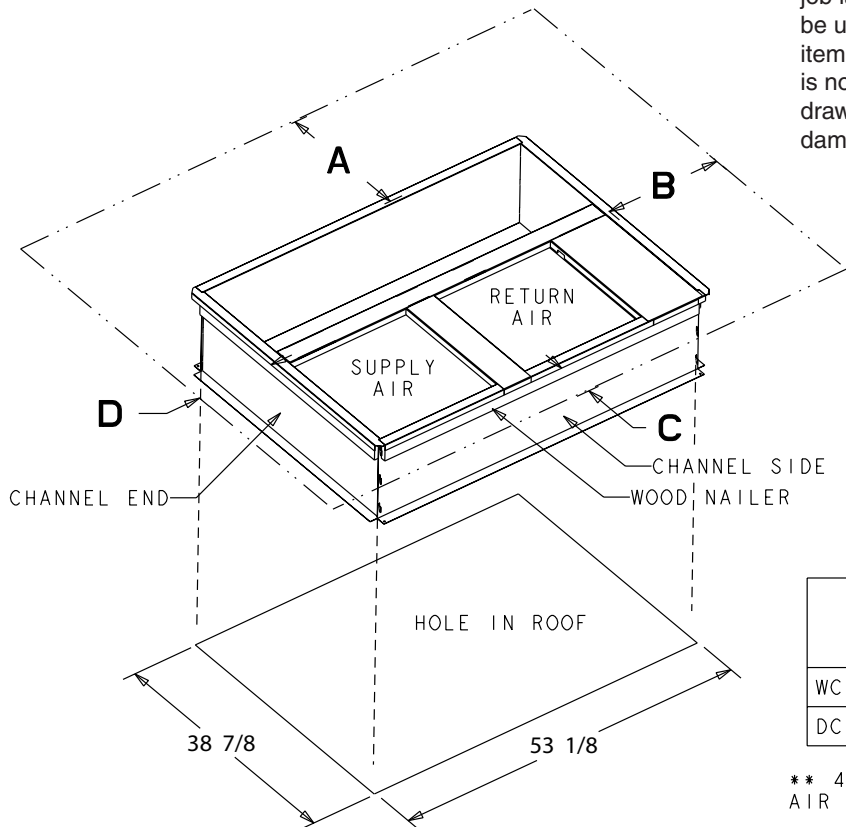

	SERVICE CLEARANCE DIMENSIONS			
	A	B	C	D
WC*/TC*	42.00	36.00	12.00**	24.00
DC*/YC*	42.00	36.00	12.00**	36.00

** 42.00 WITH ECONOMIZER WITH 25% FRESH AIR ACCESSORY

Optional Equipment

**BAYFLTR101, 201B, 1" - 2" Filter Rack
(Mounts in Filter/Coil Section)**

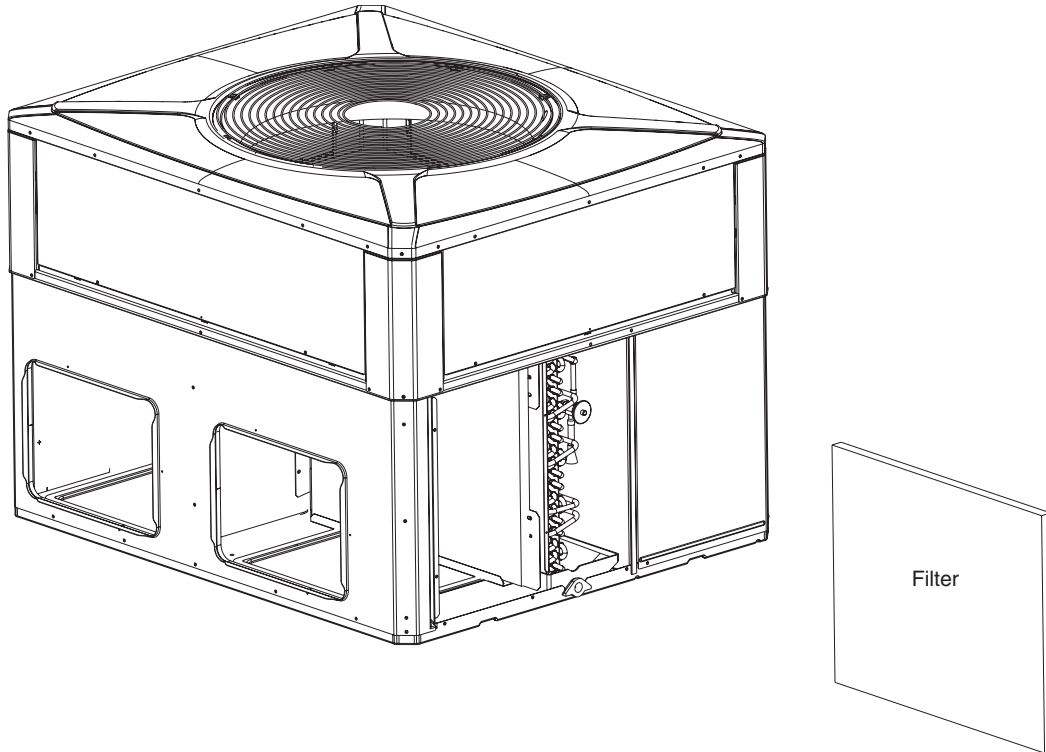

**BAYACCDOR1A & BAYACCDOR2A Hinged Filter Access Door
Replaces Filter/Coil Access Panel**

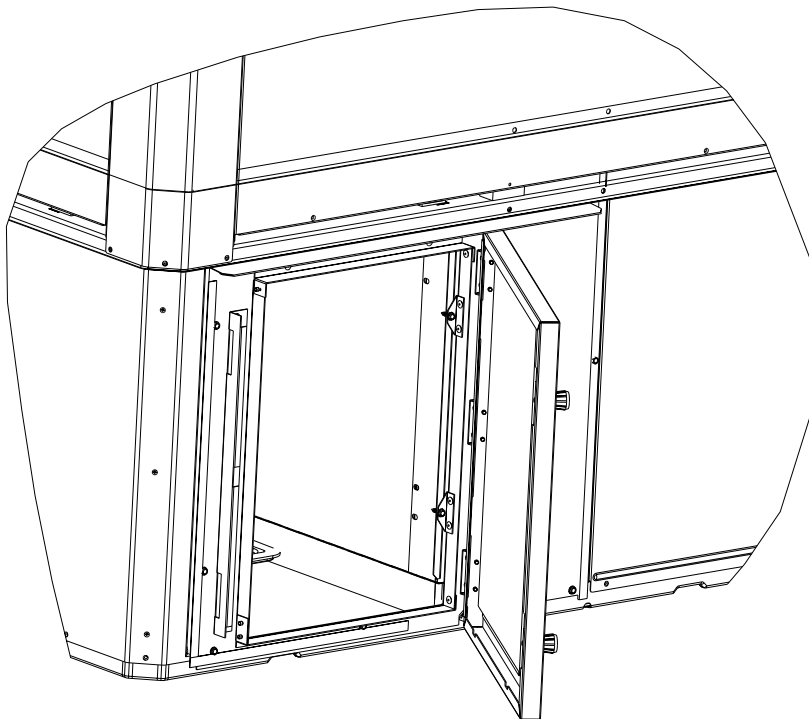

The drawings on this page are prepared by the manufacturer in order to provide detail regarding job layout only. These drawings are not intended to be used as a basis to construct, build or modify the items depicted in the drawings. The manufacturer is not responsible for the unauthorized use of these drawings and expressly disclaims any liability for damages resulting from such unauthorized use.

Optional Equipment

BAYECON101,102A Down Discharge Economizer and Rain Hood (Mounts Over Horizontal Return Air Opening)

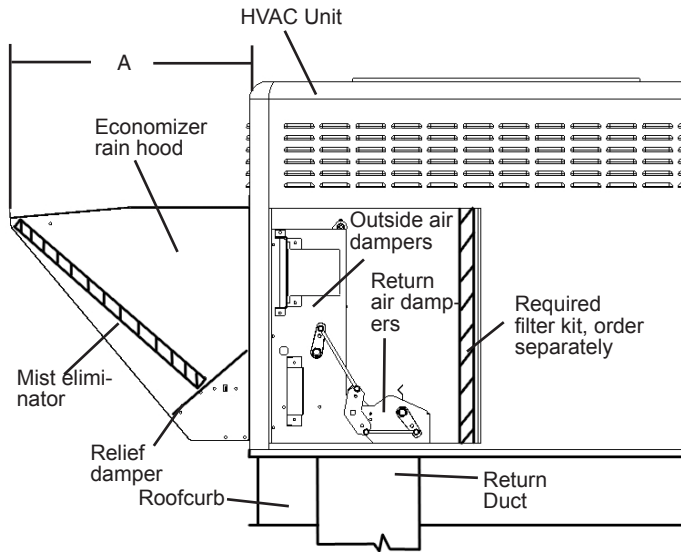

Economizer	Unit Application Models	A
BAYECON101A	4TC*,WC*,YC*,DC* *018-036	20.125"
BAYECON102A	4TC*,WC*,YC*,DC* *042-060	24.375"

BAYECON200,201A Horizontal Economizer and Rain Hood

The drawings on this page are prepared by the manufacturer in order to provide detail regarding job layout only. These drawings are not intended to be used as a basis to construct, build or modify the items depicted in the drawings. The manufacturer is not responsible for the unauthorized use of these drawings and expressly disclaims any liability for damages resulting from such unauthorized use.

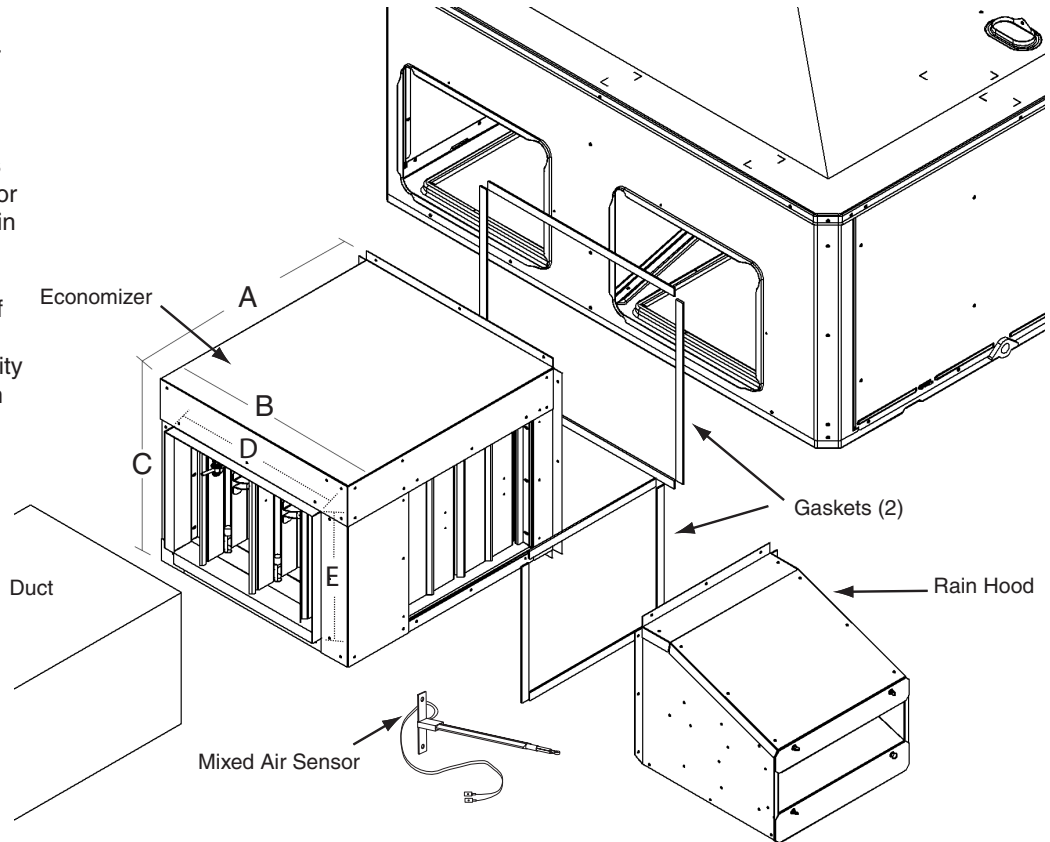

Economizer	A	B	C	D	E	F
BAYECON200AA	22"	20"	16 7/8"	15 11/16"	11 11/16"	15"
BAYECON201AA	26"	22 21/32"	19"	17 11/16"	14 11/16"	21-3/8"

Optional Equipment

BAYOSAH001,002A, 25% Outside Air Damper (Replaces Filter/Coil Access Panel)

The drawings on this page are prepared by the manufacturer in order to provide detail regarding job layout only. These drawings are not intended to be used as a basis to construct, build or modify the items depicted in the drawings. The manufacturer is not responsible for the unauthorized use of these drawings and expressly disclaims any liability for damages resulting from such unauthorized use.

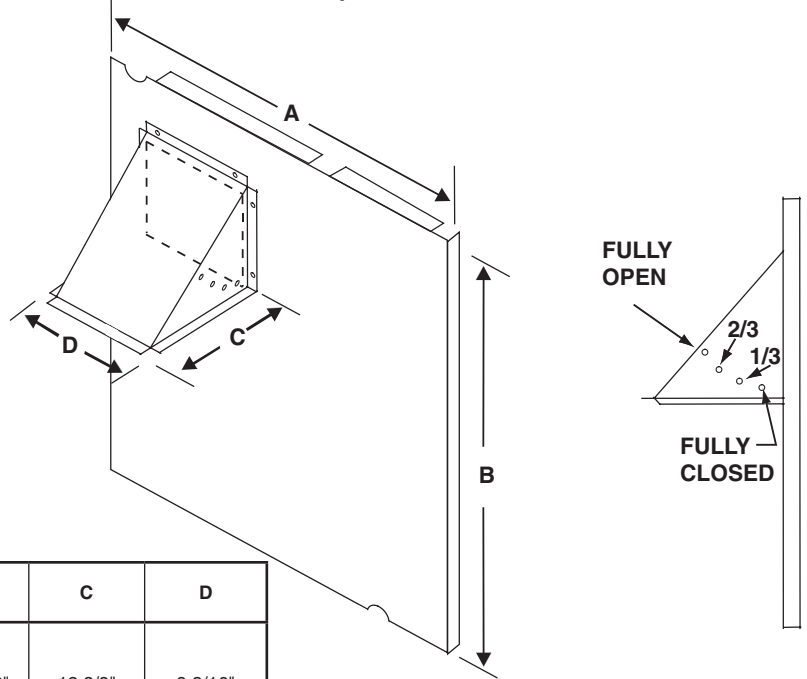

Manual Fresh Air Model	Unit Application Models	A	B	C	D
BAYOSAH001	4YC,WC3018-036 4TC*3018-036 4W/T/Y/DCY4024-036 4W/Y/DCZ6036	22 7/16"	20 11/16"	12 3/8"	9 3/16"
BAYOSAH002	4YC,WC3042-060 4TC*3042-060 4W/T/Y/DCY4042-060 4W/Y/DCZ6048-060	25 3/16"	20 11/16"	12 3/8"	9 3/16"

BAYDMPR101,102A, 25% Motorized Outside Air Damper (Mounts Over Horizontal Return Air Opening)

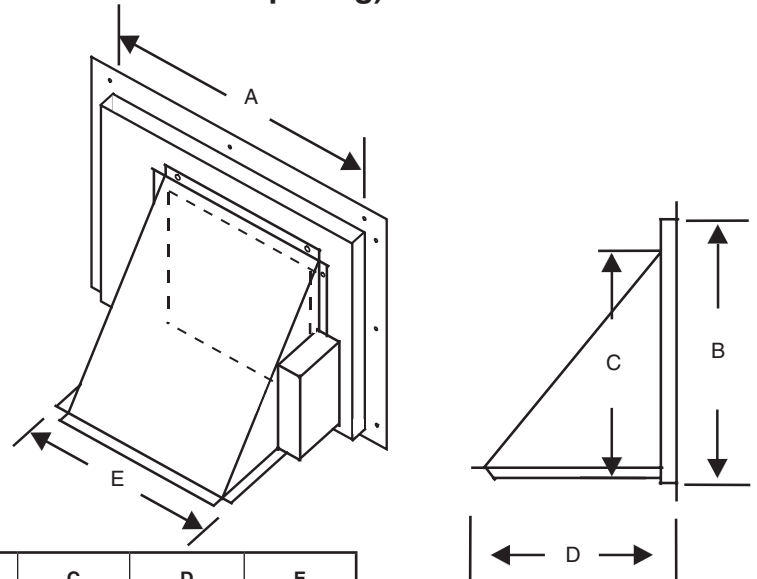

	Unit Application Models	A	B	C	D	E
BAYDMPR101A	4YC,WC3018-036 4TC3018-036 4W/T/Y/DCY4024-036 4W/Y/DCZ6036	15 13/16"	11 13/16"	10 1/4"	11 1/2"	12 1/4"
BAYDMPR102A	4YC,WC3042-060 4TC3042-060 4W/T/Y/DCY4042-060 4W/Y/DCZ6048-060	18 3/16"	15 1/8"	10 1/4"	11 1/2"	12 1/4"

Dimensional Data and Weights

NOTE: The view labeled "Bottom Side" represents the base as viewed looking up from underneath the unit.

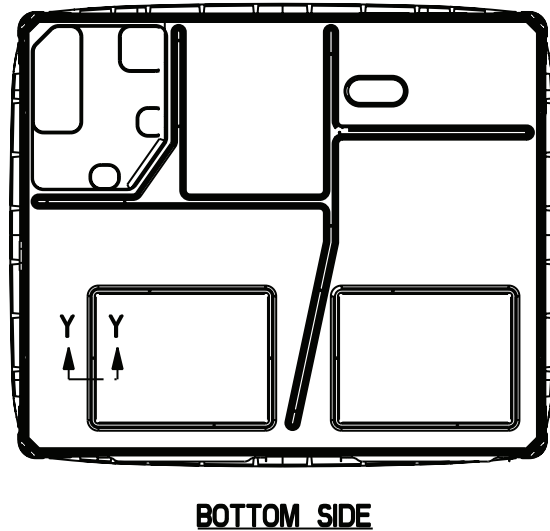
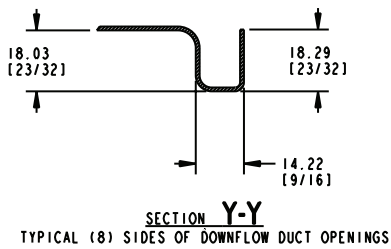
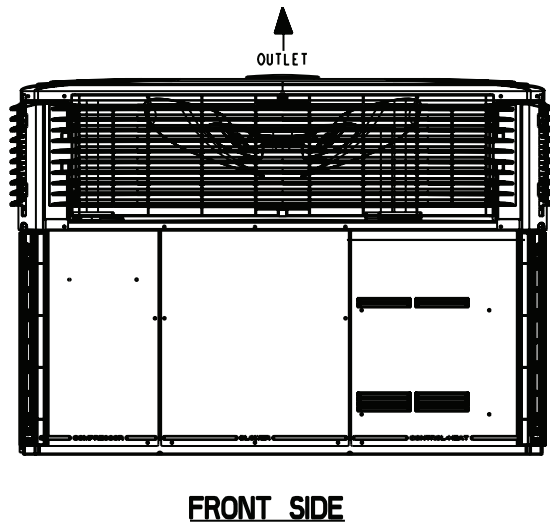
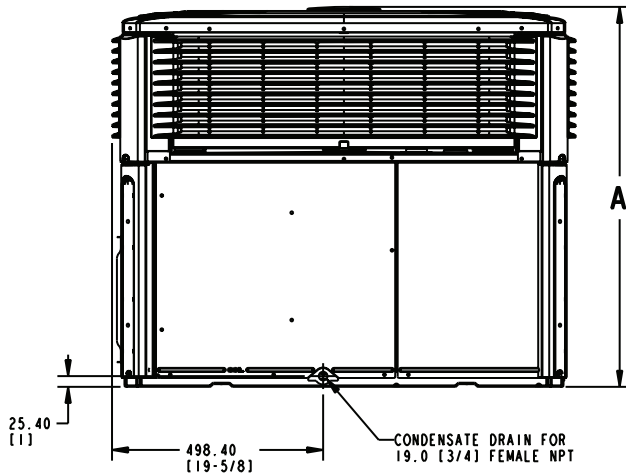
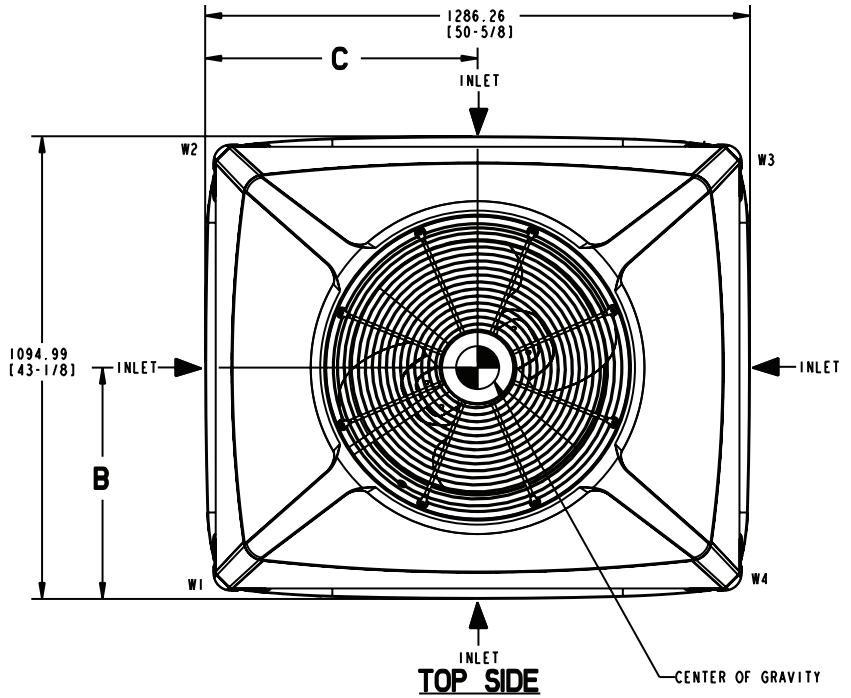

4TCX3018 through 4TCX3036 (1 of 3)

Dimensional Data and Weights

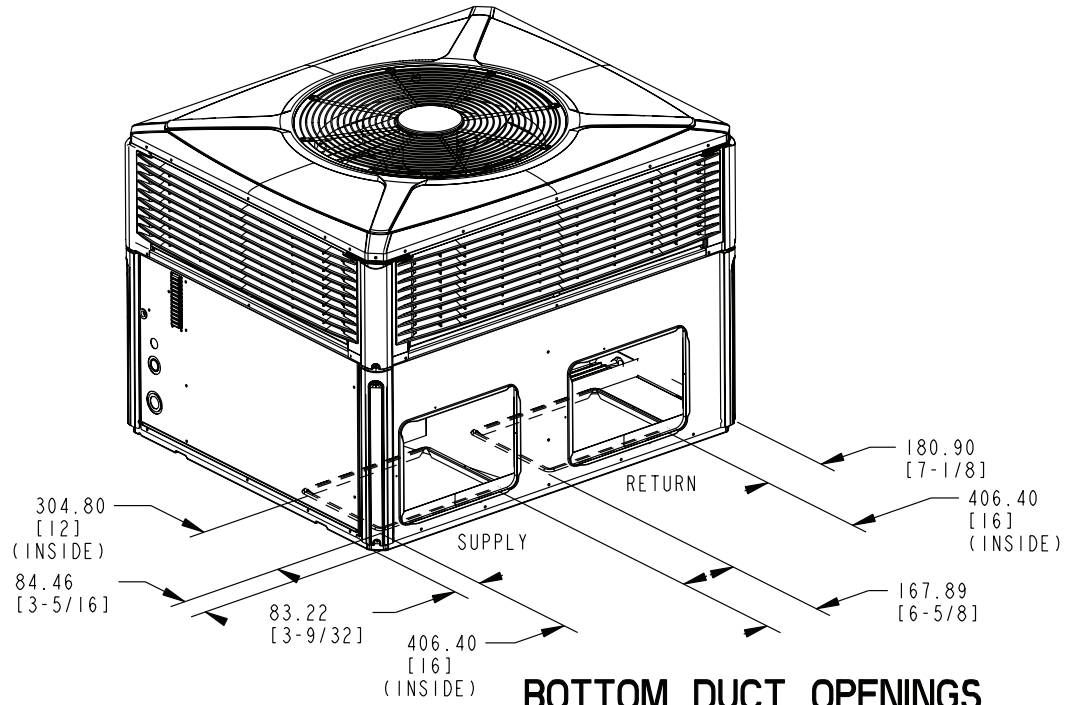

BOTTOM DUCT OPENINGS

RECOMMENDED SERVICE CLEARANCE MM/IN.		
		WITH ECONOMIZER
BACK SIDE	304.8 [12]	762.0 [30]
LEFT SIDE	762.0 [30]	914.4 [36]
RIGHT SIDE	609.6 [24]	-
FRONT SIDE	1066.8 [42]	-

CLEARANCE TO COMBUSTIBLE MATERIAL MM/IN.	
BOTTOM	0
BACK SIDE	25.4 [1]
LEFT SIDE	152.4 [6]
RIGHT SIDE	152.4 [6]
FRONT SIDE	304.8 [12]
TOP	914.4 [36]

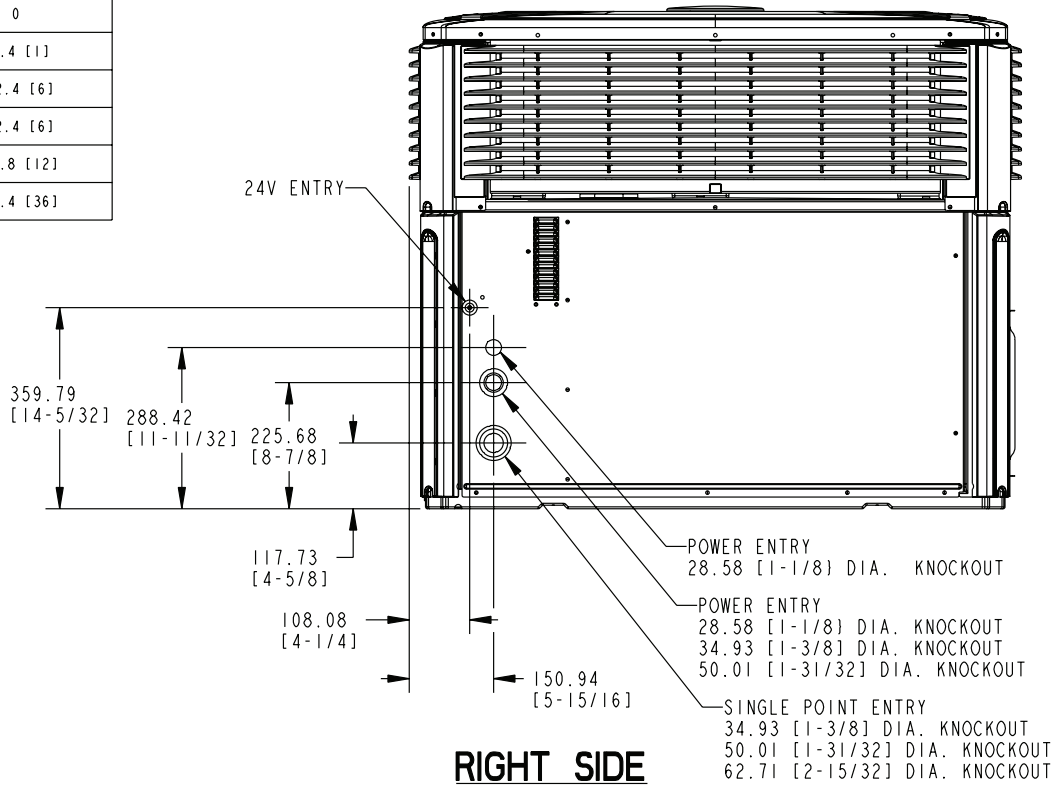

RIGHT SIDE

4TCX3018 through 4TCX3036 (2 of 3)

Dimensional Data and Weights

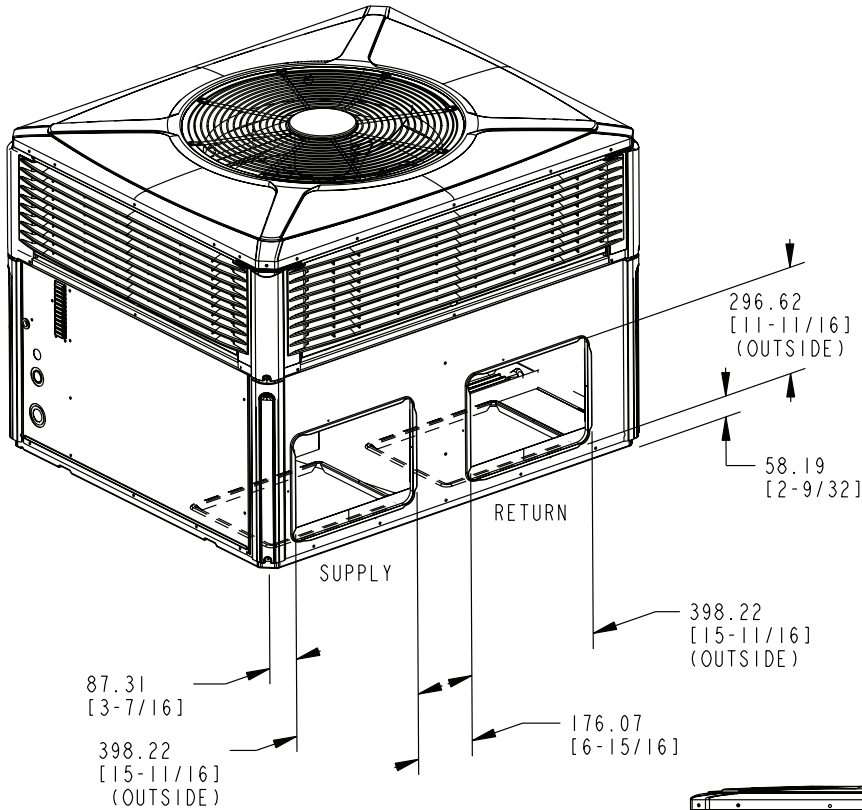

BACK DUCT OPENINGS

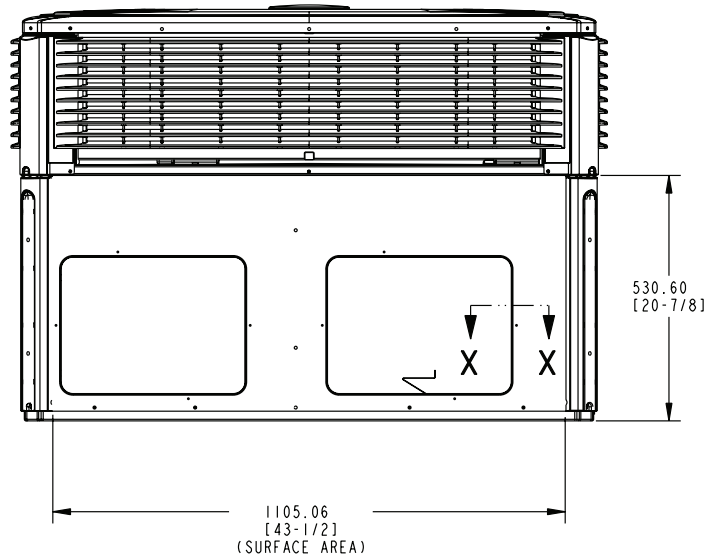
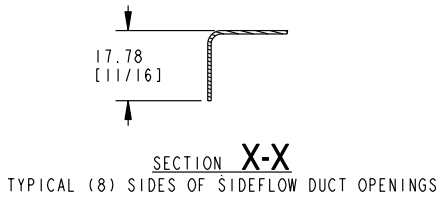

BACK SIDE

MODEL	HEIGHT MM/IN.	APPROX. CORNER WEIGHT - KG/LBS				SHIPPING WEIGHT KG/LBS	TOTAL UNIT WEIGHT KG/LBS	CENTER OF GRAVITY MM/IN.	
	A	W1	W2	W3	W4			B	C
4TCX3018	898.53 [35-3/8]	56.7 [125]	35.8 [79]	25.4 [56]	39.9 [88]	201.6 (444)	157.9 [348]	401.3 [15.8]	508.0 [20.0]
4TCX3024		56.7 [125]	35.8 [79]	25.4 [56]	39.9 [88]	201.6 (444)	157.9 [348]	401.3 [15.8]	508.0 [20.0]
4TCX3030		56.7 [125]	35.8 [79]	25.4 [56]	39.9 [88]	202.0 (445)	158.3 [349]	401.3 [15.8]	508.0 [20.0]
4TCX3036		57.6 [127]	36.3 [80]	25.9 [57]	40.8 [90]	204.3 (450)	160.6 [354]	401.3 [15.8]	508.0 [20.0]
4WCX3018		56.2 [124]	35.4 [78]	25.4 [56]	40.4 [89]	201.6 (444)	157.9 [348]	401.3 [15.8]	515.6 [20.3]
4WCX3024		57.6 [127]	36.3 [80]	26.3 [58]	41.7 [92]	205.7 [453]	161.9 [357]	401.3 [15.8]	515.6 [20.3]
4WCX3030		49.9 [110]	45.4 [100]	15.0 [33]	35.4 [78]	189.1 [417]	145.6 [321]	401.3 [15.8]	515.6 [20.3]
4WCX3036		60.8 [134]	38.1 [84]	27.2 [60]	42.6 [94]	212.5 (468)	168.7 [372]	401.3 [15.8]	508.0 [20.0]

4TCX3018 through 4TCX3036 (3 of 3)

Dimensional Data and Weights

NOTE: The view labeled "Bottom Side" represents the base as viewed looking up from underneath the unit.

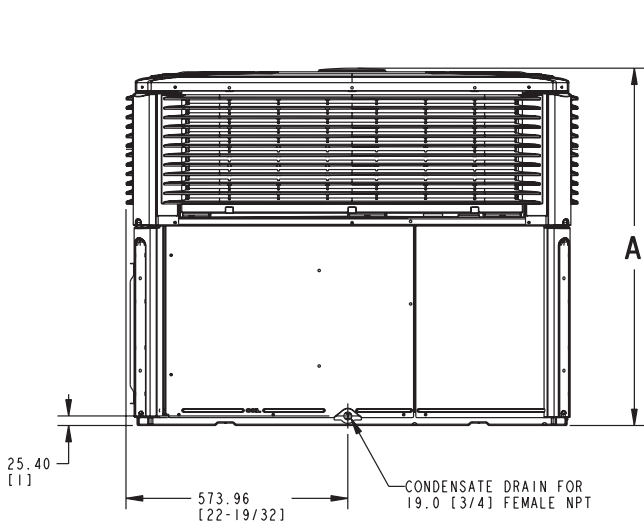
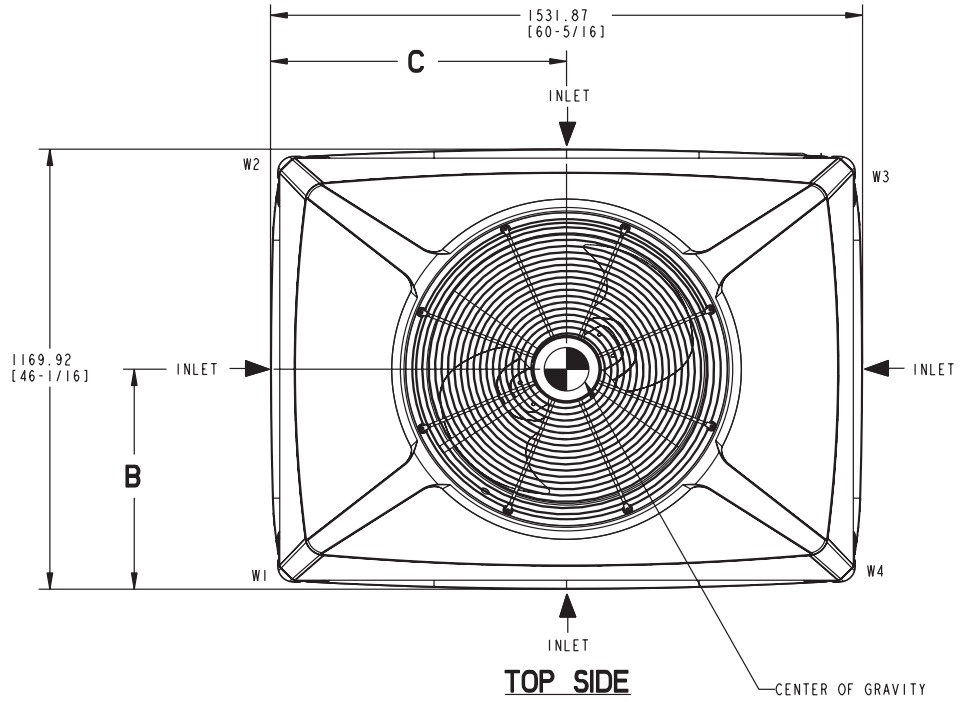

LEFT SIDE

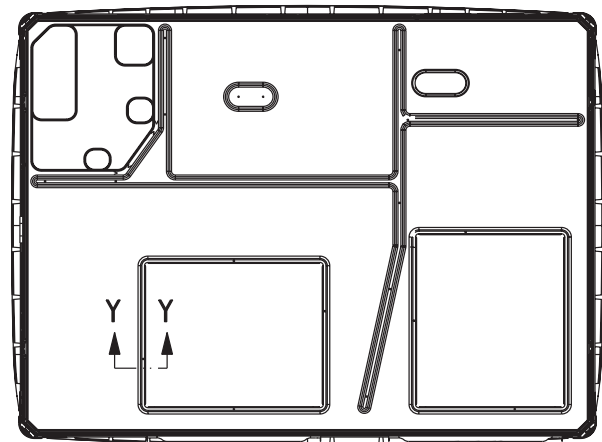
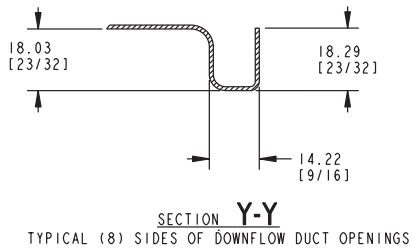
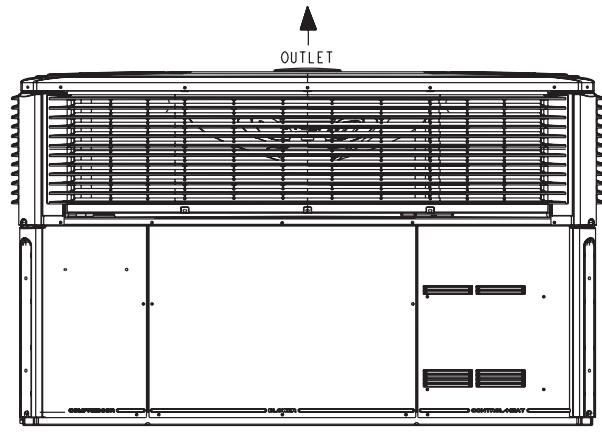

BOTTOM SIDE

4TCX3042 through 4TCX3060 (1 of 3)

Dimensional Data and Weights

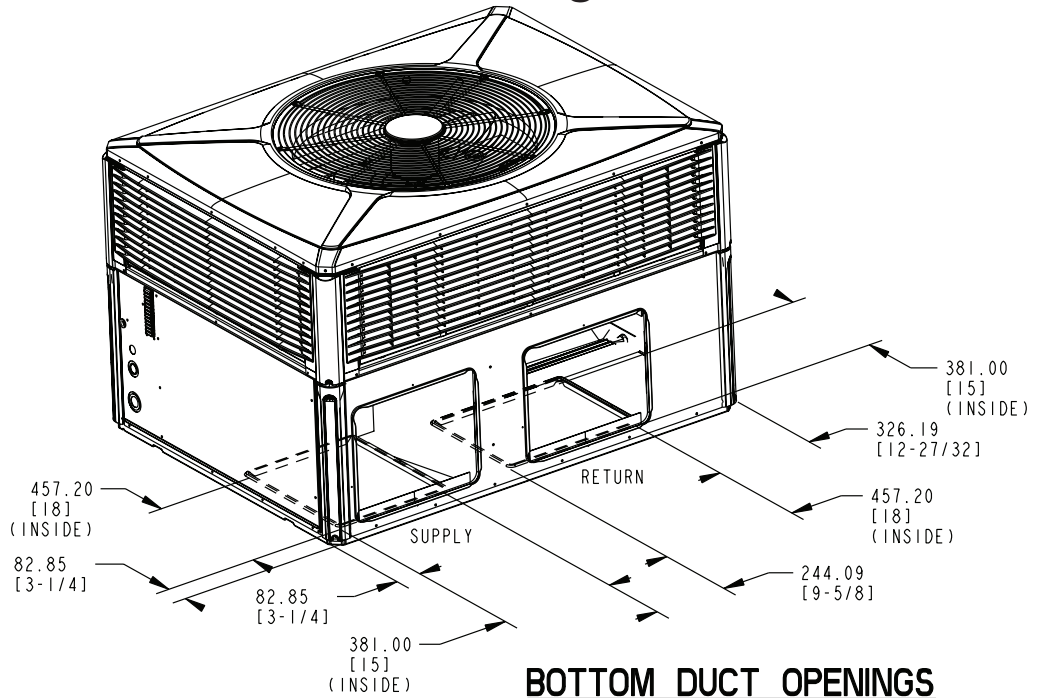

RECOMMENDED SERVICE CLEARANCE MM/IN.		
		WITH ECONOMIZER
BACK SIDE	304.8 [12]	762.0 [30]
LEFT SIDE	914.4 [36]	1066.8 [42]
RIGHT SIDE	609.6 [24]	-
FRONT SIDE	762.0 [30]	-

CLEARANCE TO COMBUSTIBLE MATERIAL MM/IN.	
BOTTOM	0
BACK SIDE	25.4 [1]
LEFT SIDE	152.4 [6]
RIGHT SIDE	152.4 [6]
FRONT SIDE	304.8 [12]
TOP	914.4 [36]

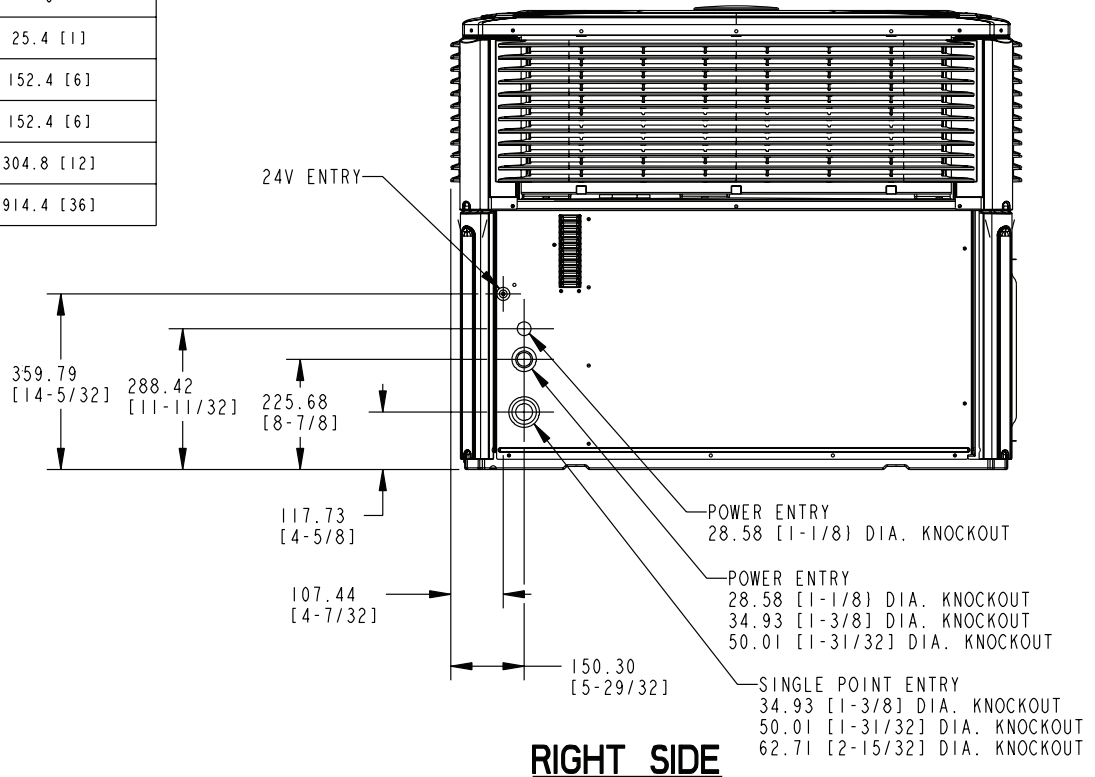

4TCX3042 through 4TCX3060 (2 of 3)

Dimensional Data and Weights

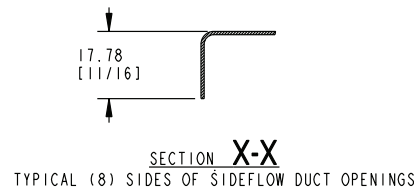
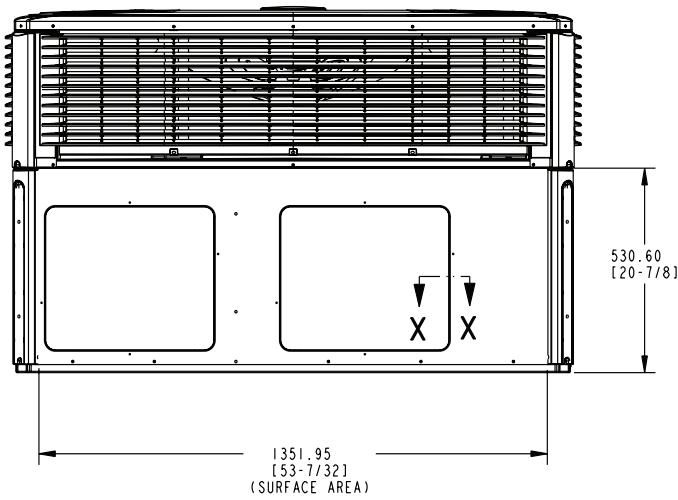
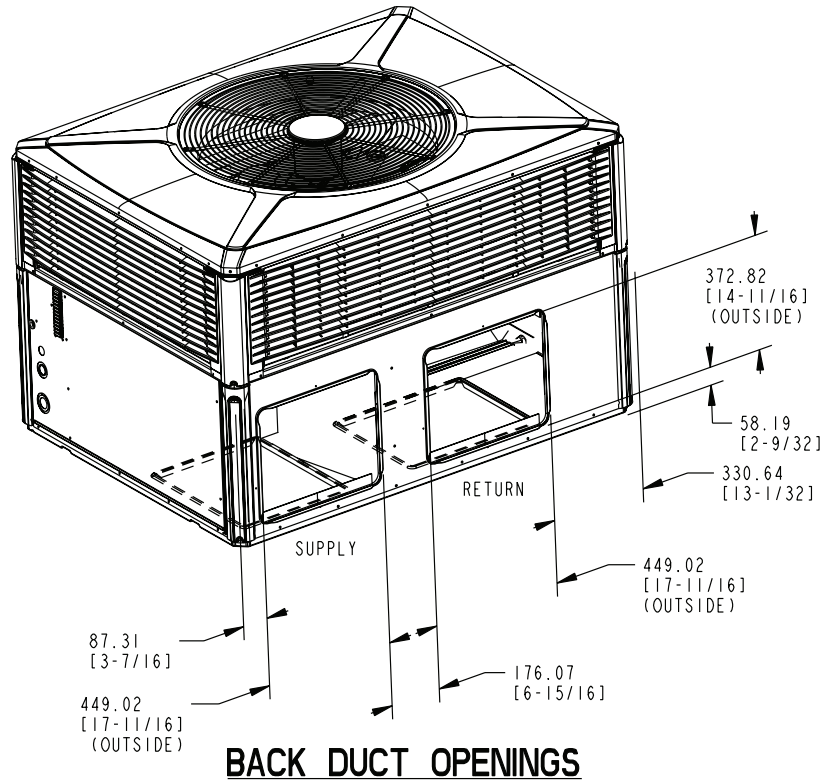

MODEL	HEIGHT MM/IN.	APPROX. CORNER WEIGHT - KG/LBS				SHIPPING WEIGHT KG/LBS	TOTAL UNIT WEIGHT KG/LBS	CENTER OF GRAVITY MM/IN.	
		A	W1	W2	W3			W4	B
4TCX3042	949.33 [37-3/8]	62.1 [137]	40.8 [90]	30.4 [67]	46.3 [102]	237.4 (523)	179.2 [395]	439.4 [17.3]	629.9 [24.8]
4TCX3048		76.2 [168]	47.6 [105]	35.8 [79]	57.6 [127]	275.6 (607)	217.3 [479]	426.7 [16.8]	635.0 [25.0]
4TCX3060	1000.13 [39-3/8]	78.0 [172]	46.3 [102]	34.9 [77]	59.0 [130]	276.9 (610)	218.6 [482]	414.0 [16.3]	635.0 [25.0]
4WCX3042	949.33 [37-3/8]	64.4 [142]	47.6 [105]	39.5 [87]	49.9 [110]	259.5 [572]	201.4 [444]	449.6 [177]	641.8 [25.3]
4WCX3048		68.9 [152]	40.8 [90]	30.8 [68]	52.2 [115]	251.1 (553)	192.8 [425]	414.0 [16.3]	635.0 [25.0]
4WCX3060	1000.13 [39-3/8]	79.4 [175]	47.2 [104]	35.8 [79]	59.9 [132]	280.6 (618)	222.3 [490]	414.0 [16.3]	635.0 [25.0]

4TCX3042 through 4TCX3060 (3 of 3)

Mechanical Specifications

General

The units shall be horizontal airflow as shipped and convertible to downflow. All units shall be factory assembled, piped, internally wired and fully charged with refrigerant. Units shall be certified to UL Standard 1995. All units shall be factory run tested to check cooling operation, fan and blower rotation and control sequence. Units shall be designed to operate at ambient temperatures between 115°F and 55°F in cooling as manufactured. Cooling performance shall be rated in accordance with AHRI standards.

Unit Casing

All panels shall be heavy gauge steel, gasketed and insulated. Foil-faced fiber insulation shall be in the heater section. Foil-faced fiber insulation shall be in the evaporator section. Base pan shall be heavy gauge steel. **WEATHERGUARD™** exterior corrosion resistant screws shall be used for added resistance to rust and corrosion.

Compressor

The compressor shall be a hermetically sealed, high efficiency Climatuff® compressor. Internal overcurrent and over temperature protection, internal pressure relief shall be standard. Other features include: centrifugal oil pump and low vibration and noise.

Refrigeration System

All units shall have refrigerant control. Service pressure tap ports, and a refrigerant line filter shall be standard.

Evaporator Coil — Internally enhanced 3/8-inch OD seamless copper tubing mechanically bonded to aluminum fins, factory pressure and leak tested at 250 to 300 psig. All units have TXV to control refrigerant flow.

Condenser Coil

The Spine Fin™ condenser coil shall be continuously wrapped, corrosion resistant all aluminum with minimum brazed joints. This coil is 3/8 inch O.D. seamless aluminum tubing glued to a continuous aluminum fin. Coils are lab tested to withstand 2,000 pounds of pressure per square inch. The outdoor coil provides low airflow resistance and efficient heat transfer. The coil is protected on all four sides by louvered panels.

Indoor Air Fan

Direct-drive, forward-curved, centrifugal wheel in a Composite Vortica® Blower housing. Motor shall have thermal overload protection. Permanently lubricated motor bearings. Motor/blower assembly isolated from unit with rubber mounts.

Outdoor Fan

One, direct-drive, statically and dynamically balanced propeller fan shall be used in a drawthrough vertical discharge configuration. Permanently lubricated weather proof motor shall have built-in thermal overload protection.

System Controls

System controls include condenser fan, evaporator fan and compressor contactors.

Accessories Roof Curb

The roof curb shall be designed to mate with the unit and provide support and complete weathertight installation when properly installed. Adhesive back polyurethane sealing strips shall be provided to ensure an airtight seal between supply and return openings of the curb and unit. The roof curb design allows field fabricated ductwork to be connected directly to the curb. Curb ships knocked down for field assembly, and includes factory-installed wood nailer strips.

Electric Heaters

Each heater assembly shall include power supply fusing if over 48 amps, automatic resetting limit switches and heat limiters for thermal protection. Heaters shall be provided with polarized plugs for quick connection to unit low voltage wiring. Electric heat modules shall be UL listed.

Single Source Power Entry

This accessory when used with electric heat accessory shall allow single source power connection to unit and heater combination. Single source power entry kits shall have specific matching heater(s). Kit shall include high voltage terminal blocks, fuse blocks and fuses, cut-to-length interconnecting wiring, and junction box (if required) to provide power sources with fuse protection as required for both the unit and accessory heater. Kit components shall install within the heater cabinet in the heater access section. Single source branch power circuit shall be protected and wired in accordance with local codes.

Fully Modulating Economizer

This accessory shall be field installed and be composed of the following items: 0-100% fresh air damper, damper drive motor, fixed dry bulb enthalpy control, and low voltage pigtailed for electrical connections. Solid state enthalpy or differential enthalpy control is optional. Economizer operations shall be controlled by the preset position of the enthalpy control. A barometric relief damper shall be standard with the downflow economizer and provide a pressure operated damper that shall be gravity closing and prohibit entrance of outside air on equipment "off" cycle.

Manual Outside Air Dampers

Rain hood and screen shall be field installed. Suitable for up to 25% outside air.

Start Kit - Extra compressor starting capacity for single phase equipment.

Control Options Standard Indoor Thermostats - Two stage heating/cooling or one stage heating/cooling thermostats shall be available in either manual or automatic changeover.

Programmable Electronic Night Setback Thermostat - Programmable electronic thermostat shall provide heating setback and cooling setup with 7-day, programming capability. 1 H/1 C or 2H/2C models available.

