



TRANE®

22-1799-15

Product Data

4DCY4024 through 4DCY4060

**Single Packaged Convertible Dual Fuel
14 SEER**

2 - 5 Ton, 40 - 120 MBTU

R-410A

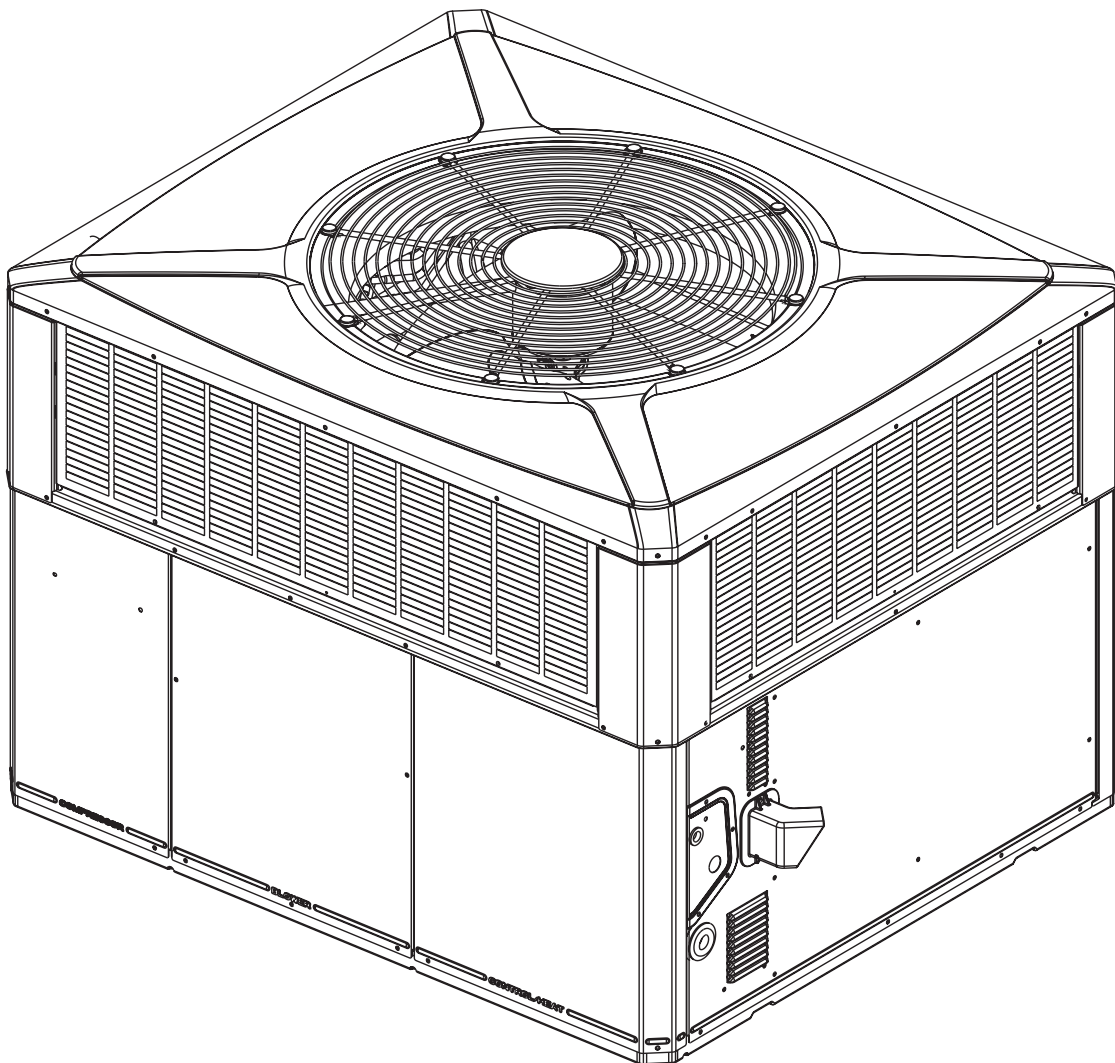

It's Hard to Stop a Trane.

Single Packaged Convertible Dual Fuel System

Trane offers a complete family of dual fuel heating and cooling systems, designed to keep you comfortable all year long, regardless of the weather, while keeping your operating costs as low as possible. The heat pump operates efficiently as both an air conditioner and a heater. In the summer, the heat pump cools your home just like any other air conditioner by pulling the heat from the inside and releasing it outdoors. In the winter, it captures the heat that is always present in the outdoor air and transfers it indoors. The gas furnace provides additional heating capacity for cooler weather.

Introducing the new TRANE Single Packaged Convertible Dual Fuel System.

Single Packaged Convertible Dual Fuel Systems are easy and versatile to install. Because cooling and heating functions are all contained in a single cabinet, a Trane packaged dual fuel system is easy to install and service. It can be flush mounted beside your home at ground level or placed on the roof for horizontal or downflow installation. When connected to a *CONT402, 802, or 803 comfort control, and air distribution ducts, you have a highly efficient, total home comfort system.

Single Packaged Dual Fuel Systems are unmatched in quality and reliability. All major components on these products, including the compressor, have been designed and manufactured for maximum service. Every Climatuff® compressor is designed and manufactured to exacting specifications. Each design is life tested in extreme environments to ensure reliable and long lasting operation in normal applications. Each compressor has internal motor protection for added reliability.

Contents

Optional Equipment Listing	4
<hr/>	
General Data	5
<hr/>	
Indoor Blower Performance	8
<hr/>	
Typical Wiring	16
<hr/>	
Optional Equipment	14
<hr/>	
Dimensional Data	19
<hr/>	
Mechanical Specifications	25
<hr/>	

Optional Equipment Listing

OPTIONAL EQUIPMENT FOR 4DCY4 PACKAGED UNITS (check mark [✓] indicates accessories included)

Hinged Filter Access Door (4DCY4024-036) ⑧	BAYACCDOR1A[]
Hinged Filter Access Door (4DCY4042-060) ⑧	BAYACCDOR2A[]
Roof Curb Full Perimeter (4DCY4024-036) ③	BAYCURB050A[]
Roof Curb Full Perimeter (4DCY4042-060) ③	BAYCURB051A[]
Roof Curb Utility Extension Kit (BAYCURB050A)	BAYUTIL101B[]
Roof Curb Utility Extension Kit (BAYCURB051A)	BAYUTIL102B[]
0-25% Manual Fresh Air Damper (4DCY4024-36) ①	BAYOSAH001A[]
0-25% Manual Fresh Air Damper (4DCY4042-060) ①	BAYOSAH002A[]
Motorized Fresh Air Damper (4DCY4024-36) ①	BAYDMPR101A[]
Motorized Fresh Air Damper (4DCY4042-060) ①	BAYDMPR102A[]
16" Round Duct Adapter (2 per box) (4DCY4024-36) ⑥	BAYSQRD001A[]
18" Round Duct Adapter (2 per box) (4DCY4024-060) ⑥	BAYSQRD002A[]
0-100% Mod Economizer w/Baro. Relief (4DCY4024-36) ①②④	BAYECON101B[]
0-100% Mod. Economizer w/Baro. Relief (4DCY4042-060) ①②④	BAYECON102B[]
0-100% Horizontal Economizer (4DCY4024-36) ①②	BAYECON200A[]
0-100% Horizontal Economizer (4DCY4042-060) ①②	BAYECON201A[]
Economizer Relay Kit (required for Heat Pump applications)	BAYRLAY004A[]
Enthalpy Control for Economizer (solid state)	BAYENTH001A[]
Remote Potentiometer (All-BAYECON***A)	BAYSTAT023[]
1"-2" Filter Frame (4DCY4024-36) (20 x 25 filter not included) ①	BAYFLTR101B[]
1"-2" Filter Frame (4DCY4042-60) (20 x 20 & 20 x18 filter not included) ①	BAYFLTR201B[]
Head Pressure Control (Low Ambient Cool) (208/240v) Kit ⑤	BAYLOAM105A[]
Quick Start Kit (4DCY4-†1)	BAYQSKT300A[]
Crankcase Heater Recip (4DCY4024†1 (230v) ⑤	BAYCCHT101A[]
Crankcase Heater Scroll(4DCY4036,48, 60†1/3)(230v) ⑤	BAYCCHT102A[]
Adapter Curb 4DCY4024-36 to BAYCURB030,38	BAYADAP050A[]
Adapter Curb 4DCY4024-36 to BAYCURB033	BAYADAP051A[]
Adapter Curb 4DCY4042-60 to BAYCURB030,38	BAYADAP052A[]
Adapter Curb 4DCY4042-60 to BAYCURB033	BAYADAP053A[]
Adapter Curb 4DCY4042-60 to BAYCURB034	BAYADAP054A[]
12" Duct Shroud Covers Horizontal *DCY4024-60⑦	BAYCOVR112A[]
18" Duct Shroud Covers Horizontal *DCY4024-60 ⑦	BAYCOVR118A[]
Extreme Condition Mounting Kit - All BAYCURB & BAYADAP	BAYEXMK001A[]
Extreme Condition Mounting Kit - All BAYUTIL	BAYEXMK002B[]
Extreme Condition Mounting Kit - All Slab Mounts	BAYEXMK003A[]
Lifting Lug Kit	BAYLIFT002B[]
LP Conversion Kit (All 40K, 120K Models)	BAYLPKT100A[]
LP Conversion Kit (All 64K, 96K Models)	BAYLPKT101A[]
LP Conversion Kit (All 75K Models)	BAYLPKT102A[]

- NOTES: ① Must use internal filter frame when economizer or fresh air kit is used.
 ② Dry bulb control standard with economizer.
 ③ Ships knocked down.
 ④ Downflow only.
 ⑤ Low Ambient cooling requires crankcase heater (BAYCCHT----A).
 ⑥ It is the responsibility of the installing dealer to properly size the ductwork for each specific application.
 ⑦ BAYCOVR112,118A will not cover BAYSQRD002A applications.
 ⑧ BAYACCDOR1A requires BAYFLTR101B & BAYACCDOR2A requires BAYFLTR201B. They are not backward compatible to BAYFLTR101/201A.
 † = A or B

General Data

MODEL	4DCY4024A1064B	4DCY4030A1075B	4DCY4036B1075A
RATED Volts/PH/Hz	208-230/1/60	208-230/1/60	208-230/1/60
Performance Cooling BTUH ^①	23600	30000	37400
Indoor Airflow (CFM)	760	880	1185
Power Input (KW)	2.162	2.15	3.11
EER/SEER(BTU/Watt-Hr.) ^⑤	12/14.0	12.0 / 14.25	12.0 / 14.0
Sound Power Rating [dB(A)] ^⑦	68	71	69
HP Heating Performance			
(High Temp.)BTUH / COP	22400 / 3.7	28000 / 3.9	37400 / 3.7
Power Input (KW)	1.77	2.15	2.9
(Low Temp.) BTUH / COP	11600 / 2.38	15400 / 2.48	22400 / 2.5
Power Input (KW)	1.24	1.81	2.5
HSPF (BTU / Watt-Hr.)	8.0	8.0	8.0
Gas Heating Performance ^②			
(High) Input BTUH	64000	75000	75000
Capacity BTUH	51500	60500	60500
Temp. Rise — Min/Max (°F)	35 / 65	30 / 60	30 / 60
(Low) Input BTUH	48000	56250	56250
Capacity BTUH	41200	48400	48400
AFUE	79	79.5	79.5
Type of Gas ^③	NATURAL	NATURAL/LP	NATURAL
Gas Pipe Size (in.)	1/2	1/2	1/2
POWER CONN.—V/PH/Hz	208-230/1/60	208-230/1/60	208-230/1/60
Min. Brch. Cir. Ampacity ^④	16.1	19.1	24.6
Fuse Size — Max. (amps)	25	30	40
Fuse Size — Recmd. (amps)	25	30	40
COMPRESSOR	RECIPROCATING	RECIPROCATING	SCROLL
Volts/Ph/Hz	208-230/1/60	200-230/1/60	208-230/1/60
R.L. Amps — L.R. Amps	8.3 / 57.8	11.1 / 63	15.4 / 83
OUTDOOR COIL — TYPE	SPINE-FIN	SPINE-FIN	SPINE-FIN
Rows/F.P.I.	2 / 24	2 / 24	2 / 24
Face Area (sq.ft.)	13.32	13.32	15.49
Tube Size (in.)	3/8	3/8	3/8
Refrigerant Control	EXPANSION VALVE	EXPANSION VALVE	EXPANSION VALVE
INDOOR COIL — TYPE	PLATE FIN	PLATE FIN	PLATE FIN
Rows/F.P.I.	3 / 15	4 / 15	4 / 15
Face Area (sq.ft.)	3.54	3.54	3.54
Tube Size (in.)	3/8	3/8	3/8
Refrigerant Control	EXPANSION VALVE	EXPANSION VALVE	EXPANSION VALVE
Drain Conn. Size (in.)	3/4 FEMALE NPT	3/4 FEMALE NPT	3/4 FEMALE NPT
OUTDOOR FAN — TYPE	PROPELLER	PROPELLER	PROPELLER
Dia. (in.)	23.4	23.4	23.4
Drive/No. Speeds	DIRECT / 1	DIRECT / 1	DIRECT / 1
CFM @ 0.0 in. w.g. ^⑧	2590	3250	3310
Motor — HP/R.P.M.	1/12 / 810	1/6 / 830	1/5 / 830
Volts/Ph/Hz	208-230/1/60	208-230/1/60	208-230/1/60
F.L. Amps/L.R. Amps	0.54 / 0.95	1.0 / 1.7	1.1 / 1.9
INDOOR FAN — TYPE	CENTRIFUGAL	CENTRIFUGAL	CENTRIFUGAL
Dia x Width (in.)	10 X 10	10 X 10	10 X 10
Drive/No. Speeds	DIRECT / VARIABLE	DIRECT / VARIABLE	DIRECT / VARIABLE
CFM @ 0.0 in. w.g. ^⑧	SEE FAN PERFORMANCE TABLE	SEE FAN PERFORMANCE TABLE	SEE FAN PERFORMANCE TABLE
Motor — HP/R.P.M.	1/2 / VARIABLE	1/2 / VARIABLE	1/2 / VARIABLE
Volts/Ph/Hz	200-230/1/60	208-230/1/60	200-230/1/60
F.L. Amps/L.R. Amps	4.3 / 4.3	4.3 / 4.3	4.3 / 4.3
COMBUSTION FAN — TYPE	CENTRIFUGAL	CENTRIFUGAL	CENTRIFUGAL
Drive/No. Speeds	DIRECT / 2	DIRECT / 2	DIRECT / 2
Motor — HP/R.P.M. (High/Low)	1/45 / 2800/1500	1/45 / 2800/1500	1/45 / 2800/1500
Volts/Ph/Hz	208-230/1/60	208-230/1/60	208-230/1/60
FLA	0.34	0.34	0.34
FILTER / FURNISHED	NO	NO	NO
Type Recommended	THROWAWAY	THROWAWAY	THROWAWAY
Recmd. Face Area (sq. ft.) ^⑥	4	4	4
REFRIGERANT / Charge (lbs.)	R410A / 6.5	R410A / 6.56	R410A / 7.5
DIMENSIONS	H X W X L	H X W X L	H X W X L
Crated (in.)	45.86 / 44.5 / 52.03	45.86 / 44.5 / 52.03	47.86 / 44.5 / 52.03
WEIGHT / Shipping / Net (lbs.)	481 / 385	481 / 385	488 / 392

① Certified in accordance with the Unitary Air-Conditioner Equipment certification program, which is based on AHRI Standard 210/240.

② All models are U L Listed. Ratings shown are for elevations up to 2000 ft. For higher elevations reduce ratings at a rate of 4% per 1000 ft. elevation.

③ Convertible to LPG.

④ This value is approximate. For more precise value, see Unit Nameplate.

⑤ Based on U.S. Government Standard Tests.

⑥ Filters must be installed in return air stream. Square footages listed are based on 300 f.p.m. face velocity. If permanent filters are used size per manufacturer's recommendation with a clean resistance of 0.05" W.C.

⑦ Sound Power values are not adjusted for AHRI 270-95 tonal corrections.

⑧ Standard Air — Dry Coil — Outdoor.

General Data

MODEL	4DCY4036A3075A	4DCY4042A1096A	4DCY4048B1096B
RATED Volts/PH/Hz	208-230/3/60	208-230/1/60	208-230/1/60
Performance Cooling BTUH^①	36000	42000	47500
Indoor Airflow (CFM)	1185	1370	1470
Power Input (KW)	3.284	3.27	3.96
EER/SEER(BTU/Watt-Hr.) ^⑤	11.4 / 14.0	12.0 / 14.25	12.0 / 14.0
Sound Power Rating [dB(A)] ^⑦	69	74	73
HP Heating Performance			
(High Temp.)BTUH / COP	34600 / 3.5	39500 / 3.6	45000 / 3.5
Power Input (KW)	2.8	3.27	3.77
(Low Temp.) BTUH / COP	20600 / 2.36	23600 / 2.26	26800 / 2.3
Power Input (KW)	2.6	3.06	3.44
HSPF (BTU / Watt-Hr.)	8.0	8.0	8.0
Gas Heating Performance^②			
(High) Input BTUH	75000	96000	96000
Capacity BTUH	60500	77500	77500
Temp. Rise — Min/Max (°F)	30 / 60	30 / 60	30 / 60
(Low) Input BTUH	56250	72000	72000
Capacity BTUH	48400	62000	62000
AFUE	80.0	80	80
Type of Gas ^③	NATURAL	NATURAL/LP	NATURAL
Gas Pipe Size (in.)	1/2	1/2	1/2
POWER CONN.—V/PH/HZ	208-230/3/60	208-230/1/60	208-230/1/60
Min. Brch. Cir. Ampacity ^④	19.8	31.5	33.9
Fuse Size — Max. (amps)	30	50	50
Fuse Size — Recmd. (amps)	30	50	50
COMPRESSOR	SCROLL	SCROLL	SCROLL
Volts/Ph/Hz	208-230/3/60	208-230/1/60	208-230/1/60
R.L. Amps — L.R. Amps	11.5 / 77	18.6 / 105	20.5 / 109
OUTDOOR COIL — TYPE	SPINE-FIN	SPINE-FIN	SPINE-FIN
Rows/F.P.I.	2 / 24	2 / 24	2 / 24
Face Area (sq.ft.)	15.49	18.01	18.01
Tube Size (in.)	3/8	3/8	3/8
Refrigerant Control	EXPANSION VALVE	EXPANSION VALVE	EXPANSION VALVE
INDOOR COIL — TYPE	PLATE FIN	PLATE FIN	PLATE FIN
Rows/F.P.I.	4 / 15	3 / 15	3 / 15
Face Area (sq.ft.)	3.54	5	5.0
Tube Size (in.)	3/8	3/8	3/8
Refrigerant Control	EXPANSION VALVE	EXPANSION VALVE	EXPANSION VALVE
Drain Conn. Size (in.)	3/4 FEMALE NPT	3/4 FEMALE NPT	3/4 FEMALE NPT
OUTDOOR FAN — TYPE	PROPELLER	PROPELLER	PROPELLER
Dia. (in.)	23.4	28.2	28.2
Drive/No. Speeds	DIRECT / 1	DIRECT / 1	DIRECT / 1
CFM @ 0.0 in. w.g. ^⑦	3270	4440	4450
Motor — HP/R.P.M.	1/5 / 830	1/4 / 825	1/4 / 825
Volts/Ph/Hz	208-230/1/60	208-230/1/60	208-230/1/60
F.L. Amps/L.R. Amps	1.1 / 1.9	1.5 / 3.4	1.4 / 3.5
INDOOR FAN — TYPE	CENTRIFUGAL	CENTRIFUGAL	CENTRIFUGAL
Dia x Width (in.)	10 X 10	11 X 10	11 X 10
Drive/No. Speeds	DIRECT / VARIABLE	DIRECT / VARIABLE	DIRECT / VARIABLE
CFM @ 0.0 in. w.g. ^⑤	SEE FAN PERFORMANCE TABLE	SEE FAN PERFORMANCE TABLE	SEE FAN PERFORMANCE TABLE
Motor — HP/R.P.M.	1/2 / VARIABLE	3/4 / VARIABLE	3/4 / VARIABLE
Volts/Ph/Hz	200-230/1/60	208-230/1/60	200-230/1/60
F.L. Amps/L.R. Amps	4.3 / 4.3	6.8 / 6.8	6.8 / 6.8
COMBUSTION FAN — TYPE	CENTRIFUGAL	CENTRIFUGAL	CENTRIFUGAL
Drive/No. Speeds	DIRECT / 2	DIRECT / 2	DIRECT / 2
Motor — HP/R.P.M. (High/Low)	1/45 / 2800/1500	1/45 / 2800/1500	1/45 / 2800/1500
Volts/Ph/Hz	208-230/1/60	208-230/1/60	208-230/1/60
FLA	0.34	0.34	0.34
FILTER / FURNISHED	NO	NO	NO
Type Recommended	THROWAWAY	THROWAWAY	THROWAWAY
Recmd. Face Area (sq. ft.) ^⑥	4	5.3	5.3
REFRIGERANT / Charge (lbs.)	R410A / 7.4	R410A / 7.25	R410A / 7.75
DIMENSIONS	H X W X L	H X W X L	H X W X L
Crated (in.)	47.86 / 44.5 / 52.03	47.86 / 47.4 / 61.75	47.86 / 47.4 / 61.75
WEIGHT / Shipping / Net (lbs.)	488 / 392	653 / 525	653 / 525

① Certified in accordance with the Unitary Air-Conditioner Equipment certification program, which is based on AHRI Standard 210/240.

② All models are U L Listed. Ratings shown are for elevations up to 2000 ft. For higher elevations reduce ratings at a rate of 4% per 1000 ft. elevation.

③ Convertible to LPG.

④ This value is approximate. For more precise value, see Unit Nameplate.

⑤ Based on U.S. Government Standard Tests.

⑥ Filters must be installed in return air stream. Square footages listed are based on 300 f.p.m. face velocity. If permanent filters are used size per manufacturer's recommendation with a clean resistance of 0.05" W.C.

⑦ Sound Power values are not adjusted for AHRI 270-95 tonal corrections.

⑧ Standard Air — Dry Coil — Outdoor.

General Data

MODEL	4DCY4048A3096A	4DCY4060B1120A	4DCY4060A3120A
RATED Volts/PH/Hz	208-230/3/60	208-230/1/60	208-230/3/60
Performance Cooling BTUH^①	47000	58000	57500
Indoor Airflow (CFM)	1470	1745	1745
Power Input (KW)	4.034	4.830	5.478
EER/SEER(BTU/Watt-Hr.) ^⑤	11.75 / 14.0	12.0 / 14.0	11.5 / 14.0
Sound Power Rating [dB(A)] ^⑦	73	76	76
HP Heating Performance			
(High Temp.)BTUH / COP	45500 / 3.5	57500 / 3.55	57000 / 3.5
Power Input (KW)	3.74	4.74	4.43
(Low Temp.) BTUH / COP	26800 / 2.3	36500 / 2.48	36400 / 2.48
Power Input (KW)	3.44	4.30	4.29
HSPF (BTU / Watt-Hr.)	8.0	8.0	8.0
Gas Heating Performance^②			
(High) Input BTUH	96000	120000	120000
Capacity BTUH	77500	96000	96000
Temp. Rise — Min/Max (°F)	30 / 60	30 / 60	30 / 60
(Low) Input BTUH	72000	90000	90000
Capacity BTUH	62000	77500	77500
AFUE	80	80.0	80.0
Type of Gas ^③	NATURAL	NATURAL	NATURAL
Gas Pipe Size (in.)	1/2	1/2	1/2
POWER CONN.—V/PH/HZ	208-230/3/60	208-230/1/60	208-230/3/60
Min. Brch. Cir. Ampacity ^④	26.4	39.9	30.6
Fuse Size — Max. (amps)	40	60	60
Fuse Size — Recmd. (amps)	40	60	60
COMPRESSOR	SCROLL	SCROLL	SCROLL
Volts/Ph/Hz	208-230/3/60	208-230/1/60	208-230/3/60
R.L. Amps — L.R. Amps	14.6 / 91	25 / 134	26.9 / 145
OUTDOOR COIL — TYPE	SPINE-FIN	SPINE-FIN	SPINE-FIN
Rows/F.P.I.	2 / 24	2 / 24	2 / 24
Face Area (sq.ft.)	18.01	23.07	23.57
Tube Size (in.)	3/8	3/8	3/8
Refrigerant Control	EXPANSION VALVE	EXPANSION VALVE	EXPANSION VALVE
INDOOR COIL — TYPE	PLATE FIN	PLATE FIN	PLATE FIN
Rows/F.P.I.	3 / 15	4 / 15	4 / 15
Face Area (sq.ft.)	5.0	5.0	5.0
Tube Size (in.)	3/8	3/8	3/8
Refrigerant Control	EXPANSION VALVE	EXPANSION VALVE	EXPANSION VALVE
Drain Conn. Size (in.)	3/4 FEMALE NPT	3/4 FEMALE NPT	3/4 FEMALE NPT
OUTDOOR FAN — TYPE	PROPELLER	PROPELLER	PROPELLER
Dia. (in.)	28.2	28.2	28.2
Drive/No. Speeds	DIRECT / 1	DIRECT / 1	DIRECT / 1
CFM @ 0.0 in. w.g. ^⑧	4450	5710	5710
Motor — HP/R.P.M.	1/4 / 825	1/3 / 830	1/3 / 830
Volts/Ph/Hz	208-230/1/60	208-230/1/60	208-230/1/60
E.L. Amps/L.R. Amps	1.4 / 3.5	1.7 / 3.5	1.7 / 3.5
INDOOR FAN — TYPE	CENTRIFUGAL	CENTRIFUGAL	CENTRIFUGAL
Dia x Width (in.)	11 X 10	11 X 10	11 X 10
Drive/No. Speeds	DIRECT / VARIABLE	DIRECT / VARIABLE	DIRECT / VARIABLE
CFM @ 0.0 in. w.g. ^⑨	SEE FAN PERFORMANCE TABLE	SEE FAN PERFORMANCE TABLE	SEE FAN PERFORMANCE TABLE
Motor — HP/R.P.M.	3/4 / VARIABLE	1 / VARIABLE	1 / VARIABLE
Volts/Ph/Hz	200-230/1/60	208-230/1/60	208-230/1/60
E.L. Amps/L.R. Amps	6.8 / 6.8	6.9 / 6.9	6.9 / 6.9
COMBUSTION FAN — TYPE	CENTRIFUGAL	CENTRIFUGAL	CENTRIFUGAL
Drive/No. Speeds	DIRECT / 2	DIRECT / 2	DIRECT / 2
Motor — HP/R.P.M. (High/Low)	1/45 / 2800/1500	1/45 / 2800/1500	1/45 / 2800/1500
Volts/Ph/Hz	208-230/1/60	208-230/1/60	208-230/1/60
ELA	0.34	0.34	0.34
FILTER / FURNISHED	NO	NO	NO
Type Recommended	THROWAWAY	THROWAWAY	THROWAWAY
Recmd. Face Area (sq. ft.) ^⑩	5.3	6.7	6.7
REFRIGERANT / Charge (lbs.)	R410A / 7.75	R410A / 11.94	R410A / 10.125
DIMENSIONS	H X W X L	H X W X L	H X W X L
Crated (in.)	47.86 / 47.4 / 61.75	51.86 / 47.4 / 61.75	51.86 / 47.4 / 61.75
WEIGHT / Shipping / Net (lbs.)	653 / 525	676 / 548	676 / 548

① Certified in accordance with the Unitary Air-Conditioner Equipment certification program, which is based on AHRI Standard 210/240.

② All models are U.L. Listed. Ratings shown are for elevations up to 2000 ft. For higher elevations reduce ratings at a rate of 4% per 1000 ft. elevation.

③ Convertible to LPG.

④ This value is approximate. For more precise value, see Unit Nameplate.

⑤ Based on U.S. Government Standard Tests.

⑥ Filters must be installed in return air stream. Square footages listed are based on 300 f.p.m. face velocity. If permanent filters are used size per manufacturer's recommendation with a clean resistance of 0.05" W.C.

⑦ Sound Power values are not adjusted for AHRI 270-95 tonal corrections.

⑧ Standard Air — Dry Coil — Outdoor.

Indoor Blower Performance

Indoor Fan Performance 4DCY4024

Horizontal Airflow

4DCY4024A-HOR	DIPSWITCH SETTINGS				External Static Pressure (in. wg)											
AIRFLOW SETTING	1	2	3	4		0.0	0.1	0.2	0.3	0.4	0.5	0.6	0.7	0.8	0.9	1.0
350 CFM/TON	OFF	OFF	OFF	ON	Watts	52	66	89	115	140	164	186	206	229	259	-
					CFM	706	716	727	733	731	719	700	679	662	659	-
400 CFM/TON*	OFF	OFF	OFF	OFF	Watts	72	94	120	148	177	207	233	254	267	290	-
					CFM	786	793	805	813	813	806	793	780	778	799	-
450 CFM/TON	OFF	OFF	ON	OFF	Watts	80	99	125	153	182	211	243	284	342	-	-
					CFM	860	862	877	892	903	904	897	884	869	-	-

Down Airflow

4DCY4024A-DOWN	DIPSWITCH SETTINGS				External Static Pressure (in. wg)											
AIRFLOW SETTING	1	2	3	4		0.0	0.1	0.2	0.3	0.4	0.5	0.6	0.7	0.8	0.9	1.0
350 CFM/TON	OFF	OFF	OFF	ON	Watts	35	70	90	108	131	160	188	204	225	250	-
					CFM	695	729	734	728	721	715	705	679	680	685	-
400 CFM/TON*	OFF	OFF	OFF	OFF	Watts	79	87	105	129	155	180	206	232	264	306	-
					CFM	846	807	802	810	816	813	803	794	800	846	-
450 CFM/TON	OFF	OFF	ON	OFF	Watts	86	102	127	156	185	213	242	275	319	-	-
					CFM	884	870	882	899	909	907	895	886	898	-	-

Indoor Fan Performance 4DCY4030

Horizontal Airflow

4DCY4030A-HOR	DIPSWITCH SETTINGS				External Static Pressure (in. wg)											
AIRFLOW SETTING	1	2	3	4		0.0	0.1	0.2	0.3	0.4	0.5	0.6	0.7	0.8	0.9	1.0
350 CFM/TON	OFF	OFF	OFF	ON	Watts	-	112	155	176	199	231	270	299	289	197	-
					CFM	-	867	905	904	899	904	914	907	840	650	-
400 CFM/TON*	OFF	OFF	OFF	OFF	Watts	-	157	192	222	249	276	306	343	389	448	-
					CFM	-	997	1011	1012	1009	1006	1006	1006	1001	982	-
450 CFM/TON	OFF	OFF	ON	OFF	Watts	-	213	252	285	317	351	382	401	396	-	-
					CFM	-	1125	1135	1132	1133	1138	1138	1110	1017	-	-

Down Airflow

4DCY4030A-DOWN	DIPSWITCH SETTINGS				External Static Pressure (in. wg)											
AIRFLOW SETTING	1	2	3	4		0.0	0.1	0.2	0.3	0.4	0.5	0.6	0.7	0.8	0.9	1.0
350 CFM/TON	OFF	OFF	OFF	ON	Watts	-	126	152	182	211	237	263	292	333	397	497
					CFM	-	883	900	911	911	901	883	863	849	854	890
400 CFM/TON*	OFF	OFF	OFF	OFF	Watts	-	158	196	224	251	283	318	344	345	295	162
					CFM	-	987	1004	1006	1004	1001	994	977	936	851	697
450 CFM/TON	OFF	OFF	ON	OFF	Watts	-	218	254	288	321	354	390	431	480	-	-
					CFM	-	1118	1128	1132	1131	1127	1127	1142	1183	-	-

*Factory Default Setting

Auxiliary Heating Airflow, horizontal or downflow from .2 to .6" wg.

4DCY4024				
Switch Settings		Selection	Nominal Airflow	
			Low Stage	High Stage
7-OFF	8-OFF	A	600	850
7-ON	8-OFF	B	625	900
7-OFF	8-ON	C	650	925
7-ON	8-ON	D	700	975

4DCY4030				
Switch Settings		Selection	Nominal Airflow	
			Low Stage	High Stage
7-OFF	8-OFF	A	725	1000
7-ON	8-OFF	B	775	1075
7-OFF	8-ON	C	850	1150
7-ON	8-ON	D	925	1250

Indoor Blower Performance

Indoor Fan Performance 4DCY4036

Horizontal Airflow

4DCY4036B-HOR	DIPSWITCH SETTINGS				External Static Pressure (in. wg)											
AIRFLOW SETTING	1	2	3	4		0.0	0.1	0.2	0.3	0.4	0.5	0.6	0.7	0.8	0.9	1.0
350 CFM/TON	OFF	OFF	OFF	ON	Watts	162	173	197	226	256	285	313	343	360	-	-
					CFM	1058	1062	1063	1063	1062	1060	1057	1053	1010	-	-
400 CFM/TON*	OFF	OFF	OFF	OFF	Watts	179	230	265	296	329	366	403	431	436	-	-
					CFM	1179	1196	1204	1206	1205	1203	1199	1194	1185	-	-
450 CFM/TON	OFF	OFF	ON	OFF	Watts	318	336	365	399	435	469	502	533	-	-	-
					CFM	1390	1376	1370	1366	1361	1354	1349	1351	-	-	-

Down Airflow

4DCY4036B-DOWN	DIPSWITCH SETTINGS				External Static Pressure (in. wg)											
AIRFLOW SETTING	1	2	3	4		0.0	0.1	0.2	0.3	0.4	0.5	0.6	0.7	0.8	0.9	1.0
350 CFM/TON	OFF	OFF	OFF	ON	Watts	169	182	210	243	273	301	331	370	433	-	-
					CFM	1025	1062	1068	1063	1060	1061	1064	1055	1015	-	-
400 CFM/TON*	OFF	OFF	OFF	OFF	Watts	225	253	283	315	348	381	414	449	484	-	-
					CFM	1187	1201	1203	1201	1198	1197	1194	1184	1157	-	-
450 CFM/TON	OFF	OFF	ON	OFF	Watts	339	357	390	424	455	483	516	571	-	-	-
					CFM	1391	1377	1377	1375	1366	1352	1344	1360	-	-	-

Indoor Fan Performance 4DCY4042

Horizontal Airflow

4DCY4042A-HOR	DIPSWITCH SETTINGS				External Static Pressure (in. wg)											
AIRFLOW SETTING	1	2	3	4		0.0	0.1	0.2	0.3	0.4	0.5	0.6	0.7	0.8	0.9	1.0
350 CFM/TON	OFF	OFF	OFF	ON	Watts	-	160	185	214	245	277	308	339	368	396	423
					CFM	-	1206	1211	1213	1215	1215	1214	1212	1208	1201	1190
400 CFM/TON*	OFF	OFF	OFF	OFF	Watts	-	231	261	292	325	359	394	431	467	503	536
					CFM	-	1389	1398	1405	1409	1410	1408	1403	1399	1396	1399
450 CFM/TON	OFF	OFF	ON	OFF	Watts	-	326	362	393	421	450	482	517	556	597	-
					CFM	-	1582	1592	1593	1587	1577	1566	1557	1553	1556	-

Down Airflow

4DCY4042A-DOWN	DIPSWITCH SETTINGS				External Static Pressure (in. wg)											
AIRFLOW SETTING	1	2	3	4		0.0	0.1	0.2	0.3	0.4	0.5	0.6	0.7	0.8	0.9	1.0
350 CFM/TON	OFF	OFF	OFF	ON	Watts	-	176	203	232	262	294	325	357	388	417	443
					CFM	-	1207	1214	1217	1216	1213	1208	1201	1193	1185	1177
400 CFM/TON*	OFF	OFF	OFF	OFF	Watts	-	253	290	323	355	386	420	455	491	526	558
					CFM	-	1405	1411	1413	1412	1407	1399	1389	1377	1366	1357
450 CFM/TON	OFF	OFF	ON	OFF	Watts	-	367	379	409	446	485	522	556	591	633	-
					CFM	-	1599	1577	1570	1569	1566	1560	1550	1537	1528	-

*Factory Default Setting

Auxiliary Heating Airflow, horizontal or downflow from .2 to .6" wg.

4DCY4036				
Switch Settings		Selection	Nominal Airflow	
			Low Stage	High Stage
7-OFF	8-OFF	A	725	1000
7-ON	8-OFF	B	775	1075
7-OFF	8-ON	C	850	1150
7-ON	8-ON	D	925	1250

4DCY4042				
Switch Settings		Selection	Nominal Airflow	
			Low Stage	High Stage
7-OFF	8-OFF	A	1075	1375
7-ON	8-OFF	B	1100	1450
7-OFF	8-ON	C	1150	1500
7-ON	8-ON	D	1200	1575

Indoor Blower Performance

Indoor Fan Performance 4DCY4048

Horizontal Airflow

4DCY4048-HOR	DIPSWITCH SETTINGS				External Static Pressure (in. wg)											
AIRFLOW SETTING	1	2	3	4		0.0	0.1	0.2	0.3	0.4	0.5	0.6	0.7	0.8	0.9	1.0
350 CFM/TON	OFF	OFF	OFF	ON	Watts	187	232	264	291	318	347	379	413	446	472	-
					CFM	1355	1387	1396	1392	1382	1370	1360	1351	1341	1326	-
400 CFM/TON*	OFF	OFF	OFF	OFF	Watts	315	324	352	389	428	464	498	529	563	606	-
					CFM	1603	1581	1577	1580	1583	1583	1577	1567	1558	1556	-
450 CFM/TON	OFF	OFF	ON	OFF	Watts	301	431	507	552	584	615	651	694	739	779	-
					CFM	1752	1794	1812	1816	1812	1806	1800	1797	1793	1785	-

Down Airflow

4DCY4048-DOWN	DIPSWITCH SETTINGS				External Static Pressure (in. wg)											
AIRFLOW SETTING	1	2	3	4		0.0	0.1	0.2	0.3	0.4	0.5	0.6	0.7	0.8	0.9	1.0
350 CFM/TON	OFF	OFF	OFF	ON	Watts	208	254	284	312	343	379	414	437	460	490	-
					CFM	1337	1393	1398	1388	1383	1390	1399	1384	1380	1370	-
400 CFM/TON*	OFF	OFF	OFF	OFF	Watts	302	349	386	423	465	509	552	583	599	628	-
					CFM	1574	1580	1585	1589	1594	1598	1601	1597	1584	1556	-
450 CFM/TON	OFF	OFF	ON	OFF	Watts	501	523	555	592	631	672	714	760	800	845	-
					CFM	1847	1823	1817	1818	1820	1819	1817	1820	1815	1810	-

Indoor Fan Performance 4DCY4060

Horizontal Airflow

4DCY4060-HOR	DIPSWITCH SETTINGS				External Static Pressure (in. wg)											
AIRFLOW SETTING	1	2	3	4		0.0	0.1	0.2	0.3	0.4	0.5	0.6	0.7	0.8	0.9	1.0
350 CFM/TON	OFF	OFF	OFF	ON	Watts	394	427	464	504	548	591	633	668	-	-	-
					CFM	1673	1772	1799	1793	1779	1771	1767	1756	-	-	-
400 CFM/TON*	OFF	OFF	OFF	OFF	Watts	695	642	660	710	764	811	849	893	966	1108	-
					CFM	2054	2036	2031	2032	2033	2031	2023	2012	2002	2000	-

Down Airflow

4DCY4060-DOWN	DIPSWITCH SETTINGS				External Static Pressure (in. wg)											
AIRFLOW SETTING	1	2	3	4		0.0	0.1	0.2	0.3	0.4	0.5	0.6	0.7	0.8	0.9	1.0
350 CFM/TON	OFF	OFF	OFF	ON	Watts	443	461	493	532	571	607	642	680	-	-	-
					CFM	1796	1741	1726	1725	1722	1712	1698	1692	-	-	-
400 CFM/TON*	OFF	OFF	OFF	OFF	Watts	740	697	715	763	819	866	892	894	872	835	-
					CFM	2012	1987	1979	1977	1976	1969	1950	1913	1852	1759	-

*Factory Default Setting

Auxiliary Heating Airflow, horizontal or downflow from .2 to .6" wg.

4DCY4048 *096				
Switch Settings		Selection	Nominal Airflow	
			Low Stage	High Stage
7-OFF	8-OFF	A	1075	1375
7-ON	8-OFF	B	1100	1450
7-OFF	8-ON	C	1150	1500
7-ON	8-ON	D	1200	1575

* can be 1 or 3

4DCY4060 *120				
Switch Settings		Selection	Nominal Airflow	
			Low Stage	High Stage
7-OFF	8-OFF	A	1375	1800
7-ON	8-OFF	B	1450	1900
7-OFF	8-ON	C	1525	1975
7-ON	8-ON	D	1575	2075

* can be 1 or 3

Typical Field Wiring

4DCY FIELD WIRING DIAGRAM

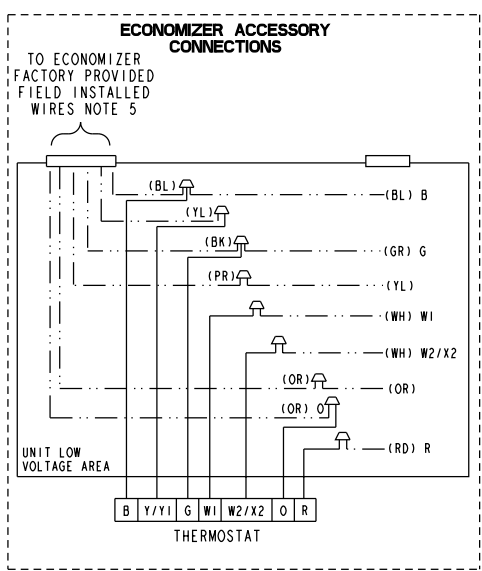
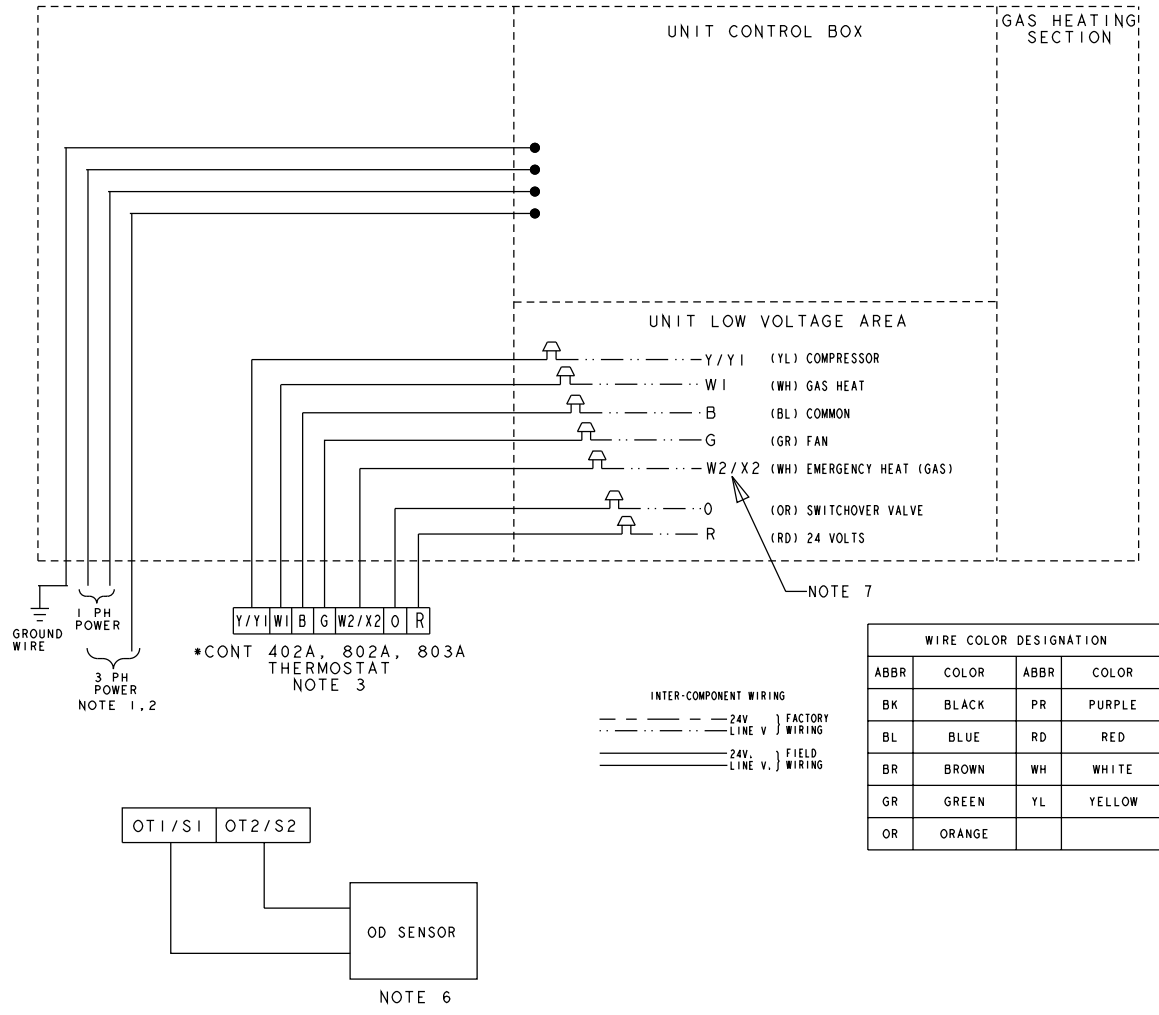

- NOTES:
1. FUSED DISCONNECT SIZE, POWER WIRING AND GROUNDING OF EQUIPMENT MUST COMPLY WITH CODES.
 2. BE SURE POWER SUPPLY AGREES WITH EQUIPMENT NAMEPLATE.
 3. LOW VOLTAGE WIRING TO BE 18 AWG MINIMUM CONDUCTOR.
 4. SEE UNIT DIAGRAM FOR ELECTRICAL CONNECTION DETAILS.
 5. WHEN THE BAYECON101A, 102A, 200A OR 201A ECONOMIZER IS INSTALLED, THE BAYRLAY004 RELAY ACCESSORY KIT IS REQUIRED TO INTERFACE THE ECONOMIZER TO THE HEAT PUMP FOR PROPER SYSTEM OPERATION.
 6. THE OUTDOOR SENSOR SHOULD BE LOCATED IN AN AREA WHICH WILL PROVIDE A REPRESENTATIVE OUTDOOR TEMPERATURE.
 7. A FIELD INSTALLED JUMPER WIRE MUST BE PLACED BETWEEN W1 AND W2/X2 AT THE UNIT FOR COMFORT CONTROLS *CONT 802A AND 803A TO PROPERLY FUNCTION.

Typical Wiring

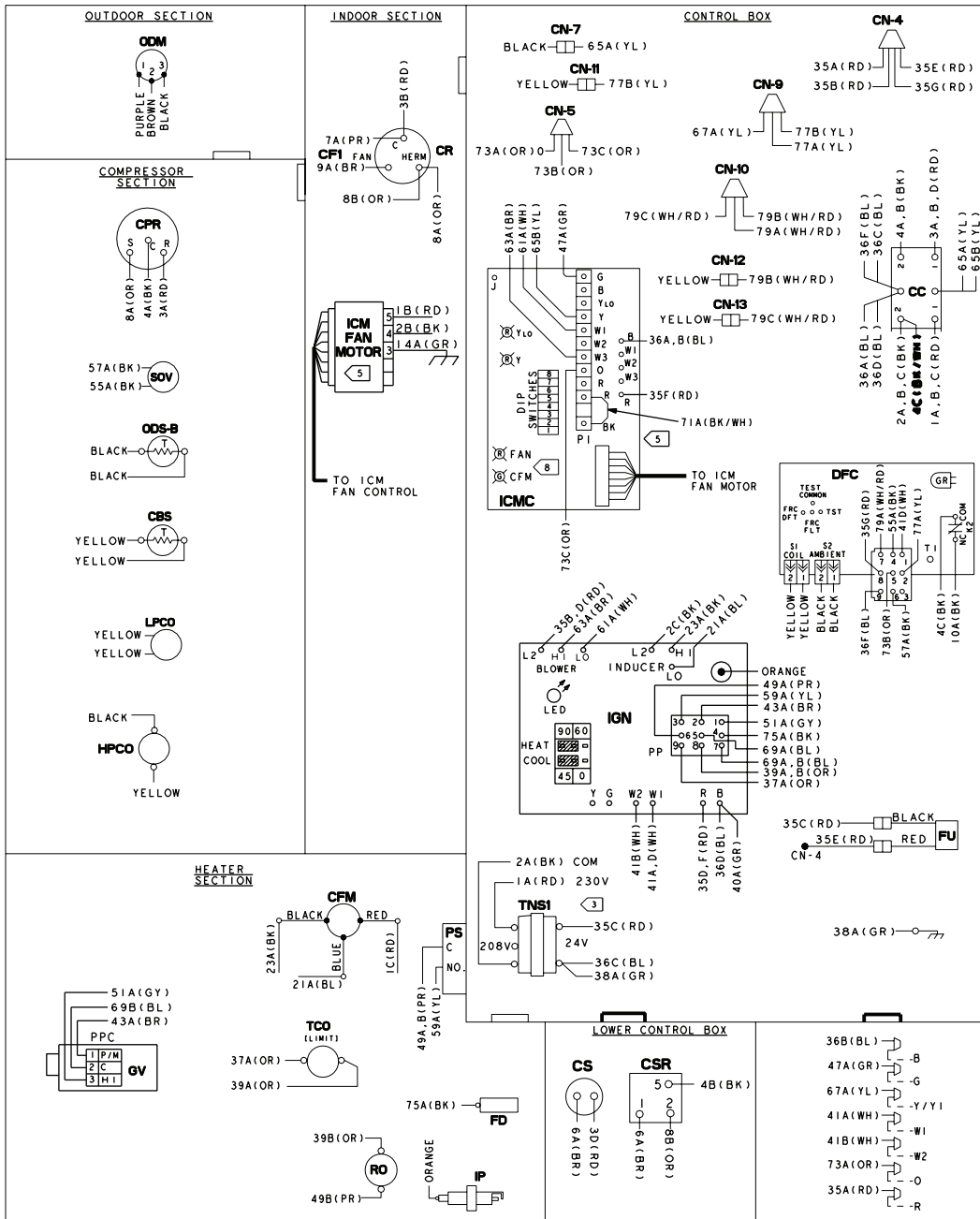

- NOTES:**
- CONNECTIONS SHOWN ARE FOR A TYPICAL THERMOSTAT. SEE SCHEMATIC SUPPLIED WITH THERMOSTAT FOR PROPER CONNECTIONS. LOW VOLTAGE WIRING TO UNIT MAY BE NEC CLASS 2 AND MUST BE A MIN. OF 18 A.W.G. SET THERMOSTAT HEAT ANTICIPATOR TO .3 AMPS.
 - MAXIMUM ADDITIONAL EXTERNAL LOAD (PILOT DUTY) BETWEEN "B" AND "R" OF 0.5 AMPS. 24 VAC IS AVAILABLE IN THE COOLING MODE ONLY.
 - FOR 208 VOLT OPERATION MAKE THE FOLLOWING WIRING CHANGES:
A: AT TNS1 REMOVE 1A(RD) WIRE AND CONNECT TO 208V TERMINAL ON TRANSFORMER.
 - IF ANY OF THE ORIGINAL WIRE AS SUPPLIED IN THIS UNIT MUST BE REPLACED, REPLACE IT WITH APPLIANCE WIRING MAT'L RATED AT 105° C.
 - IF OPTIONAL HUMIDISTAT ACCESSORY IS USED, ON THE ICMC BOARD CUT THE 71A(BK/WH) JUMPER AND CONNECT THE HUMIDISTAT BETWEEN TERMINALS.

WIRE COLOR DESIGNATION			
ABB#	COLOR	ABB#	COLOR
BK	BLACK	PR	PURPLE
BL	BLUE	RD	RED
BR	BROWN	WH	WHITE
GR	GREEN	YL	YELLOW
OR	ORANGE		

DEVICE	DESCRIPTION	LINE
CBS	COIL BOTTOM SENSOR	35
CC	COMPRESSOR CONTACTOR COIL	68
CF1	OUTDOOR FAN CAPACITOR	19
CFM	COMBUSTION FAN MOTOR	24
CN	CONNECTOR OR WIRE NUT	
CPR	COMPRESSOR	14
CR	COMPRESSOR RUN CAPACITOR	14
CS	COMPRESSOR START CAPACITOR	9
CSR	COMPRESSOR START RELAY COIL	9
DFC	DEFROST CONTROL	31-39
FD	FLAME DETECTOR	52
FU	FUSE	29
GV	GAS VALVE	45
HPCO	HIGH PRESSURE SWITCH	68
ICM	INTEGRATED COMMUTATED MOTOR	22
ICMC	INTEGRATED COMMUTATED MOTOR CONTROL	56-64
IGN	IGNITION CONTROL MODULE	23, 53
IOL	INTERNAL OVERLOAD	14
IP	IGNITION PROBE	53
LED	IGN DIAGNOSTICS INDICATOR	47
LPCO	LOW PRESSURE SWITCH	68
ODM	OUTDOOR FAN MOTOR	18
ODS	OUTDOOR AMBIENT SENSOR	37
PP	POLARIZED PLUG	48
PS	PRESSURE SWITCH	48
RO	ROLLOUT LIMIT	40
SOV	SWITCHOVER VALVE	48
TCO	TEMPERATURE LIMIT SWITCH	48
TNS1	CONTROL POWER TRANSFORMER	28

MODELS
4DCY4024A1
4DCY4030A1

ICMC DIP SWITCH SETTINGS					
DIP SWITCH SETTINGS		COOLING/HEAT PUMP CFM	4DCY4024	4DCY4030	NOMINAL AIRFLOW
SW 1	SW 2	SW 3	SW 4		
OFF	OFF	OFF	ON	350 CFM/TON	350 CFM/TON
OFF	OFF	OFF	OFF	400 CFM/TON	400 CFM/TON
OFF	OFF	ON	OFF	450 CFM/TON	450 CFM/TON
ON	ON	OFF	OFF	RATED CFM/TON	RATED CFM/TON
SW 5 SW 6		FAN OFF-DELAY OPTIONS		FAN OFF-DELAY OPTIONS	
ON	OFF	NONE		NONE	
ON	ON	45 SECONDS		45 SECONDS	
OFF	ON	90 SECONDS		90 SECONDS	
ON	ON	ENHANCED		ENHANCED	
SW 7 SW 8		HEATING AIRFLOW		HEATING AIRFLOW	
OFF	OFF	850 CFM		1100 CFM	
ON	OFF	900 CFM		1175 CFM	
OFF	ON	925 CFM		1275 CFM	
ON	ON	975 CFM		1375 CFM	

** FACTORY SETTING.
AT CONTINUOUS FAN SETTING ("G" ONLY) AIRFLOW VALUES ARE APPROXIMATELY 50% OF LISTED VALUE.
THE HEAT PUMP FAN OFF-DELAY IS THE SAME AS THE COOLING MODE.

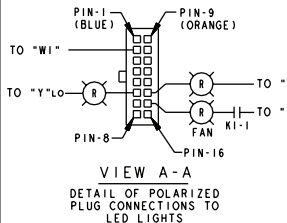

Typical Wiring

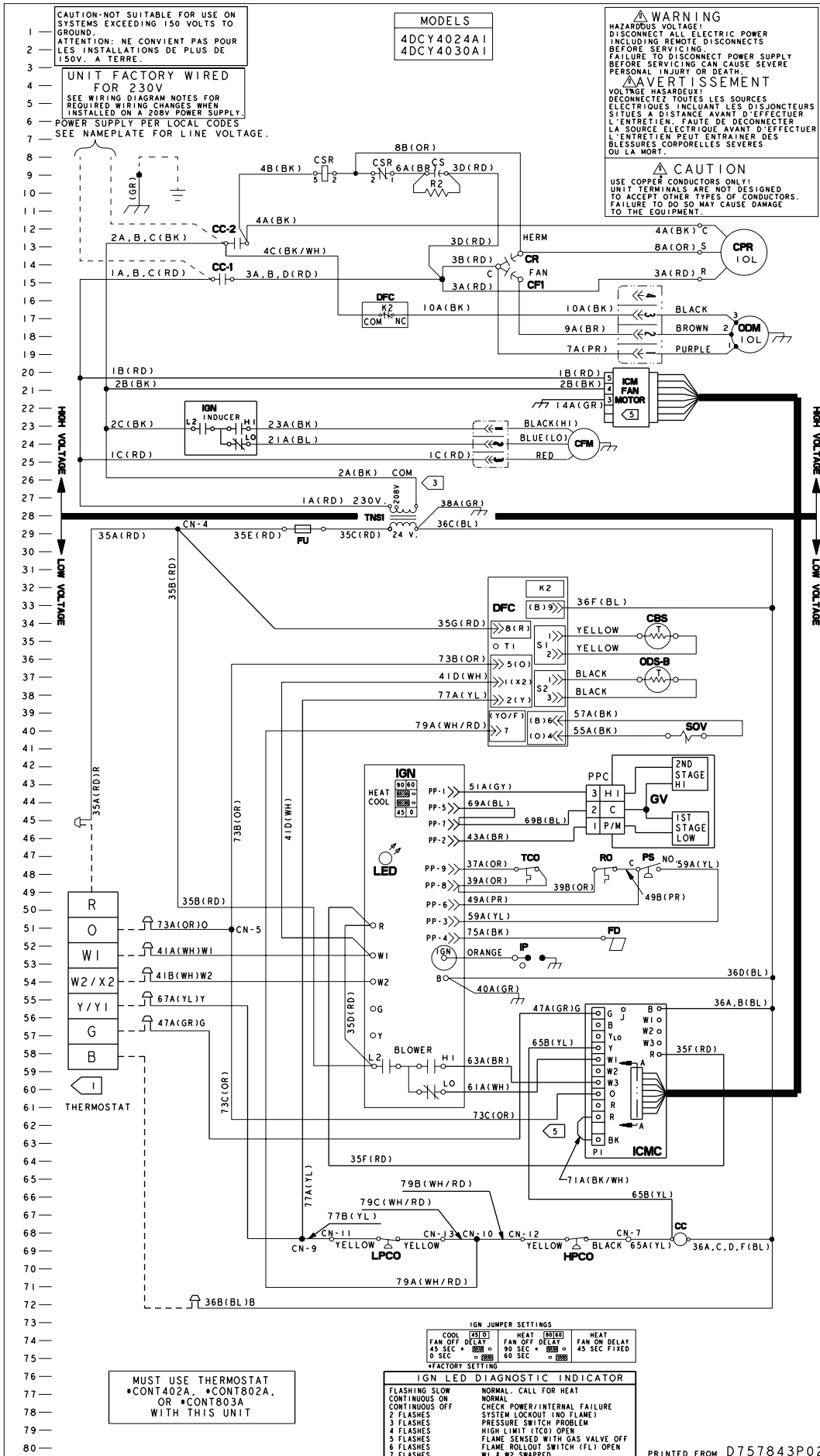

Optional Equipment

BAYCURB050A Full Perimeter Roof Mounting Curb for *****024-036

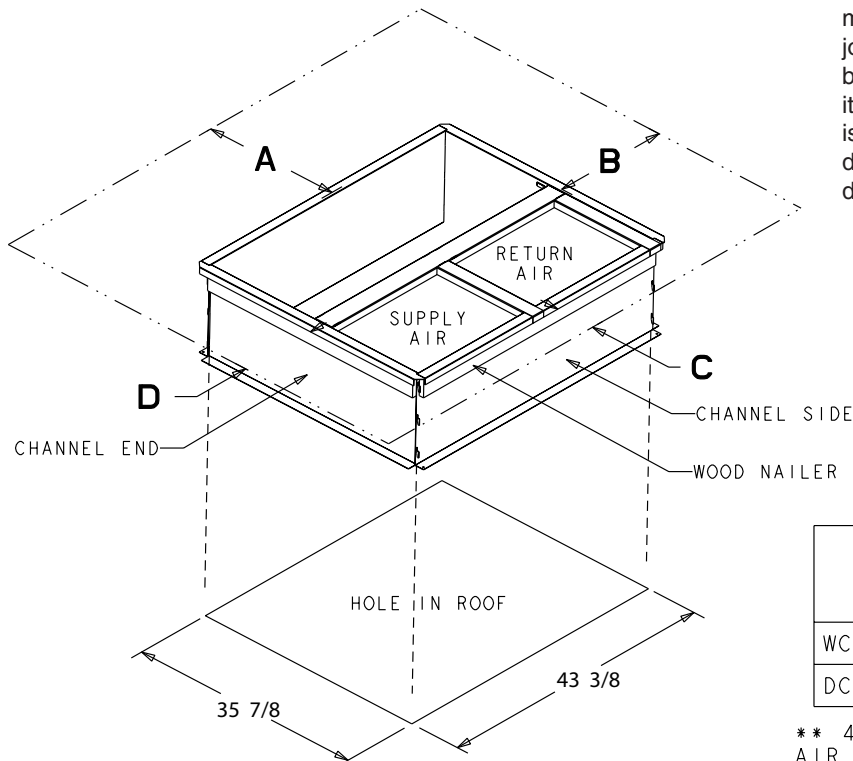
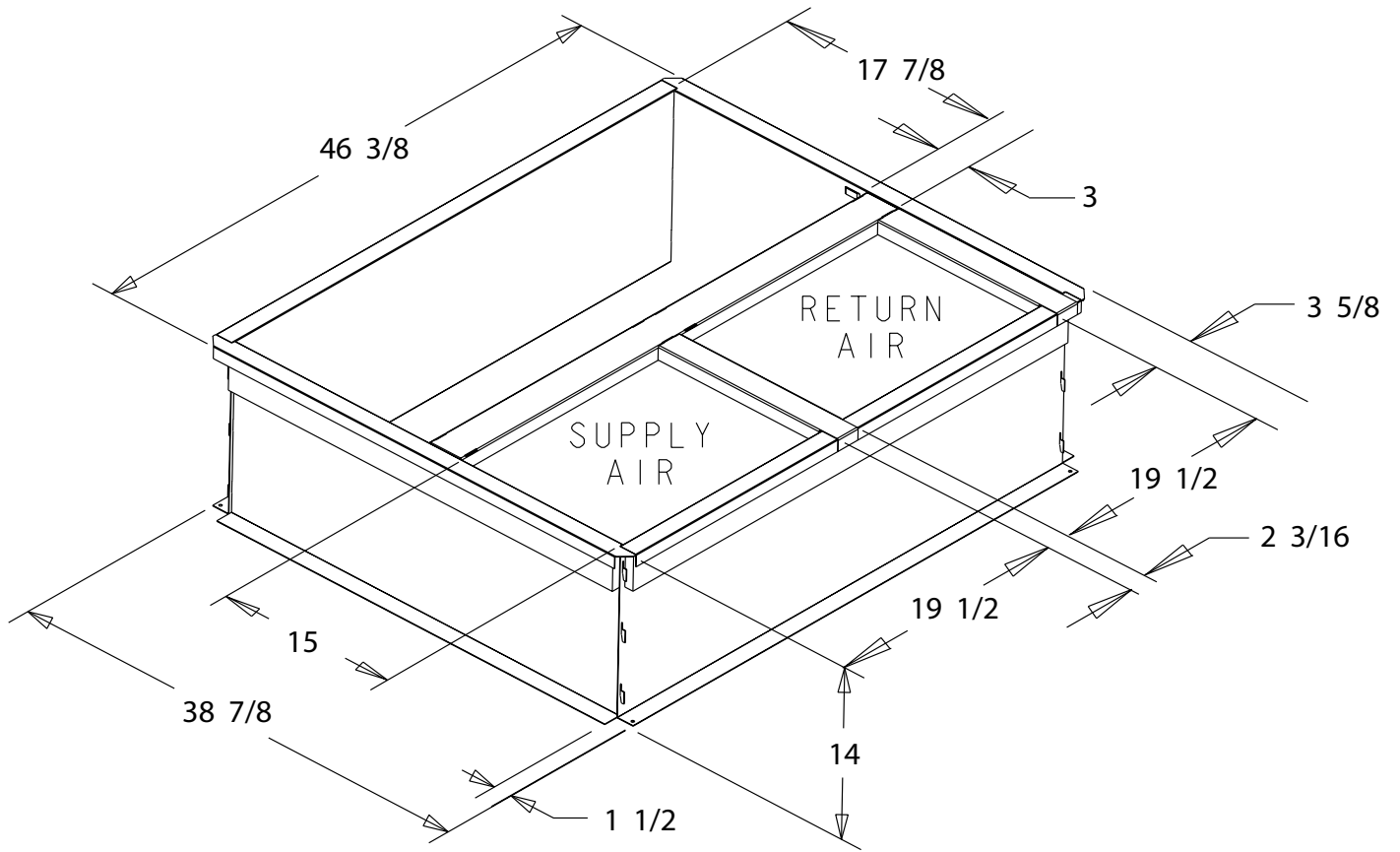

The drawings on this page are prepared by the manufacturer in order to provide detail regarding job layout only. These drawings are not intended to be used as a basis to construct, build or modify the items depicted in the drawings. The manufacturer is not responsible for the unauthorized use of these drawings and expressly disclaims any liability for damages resulting from such unauthorized use.

	SERVICE CLEARANCE DIMENSIONS			
	A	B	C	D
WC*/TC*	42.00	36.00	12.00**	24.00
DC*/YC*	42.00	36.00	12.00**	36.00

** 42.00 WITH ECONOMIZER WITH 25% FRESH AIR ACCESSORY

Optional Equipment

BAYCURB051A Full Perimeter Roof Mounting Curb for *****042-060

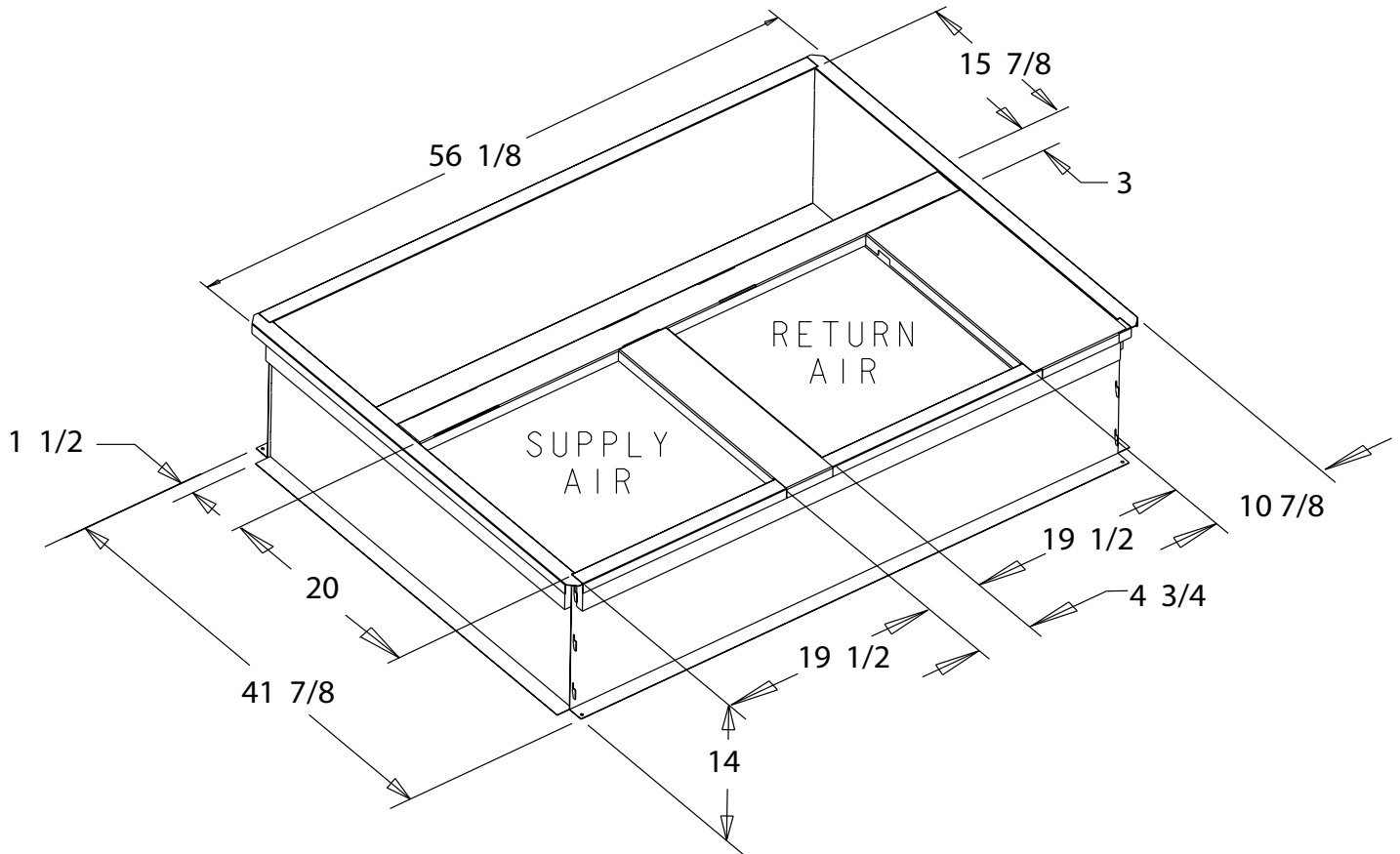

The drawings on this page are prepared by the manufacturer in order to provide detail regarding job layout only. These drawings are not intended to be used as a basis to construct, build or modify the items depicted in the drawings. The manufacturer is not responsible for the unauthorized use of these drawings and expressly disclaims any liability for damages resulting from such unauthorized use.

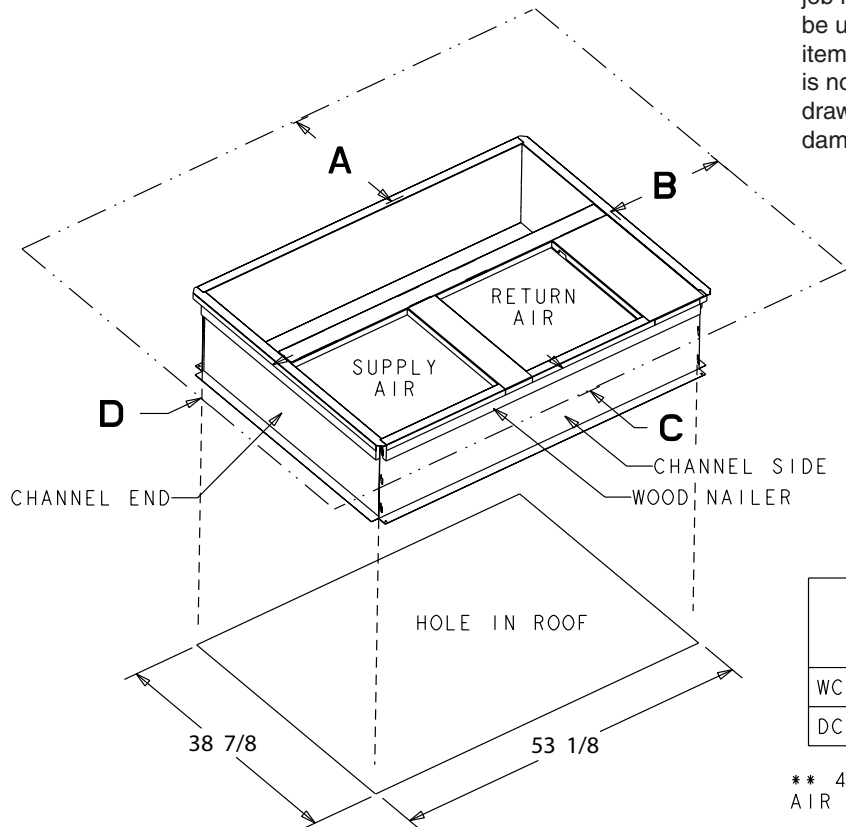

	SERVICE CLEARANCE DIMENSIONS			
	A	B	C	D
WC*/TC*	42.00	36.00	12.00**	24.00
DC*/YC*	42.00	36.00	12.00**	36.00

** 42.00 WITH ECONOMIZER WITH 25% FRESH AIR ACCESSORY

Optional Equipment

BAYFLTR101, 201B, 1" - 2" Filter Rack (Mounts in Filter/Coil Section)

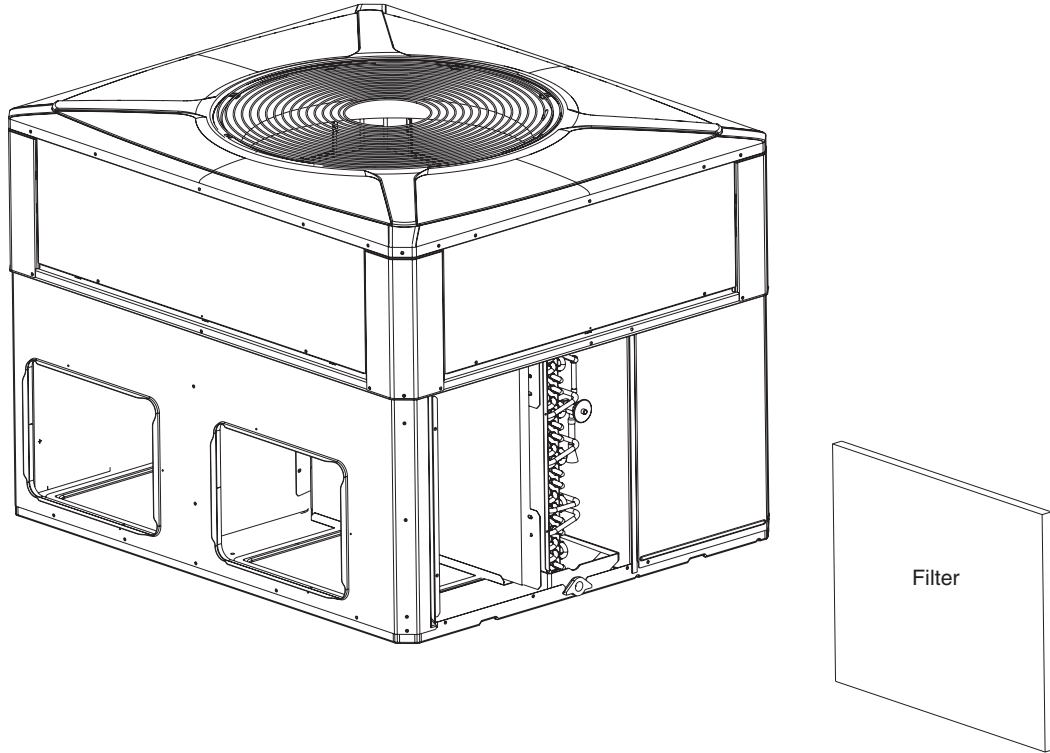

BAYACCDOR1A & BAYACCDOR2A Hinged Filter Access Door Replaces Filter/Coil Access Panel

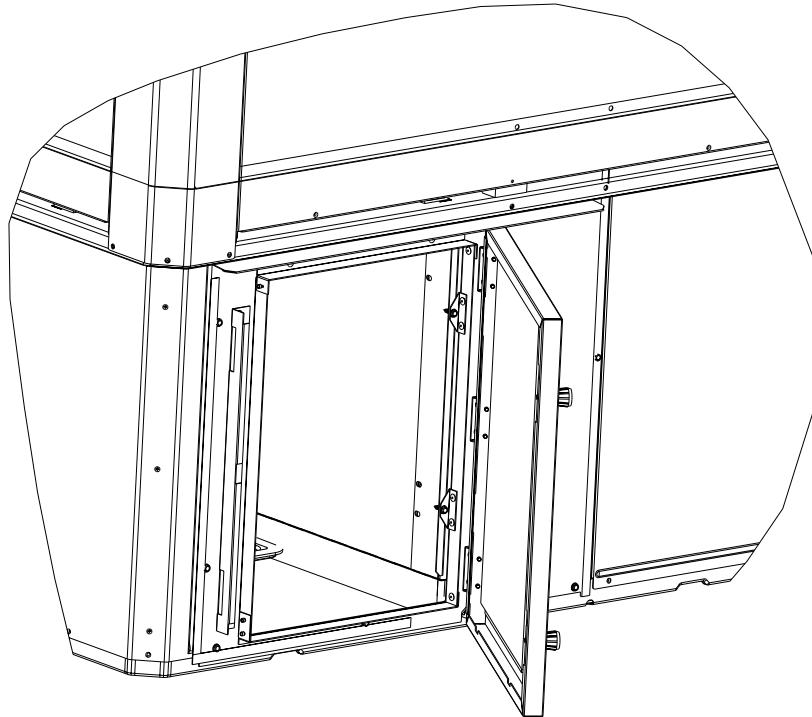

The drawings on this page are prepared by the manufacturer in order to provide detail regarding job layout only. These drawings are not intended to be used as a basis to construct, build or modify the items depicted in the drawings. The manufacturer is not responsible for the unauthorized use of these drawings and expressly disclaims any liability for damages resulting from such unauthorized use.

Optional Equipment

BAYECON101,102A Down Discharge Economizer and Rain Hood (Mounts Over Horizontal Return Air Opening)

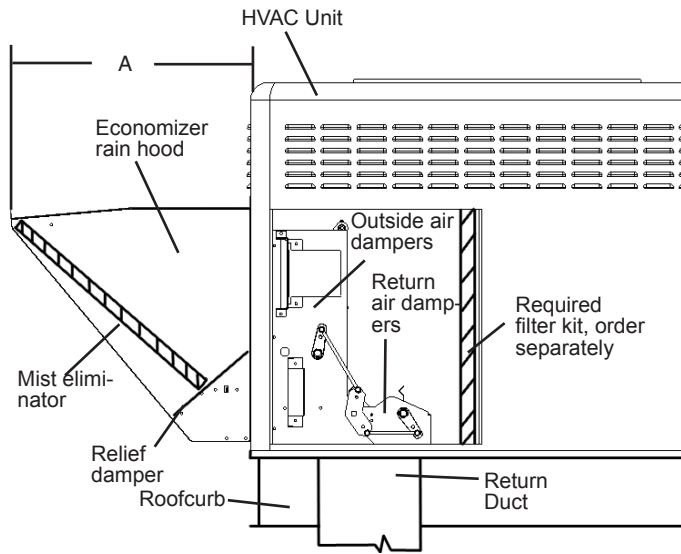

Economizer	Unit Application Models	A
BAYECON101A	4TC*,WC*,YC*,DC* *018-036	20.125"
BAYECON102A	4TC*,WC*,YC*,DC* *042-060	24.375"

BAYECON200,201A Horizontal Economizer and Rain Hood

The drawings on this page are prepared by the manufacturer in order to provide detail regarding job layout only. These drawings are not intended to be used as a basis to construct, build or modify the items depicted in the drawings. The manufacturer is not responsible for the unauthorized use of these drawings and expressly disclaims any liability for damages resulting from such unauthorized use.

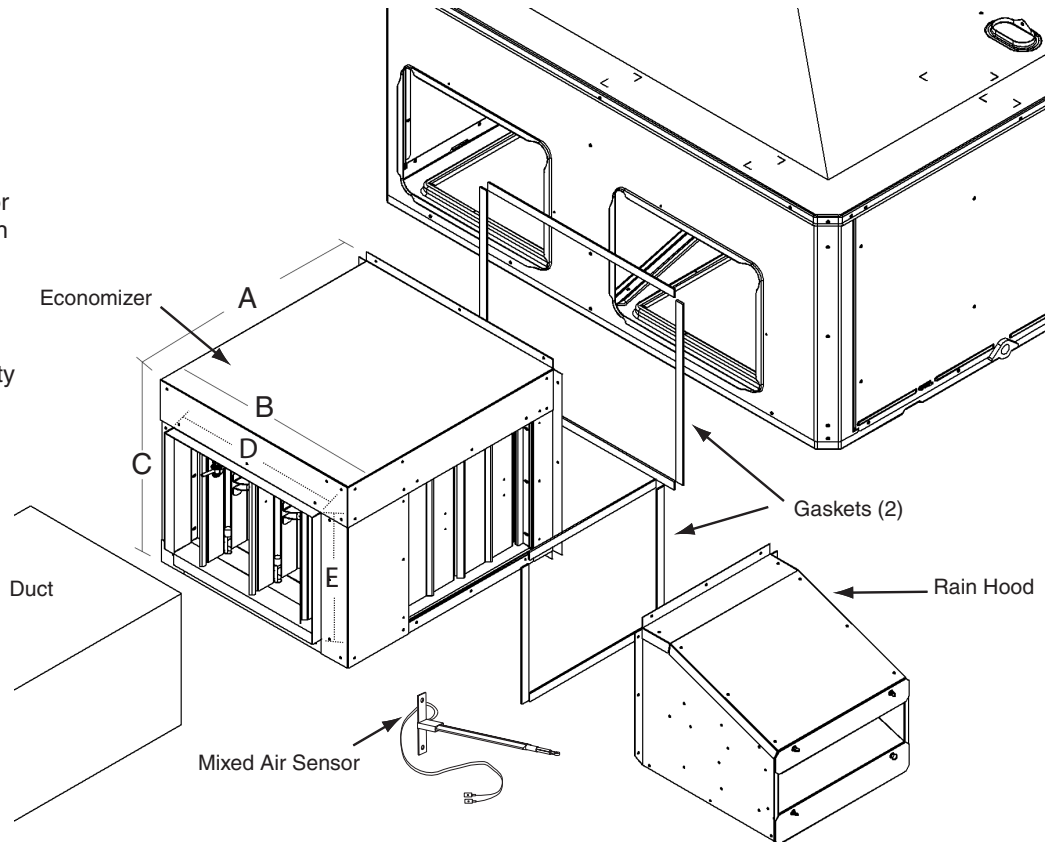

Economizer	A	B	C	D	E	F
BAYECON200AA	22"	20"	16 7/8"	15 11/16"	11 11/16"	15"
BAYECON201AA	26"	22 21/32"	19"	17 11/16"	14 11/16"	21-3/8"

Optional Equipment

BAYOSAH001, 002A, 25% Outside Air Damper (Replaces Filter/Coil Access Panel)

The drawings on this page are prepared by the manufacturer in order to provide detail regarding job layout only. These drawings are not intended to be used as a basis to construct, build or modify the items depicted in the drawings. The manufacturer is not responsible for the unauthorized use of these drawings and expressly disclaims any liability for damages resulting from such unauthorized use.

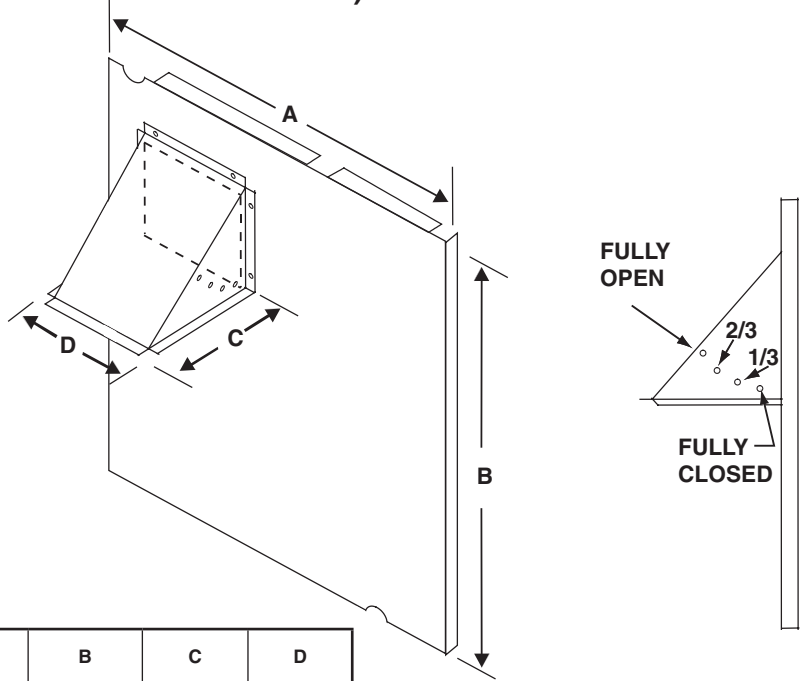

Manual Fresh Air Model	Unit Application Models	A	B	C	D
BAYOSAH001	4YC,WC3018-036 4TC*3018-036 4W/T/Y/DCY4024-036 4W/Y/DCZ6036	22 7/16"	20 11/16"	12 3/8"	9 3/16"
BAYOSAH002	4YC,WC3042-060 4TC*3042-060 4W/T/Y/DCY4042-060 4W/Y/DCZ6048-060	25 3/16"	20 11/16"	12 3/8"	9 3/16"

BAYDMPR101,102A, 25% Motorized Outside Air Damper (Mounts Over Horizontal Return Air Opening)

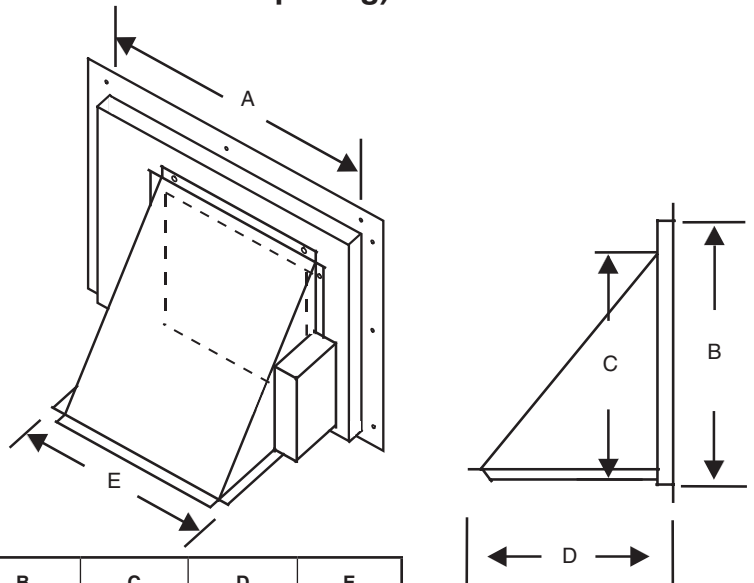

	Unit Application Models	A	B	C	D	E
BAYDMPR101A	4YC,WC3018-036 4TC3018-036 4W/T/Y/DCY4024-036 4W/Y/DCZ6036	15 13/16"	11 13/16"	10 1/4"	11 1/2"	12 1/4"
BAYDMPR102A	4YC,WC3042-060 4TC3042-060 4W/T/Y/DCY4042-060 4W/Y/DCZ6048-060	18 3/16"	15 1/8"	10 1/4"	11 1/2"	12 1/4"

Dimensional Data

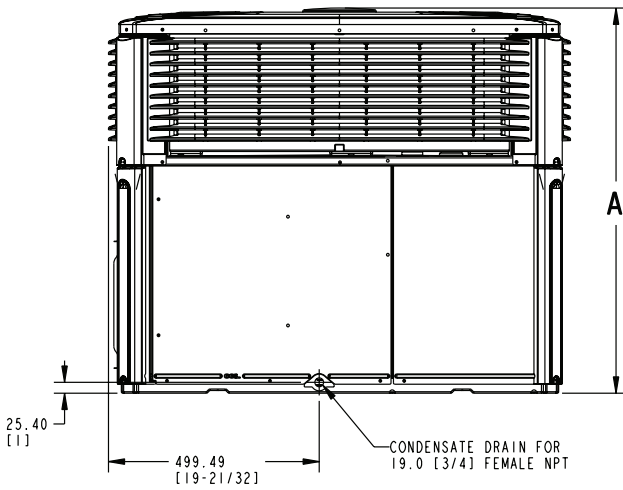
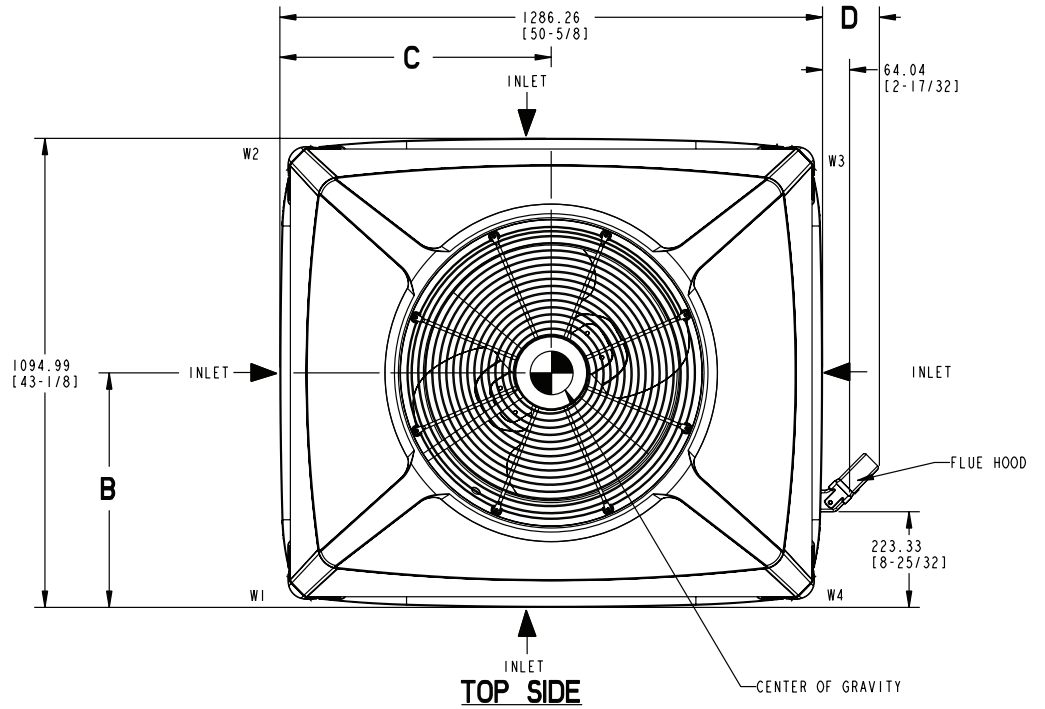

LEFT SIDE

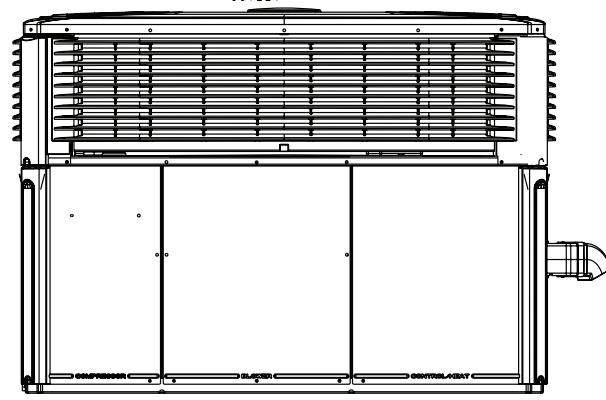

FRONT SIDE

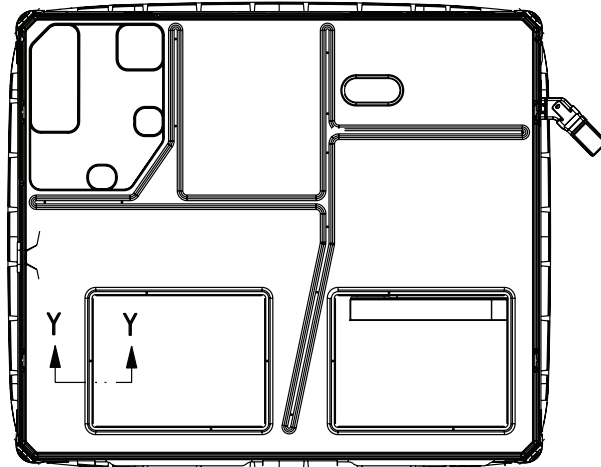
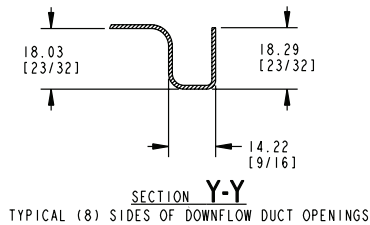

BOTTOM SIDE

4DCY4024 through 4DCY4036 (1 of 3)

Dimensional Data

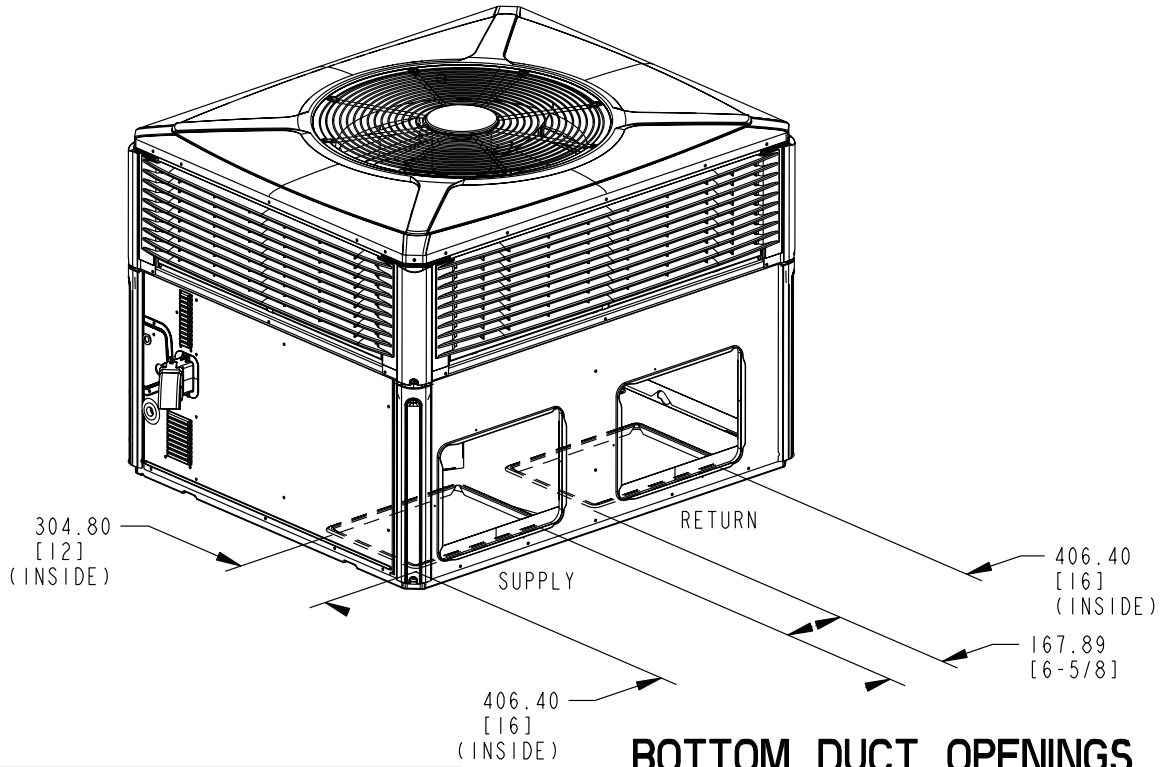

BOTTOM DUCT OPENINGS

RECOMMENDED SERVICE CLEARANCE MM/IN.		
		WITH ECONOMIZER
BACK SIDE	304.8 [12]	762.0 [30]
LEFT SIDE	762.0 [30]	914.4 [36]
RIGHT SIDE	914.4 [36]	-
FRONT SIDE	1066.8 [42]	-

CLEARANCE TO COMBUSTIBLE MATERIAL MM/IN.	
BOTTOM	0
BACK SIDE	25.4 [1]
LEFT SIDE	152.4 [6]
RIGHT SIDE	304.8 [12]
FRONT SIDE	304.8 [12]
TOP	914.4 [36]

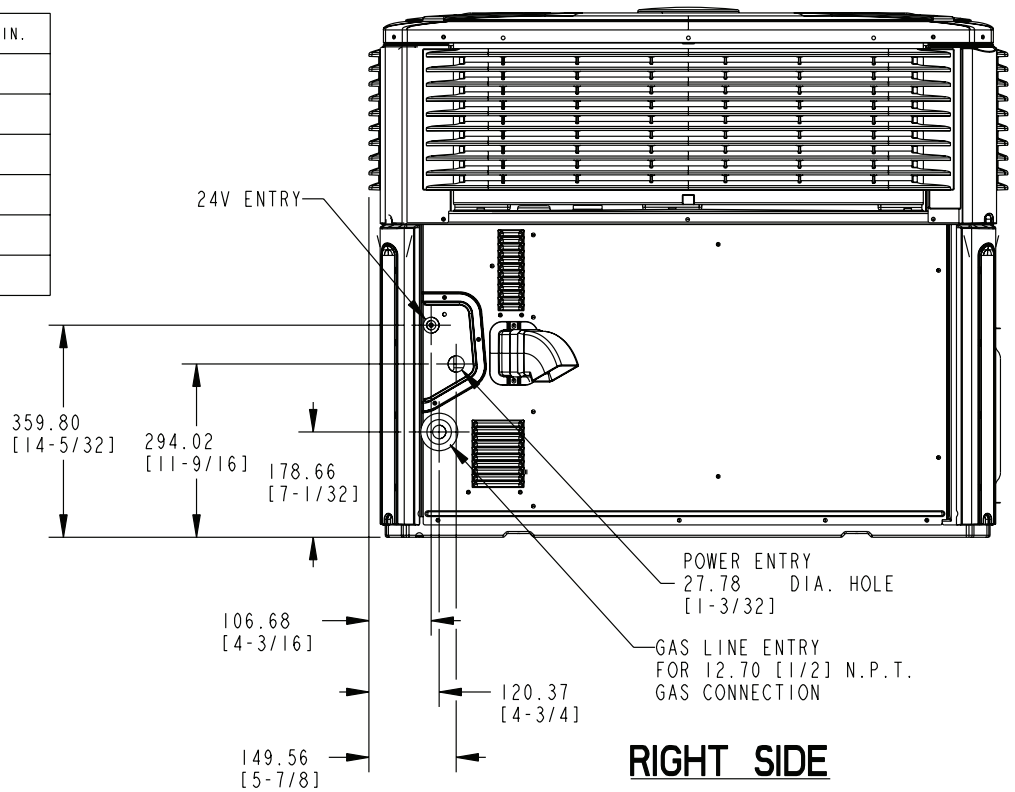

4DCY4024 through 4DCY4036 (2 of 3)

Dimensional Data

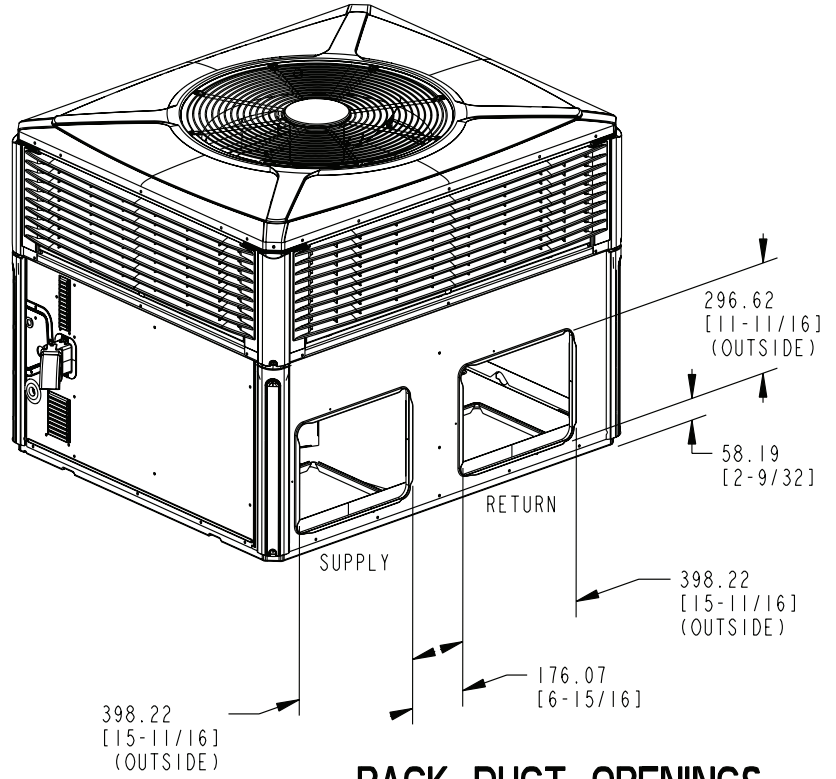

BACK DUCT OPENINGS

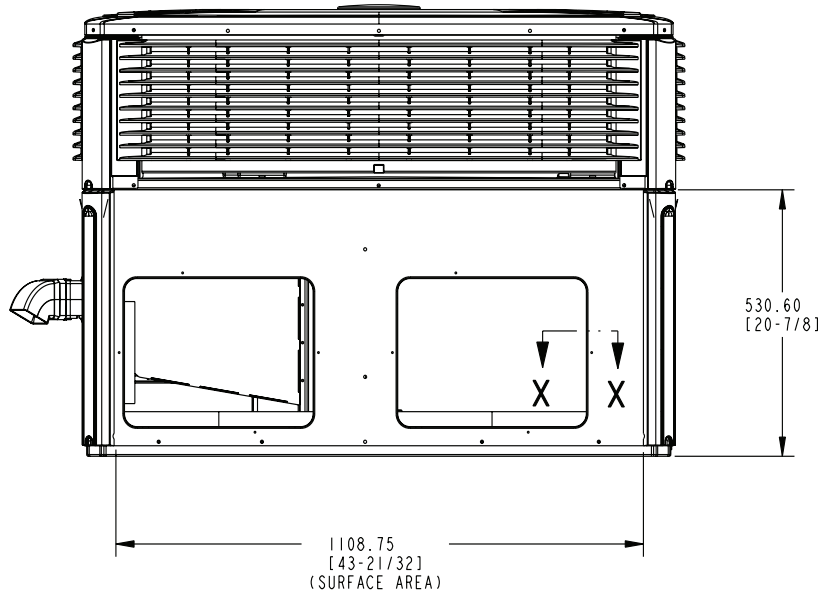

BACK SIDE

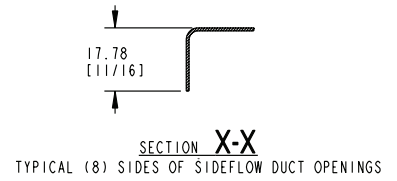

MODEL	HEIGHT MM/IN.	FLUE HOOD W/BRKT MM/IN.	APPROX. CORNER WEIGHT - KG/LBS				SHIPPING WEIGHT KG/LBS	TOTAL UNIT WEIGHT KG/LBS	CENTER OF GRAVITY MM/IN.	
	A		D	W1	W2	W3			W4	B
4CY4024 (064)	903.29 [35-9/16]	-	59.0 [130]	37.2 [82]	31.3 [69]	48.5 [107]	218.4 (481)	174.8 [385]	401.3 [15.8]	546.1 [21.5]
4CY4030 (075)										
4CY4036/4YC6036 (075)	949.99 [37-3/8]	117.86 [4-5/8]	60.3 [133]	36.3 [80]	30.4 [67]	50.3 [111]	221.6 (488)	178.0 [392]	388.6 [15.3]	558.8 [22.0]
4CY4036/4YC6036 (096)			61.2 [135]	36.7 [81]	30.8 [68]	51.3 [113]	223.8 (493)	180.1 [397]	388.6 [15.3]	558.8 [22.0]
4DCY4024 (064)	903.29 [35-9/16]	-	60.8 [134]	38.1 [84]	31.3 [69]	48.5 [107]	218.4 (481)	174.8 [385]	398.8 [15.7]	546.1 [21.5]
4DCY4030 (075)										
4DCY4036/4DCZ6036 (075)	949.99 [37-3/8]	117.86 [4-5/8]	62.1 [137]	37.2 [82]	30.4 [67]	50.3 [111]	221.6 (488)	178.0 [392]	386.1 [15.2]	558.8 [22.0]

4DCY4024 through 4DCY4036 (3 of 3)

Dimensional Data

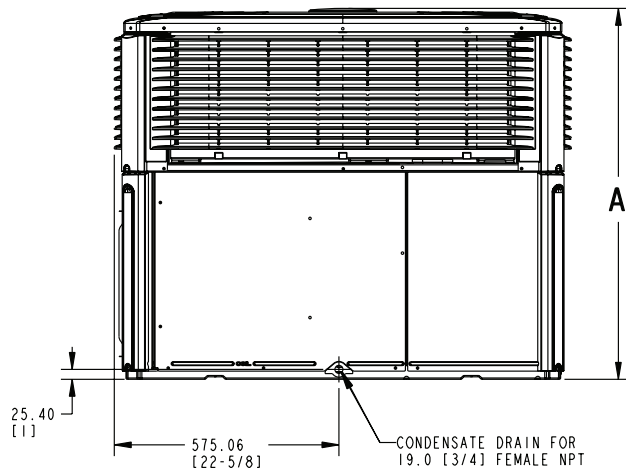
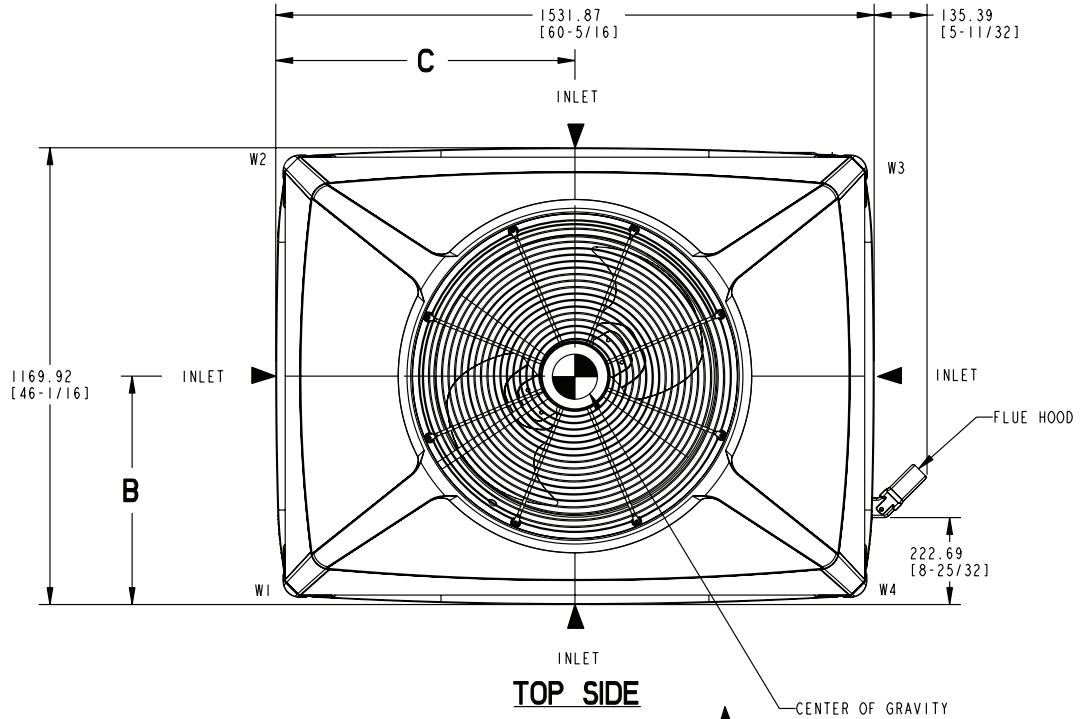

LEFT SIDE

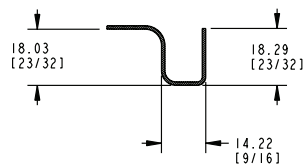
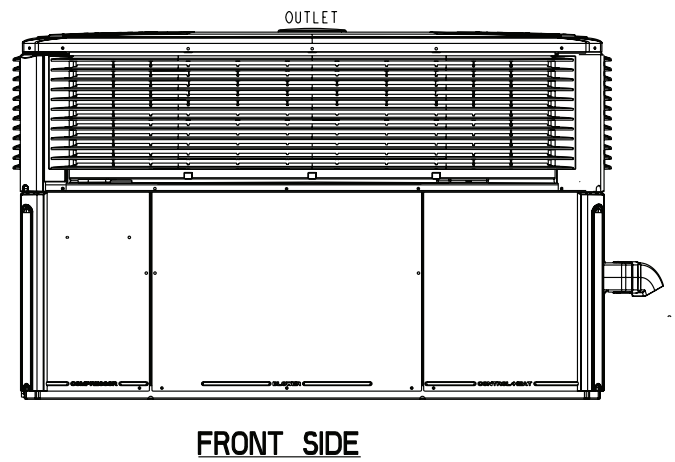

SECTION Y-Y
 TYPICAL (8) SIDES OF DOWNFLOW DUCT OPENINGS

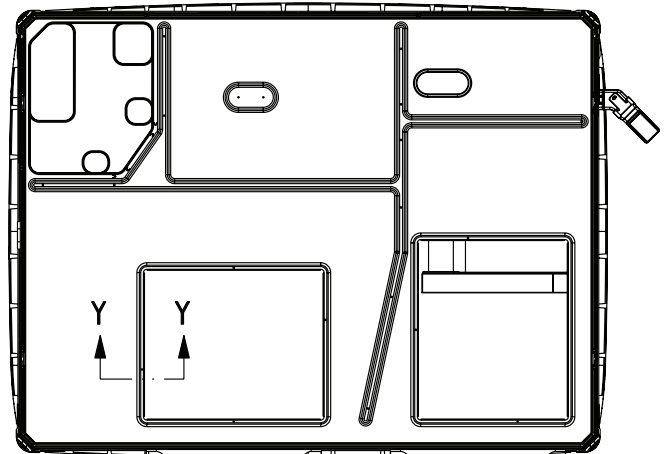

4DCY4042 through 4DCY4060 (1 of 3)

Dimensional Data

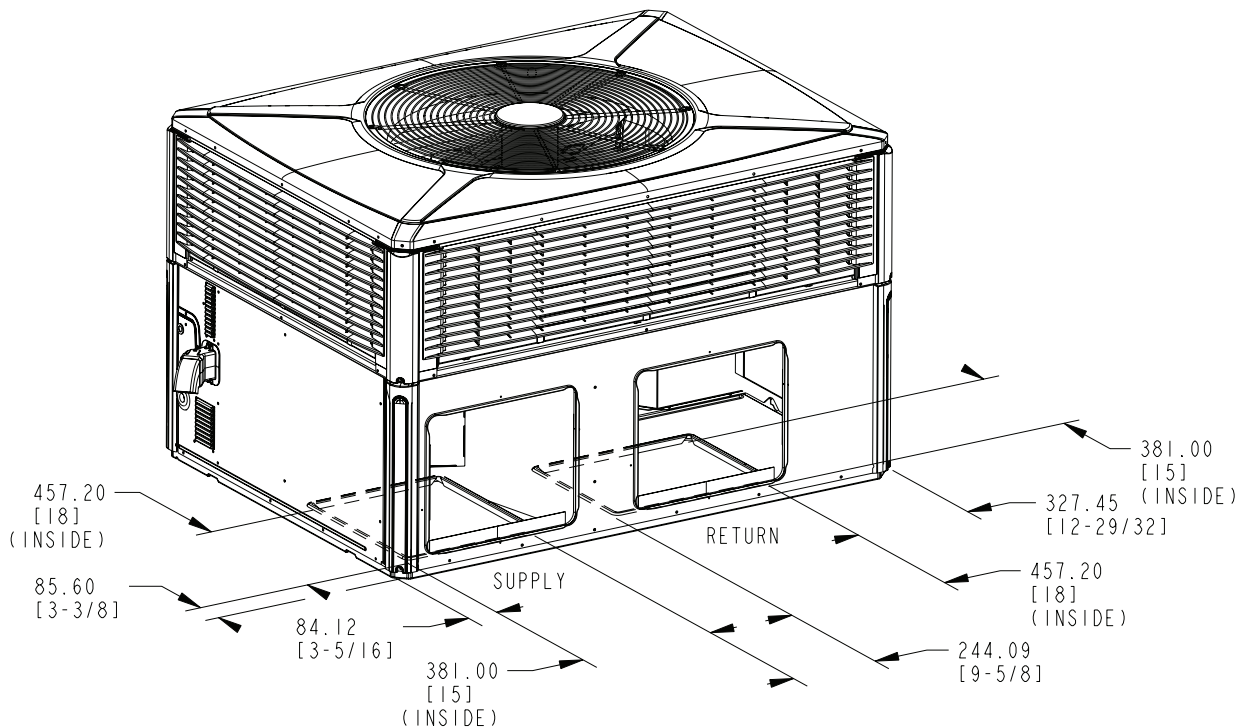

BOTTOM DUCT OPENINGS

RECOMMENDED SERVICE CLEARANCE MM/IN.		
		WITH O.A. DAMPER/ECON.
BACK SIDE	304.8 [12]	762.0 [30]
LEFT SIDE	914.4 [36]	1066.8 [42]
RIGHT SIDE	914.4 [36]	-
FRONT SIDE	1066.8 [42]	-

CLEARANCE TO COMBUSTIBLE MATERIAL MM/IN.	
BOTTOM	0
BACK SIDE	25.4 [1]
LEFT SIDE	152.4 [6]
RIGHT SIDE	304.8 [12]
FRONT SIDE	304.8 [12]
TOP	914.4 [36]

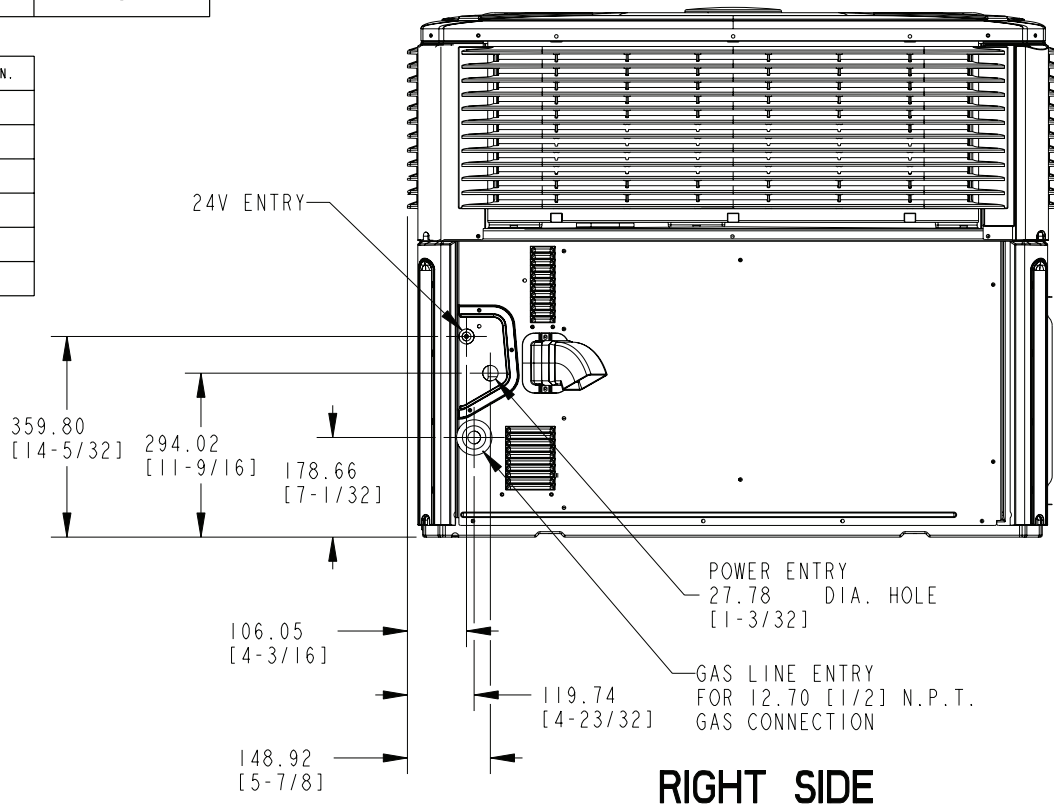

RIGHT SIDE

4DCY4042 through 4DCY4060 (2 of 3)

Dimensional Data

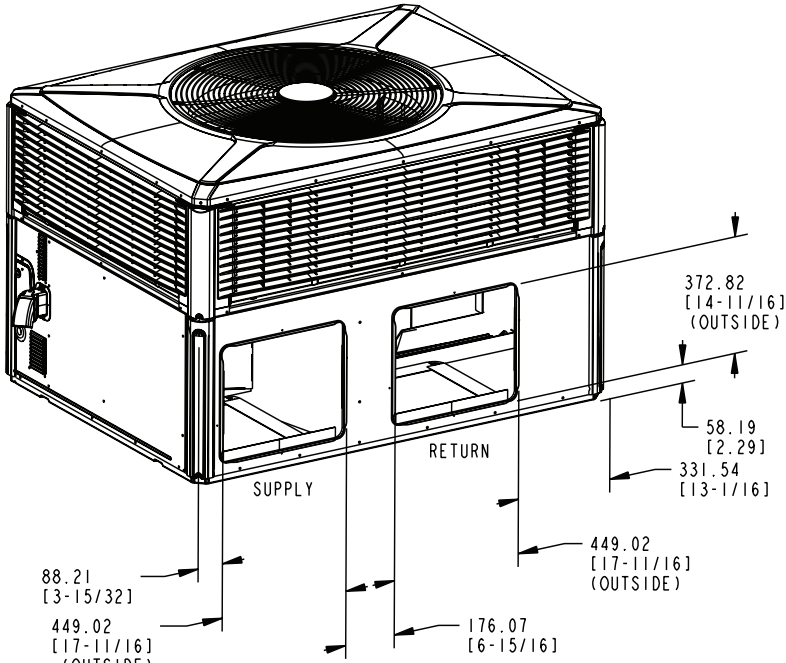

BACK DUCT OPENINGS

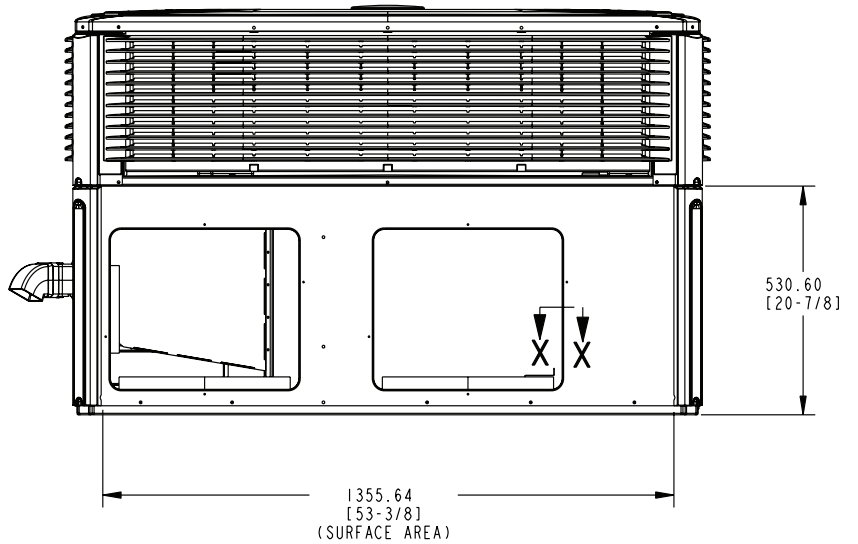
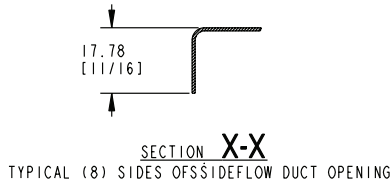

BACK SIDE

MODEL	HEIGHT MM/IN.	APPROX. CORNER WEIGHT - KG/LBS				SHIPPING WEIGHT KG/LBS	TOTAL UNIT WEIGHT KG/LBS	CENTER OF GRAVITY MM/IN.	
		A	W1	W2	W3			W4	B
4YCY4042/048A (096)	949.33 [37-3/8]	75.3 [166]	50.3 [111]	45.4 [100]	67.6 [149]	296.5 [653]	238.1 [525]	444.5 [17.5]	698.5 [27.5]
4YCY4048A (120)		75.7 [167]	50.8 [112]	45.8 [101]	68.5 [151]	299.2 [659]	240.9 [531]	444.5 [17.5]	698.5 [27.5]
4YCY4048B (096)		77.1 [170]	52.2 [115]	47.2 [104]	69.4 [153]	303.4 [669]	245.9 [541]	444.5 [17.5]	698.5 [27.5]
4YCY4048B (120)	949.33 [37-3/8]	77.1 [170]	52.2 [115]	47.2 [104]	69.4 [153]	303.4 [669]	245.9 [541]	444.5 [17.5]	698.5 [27.5]
4YCY4060A1/A3 (120)	1050.93 [41-3/8]	82.1 [181]	46.3 [102]	43.1 [95]	76.7 [169]	306.9 [676]	248.6 [548]	401.3 [15.8]	711.2 [28.0]
4DCY4042/048A (096)	949.33 [37-3/8]	77.1 [170]	51.3 [113]	45.4 [100]	67.6 [149]	296.5 [653]	238.4 [525]	442.0 [17.4]	698.5 [27.5]
4DCY4048B (096)	949.33 [37-3/8]	78.9 [174]	53.0 [117]	47.2 [104]	69.4 [153]	306.6 [676]	248.5 [548]	442.0 [17.4]	698.5 [27.5]
4DCY4060 (120)	1050.93 [41-3/8]	83.9 [185]	47.2 [104]	43.1 [95]	76.7 [169]	306.9 [676]	248.8 [548]	398.8 [15.7]	711.2 [28.0]
4YCZ6048A1/A3/A4 (096)	1050.93 [41-3/8]	75.7 [167]	50.8 [112]	45.8 [101]	68.5 [151]	299.2 [659]	240.9 [531]	444.5 [17.5]	698.5 [27.5]
4YCZ6048A1/A3/A4 (120)		81.6 [180]	46.3 [102]	42.2 [93]	73.5 [162]	301.6 [665]	243.6 [537]	419.1 [16.5]	706.1 [27.8]
4YCZ6060A1/A3/A4 (120)	1050.93 [41-3/8]	82.1 [181]	46.3 [102]	43.1 [95]	76.7 [169]	306.9 [676]	248.6 [548]	401.3 [15.8]	711.2 [28.0]
4DCZ6048 (096)	1050.93 [41-3/8]	81.6 [180]	46.3 [102]	42.2 [93]	73.5 [162]	301.6 [665]	243.6 [537]	419.1 [16.5]	706.1 [27.8]
4DCZ6060 (120)	1050.93 [41-3/8]	83.9 [185]	47.2 [104]	43.1 [95]	75.7 [169]	306.9 [676]	248.8 [548]	398.8 [15.7]	711.2 [28.0]

4DCY4042 through 4DCY4060 (3 of 3)

Mechanical Specifications

General

All units shall be factory assembled, piped, internally wired and fully charged with refrigerant. All units shall be designed to operate at outdoor ambient temperatures as high as 115°F. Cooling capacities shall be rated in accordance with A.H.R.I. standards. The 4DCY4 heating/cooling unit design is certified to UL Standards 1995 and ANSI 221.47/CSA 2.3, specifically for outdoor applications using natural gas or propane. All units shall be designed for outdoor rooftop or ground level installation. Unit casing is constructed of heavy gauge, galvanized steel and painted with a weather-resistant powder paint.

Shipped for horizontal application, convertible to downflow.

Casings

All panels shall be heavy gauge steel, gasketed and insulated. Foil-faced insulation shall be in the heat exchanger section. Foil-faced insulation shall be in the evaporator section. Base pan shall be heavy gauge steel. **WEATHERGUARD™** exterior corrosion resistant screws shall be used for added resistance to rust and corrosion.

Controls

Refrigeration cycle controls shall include condenser fan, evaporator fan and compressor contactors. Compressors shall be equipped with a combination internal winding thermostat/current overload. Internal high pressure relief shall also be provided.

Refrigeration System

Compressors —

The **Climatuff®** compressor features internal over temperature and pressure protector, total dipped hermetic motor. Other features include: centrifugal oil pump, and low vibration and noise.

Evaporator Coil — Internally enhanced 3/8-inch OD seamless copper tubing mechanically bonded to aluminum fins, factory pressure and leak tested at 250 to 300 psig. All units have TXV to control refrigeration flow.

Condenser Coil —

The **Spine Fin™** condenser coil shall be continuously wrapped, corrosion resistant all aluminum with minimum brazed joints. This coil is 3/8 inch OD seamless aluminum tubing glued to a continuous aluminum fin. Coils are lab tested to withstand 2,000 pounds of pressure per square inch. The outdoor coil provides low airflow resistance and efficient heat transfer. The coil is protected on all four sides by louvered panels.

Indoor Air Fan — Direct-drive, forward-curved, centrifugal wheel in a Composite **Vortica®** Blower housing. Motor shall have thermal overload protection. Permanently lubricated motor bearings. Motor/blower assembly isolated from unit with rubber mounts.

Condenser Fan — Direct-drive, draw through propeller type. Weather-proofed permanent split capacitor fan motor shall have built-in thermal overload and permanently lubricated motor bearings.

Low Ambient — Standard refrigerant system operation down to 55°F. Low ambient accessory required for operation to 0°F ambient condition.

Gas-Fired Heating System — Models shall provide completely assembled, wired and piped gas fired heating systems within unit. Threaded gas connection on the unit.

Electronic Ignition System — Main burner is lit each time thermostat calls for gas heat. Flame sensor proves flame and keeps the main burners on. Should a loss of flame occur, the main valve closes and the spark recurs within 0.8 second. When thermostat is satisfied, main burner is extinguished.

Forced Combustion Blower — Insures flame stability under varying wind conditions. Gives higher combustion efficiency and location flexibility.

Heat Exchanger — stainless steel tubes. Free floating design.

Burners — Stainless steel. Multi-port inshot.

Accessories

(U.S. Domestic Models)

Roof Curb — The roof curb shall be designed to mate with the unit and provide support and complete weather-tight installation when properly installed. Curb shall ship knocked down for field assembly, and include wood nailer strips.

Modulating Economizer — This accessory shall be field installed and be composed of the following items: 0-100% fresh air damper, damper drive motor fixed dry bulb enthalpy control, and low voltage polarized plug for electrical connections. Solid state enthalpy or differential enthalpy control is optional. Economizer operations shall be controlled by the preset position of the enthalpy control. A barometric relief damper shall be standard with the economizer and provide a pressure operated damper that shall be gravity closing and prohibit entrance of outside air on equipment "off" cycle.

Manual Fresh Air Hood

Manual outside air provides a fixed outside air quantity from 0 to 25 percent. Includes hood and birdscreen.

Low Ambient Control

Control allows cycling of compressor under low ambient cooling conditions. Required for cooling operation to 0°F.

Propane Gas

Conversion Kit — For conversion from natural gas to LP gas.

